



商品名 *

3本アームプーラー、特に強力なモデル

ベアリング、ギア、ディスク（盤）の引き抜き用。

商品番号 11-2-A

シリーズ 11-A

JANコード 4021176006203



技術属性	メートル	インペリアル
 スパン 外側	220 - 650 mm	8 5/8 - 25 5/8 inch
 クランプ深さ	200 mm	7 7/8 inch
 クランプ幅 内側	290 - 740 mm	11 3/8 - 29 1/8 inch
 外側六角	41 mm	
 max. 最大許容負荷	20 t	22 US t
 max. 最大トルク	650 Nm	479.5 ft lb
 重量	25 kg	
 下部の空間	20 mm	3/4 inch
 隣接する空間	67 mm	2 5/8 inch
 フックの数	3	3

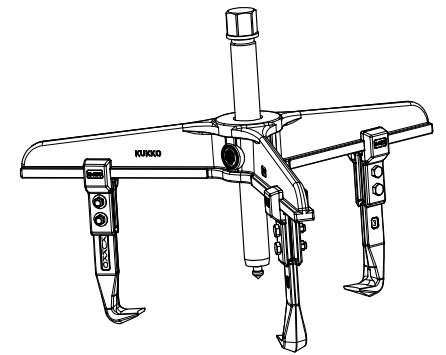
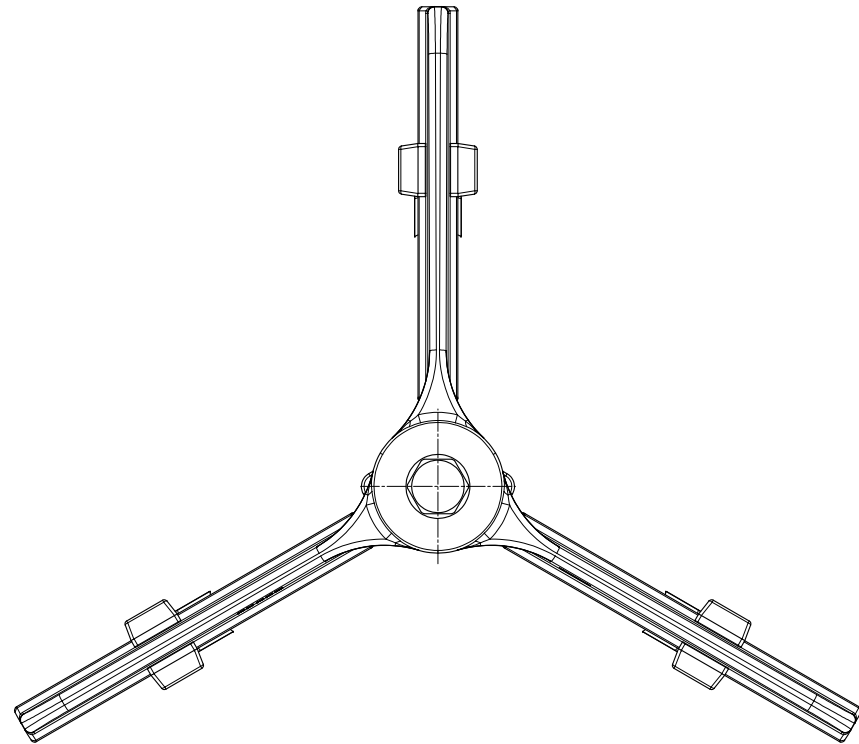
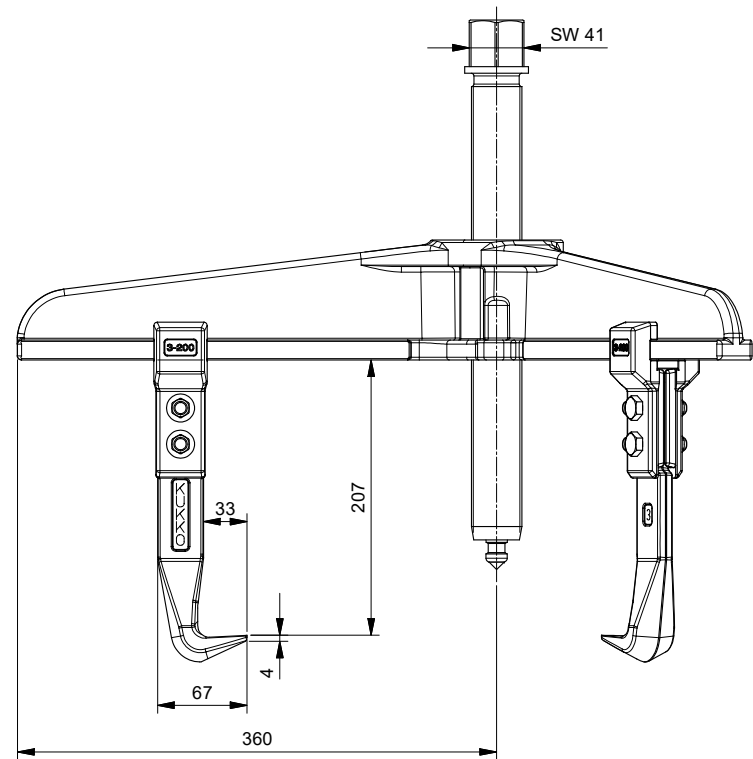
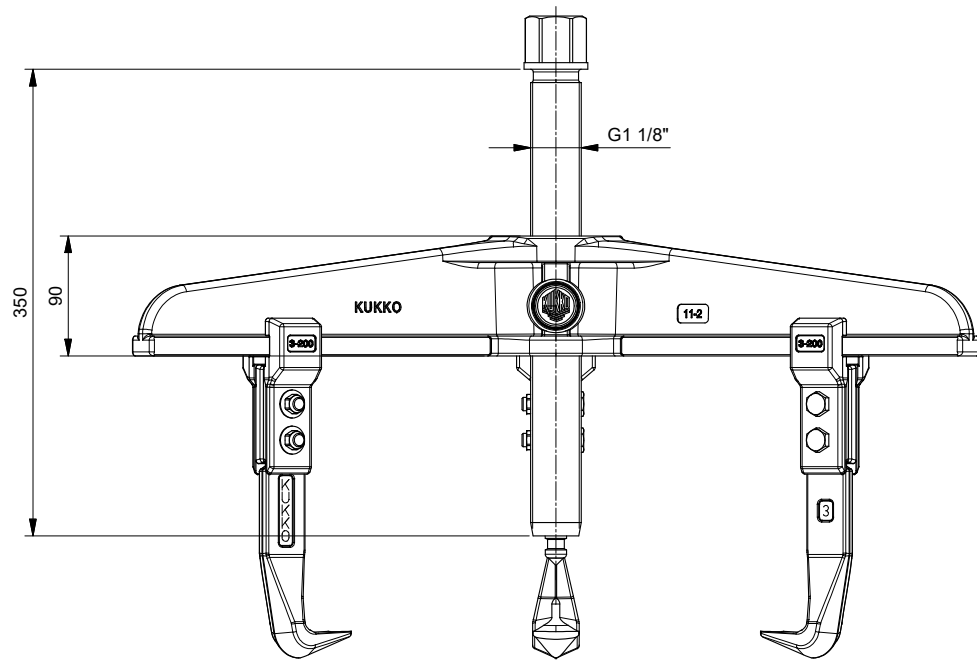

 Kleinbongartz & Kaiser oHG Werkzeugfabrik Hilden - Germany	Dokumentname: 11-2-A_3-armiger Abzieher	Teilname: DIN ISO 2768-m
	Dokumentbeschreibung: Baugruppe	Material: Hoch legierter Werkzeugstahl / High alloy tool steel
Erstellt von: Breidenbach	Erstellungsdatum: 17/01/2019	Maßstab: 1:2
Teilbeschreibung: 3-armiger Abzieher, extra kräftige Ausführung/ 3-jaw puller, high performance is guaranteed	Wärmebehandlung / Heat: vergüteter Stahl/ tempered steel	Oberflächenbehandlung: -
Artikelnummer / ZNR: 11-2-A	Dokumentversion: -	Schutzvermerk: ISO 16047 beachten