



Produktnavn

## 2-armet aftrækker til rulleleje, svensk model







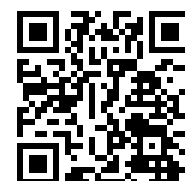

Til aftrækning af lejer, tandhjul, skiver etc.

Varenr. 112-10

Serie 112

EAN 4021176418891



	<b>Teknisk egenskab</b>	<b>Metrisk</b>	<b>Tomme</b>
	Spændvidde udvendig	10 - 65 mm	3/8 - 2 5/8 inch
	Spænddybde	70 mm	2 3/4 inch
	Udvendig sekskant	8 mm	
max.	Maksimal tilladt belastning	1,5 t	1.5 US t
	Maks. drejningsmoment	25 Nm	18 ft lb
	Vægt	0.46 kg	
	Rum nedenunder	5 mm	3/16 inch
	Rum ved siden af	12 mm	1/2 inch
	Antal kroge	2	2



## Teknologier



### SWITCH

Optimal spindeltilpasning til akslen gennem spindelspidser på to sider.



## Reservedel

Varenr.	Produktnavn
610110	Mekanisk trykspindel.
112-1-T	Travers
112-1-33	Spændering
112-10-70-P	2 aftrækningskroge (par) med spændestifter

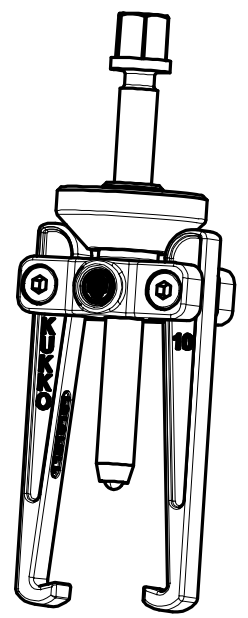
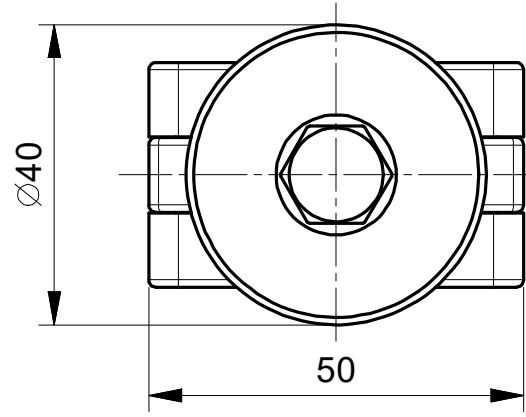
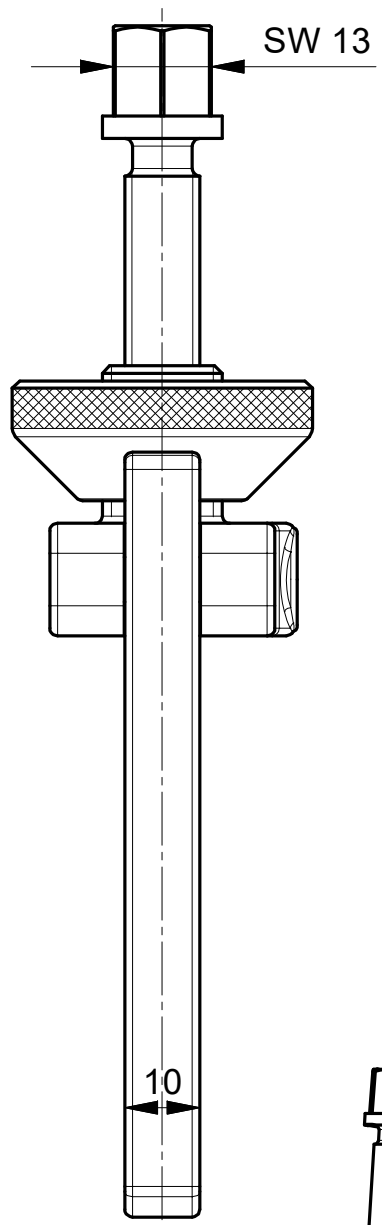
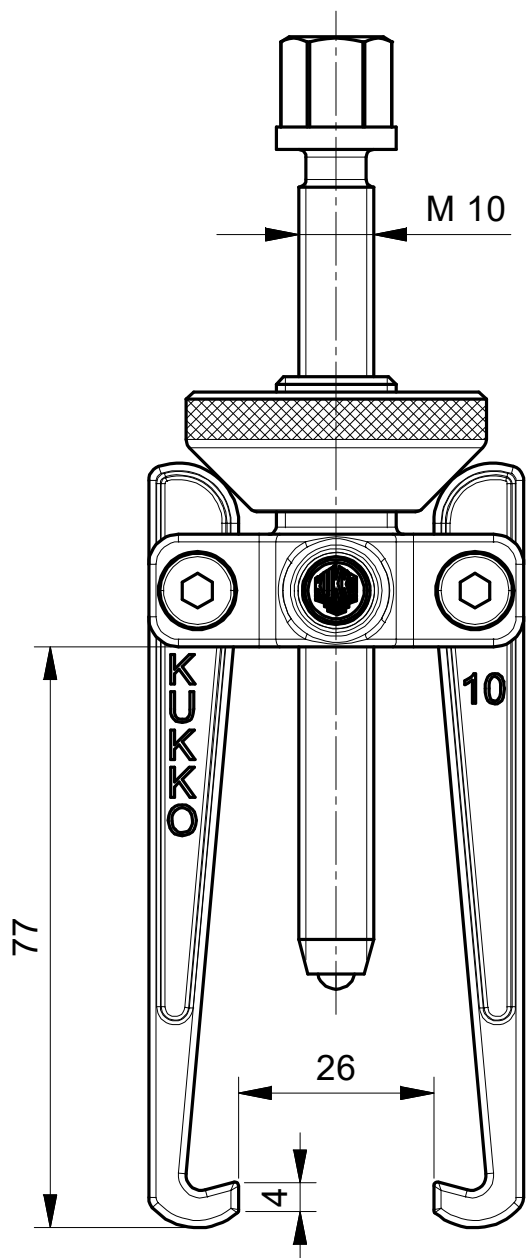

 <b>Kleinbongartz &amp; Kaiser oHG</b> <b>Werkzeugfabrik Hilden - Germany</b>	Dokumentname: 112-10_2-armiger Abzieher		Toleranz: DIN ISO 2768-m	
	Dokumentbeschreibung: Baugruppe		Material: Hoch legierter Werkzeugstahl / High alloy tool steel	
	Erstellt von: Breidenbach	Erstellungsdatum: 05/07/2018	Maßstab: 1:1	
Teilbeschreibung: 2-armiger Abzieher, schwedisches Modell/ 2-jaw puller, swedish model			Wärmebehandlung / Härte: vergüteter Stahl/ tempered steel	
			Oberflächenbehandlung:	
Artikelnummer / ZNR.: 112-10	Dokumentversion: -	Schutzvermerk ISO 16016 beachten		