



Nome do produto

Extrator de 2 braços para rolamentos, modelo sueco









Para remover rolamentos, engrenagens, discos, etc.

Artigo Nº 112-10

Série 112

EAN 4021176418891



	Características	Métrico	Polegada
	Extensão externa	10 - 65 mm	3/8 - 2 5/8 inch
	Profundidade de fixação	70 mm	2 3/4 inch
	Hexágono externo	8 mm	
max.	Carga máxima permitida	1,5 t	1.5 US t
	Binário máx.	25 Nm	18 ft lb
	Peso	0.46 kg	
	Quarto abaixo	5 mm	3/16 inch
	Quarto de drenagem secundária	12 mm	1/2 inch
	Número de ganchos	2	2



Tecnologias



SWITCH

Ajuste ótimo do fuso ao eixo graças à ponta do fuso de duas faces.



Peça de substituição

Artigo Nº	Nome do produto
610110	Eixo de compressão mecânico.
112-1-T	Travessa
112-1-33	Anel de aperto
112-10-70-P	2 ganchos de extração (par) com pinos de fixação

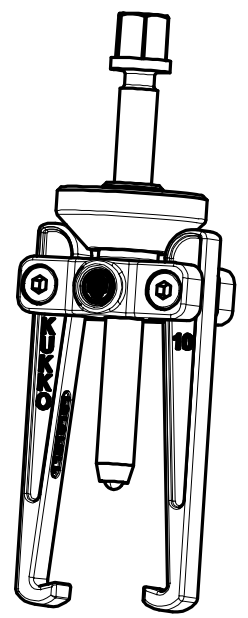
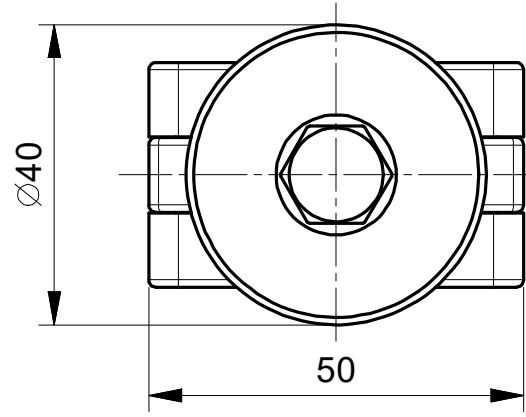
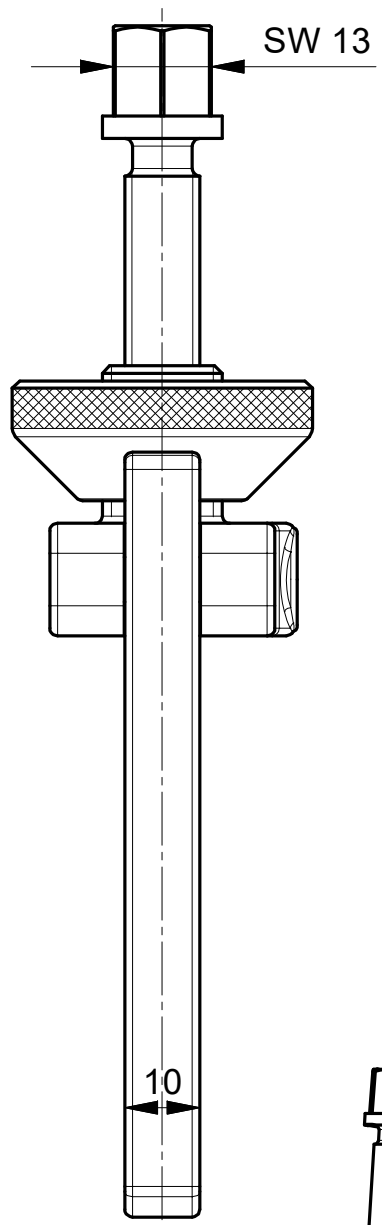
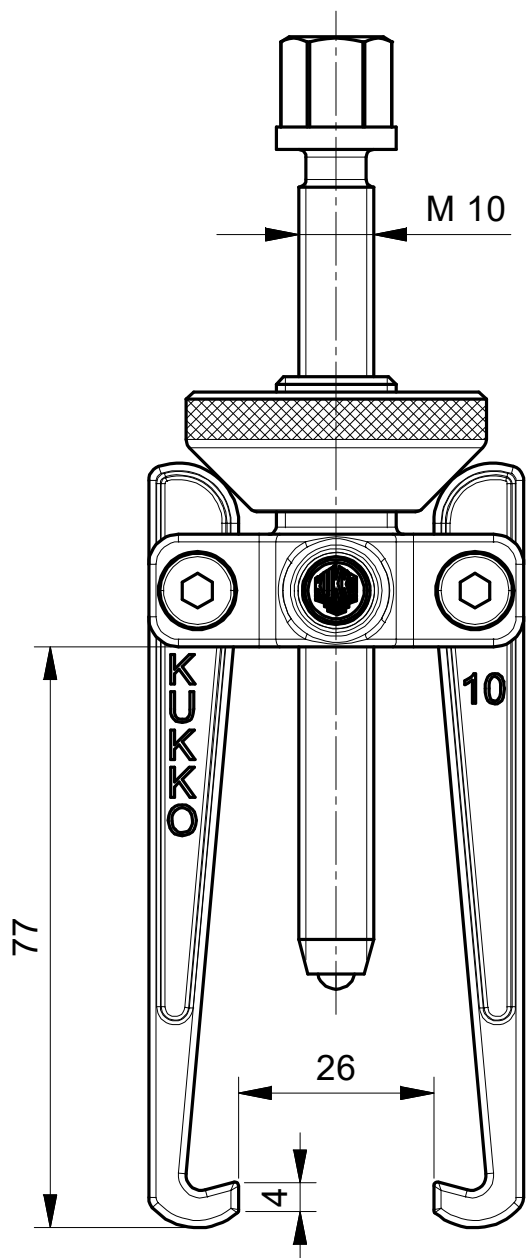

 <p>Kleinbongartz & Kaiser oHG Werkzeugfabrik Hilden - Germany</p>	Dokumentname: 112-10_2-armiger Abzieher		Toleranz: DIN ISO 2768-m	
	Dokumentbeschreibung: Baugruppe		Material: Hoch legierter Werkzeugstahl / High alloy tool steel	
	Erstellt von: Breidenbach	Erstellungsdatum: 05/07/2018	Maßstab: 1:1	
Teilbeschreibung: 2-armiger Abzieher, schwedisches Modell/ 2-jaw puller, swedish model			Wärmebehandlung / Härte: vergüteter Stahl/ tempered steel	
			Oberflächenbehandlung:	
Artikelnummer / ZNR.: 112-10	Dokumentversion: -		Schutzvermerk ISO 16016 beachten	