



Ürün adı

Rulmanlar için 2 kollu çekme aleti, İsveç tipi

Yatakları, dişlileri, rondelaları vb. çıkarmak için.

Ürün No. 112-1

Seriler 112









EAN 4021176418143



Teknik özellik

Metrik

Imparatorluk

	Teknik özellik	Metrik	Imparatorluk
	Açılma genişliği	10 - 55 mm	3/8 - 2 3/16 inch
	Derinlik	45 mm	1 3/4 inch
	Altıköşe geçme (erkek)	8 mm	
max.	İzin verilen maksimum yük	1,5 t	1.5 US t
	Maks. tork	25 Nm	18 ft lb
	Ağırlık	0.405 kg	
	Raum unterhalb	5 mm	3/16 inch
	Raum nebendran	12 mm	1/2 inch
	Çene sayısı	2	2



Teknolojiler



SWITCH

İki taraflı mil ucu sayesinde milin
şaftla optimum uyumu.



Yedek parça

Ürün No.	Ürün adı
610110	Mekanik mil
112-1-T	Gövde
112-1-45-P	Merkezleme pimlerine sahip 2 çektirme kolu (çift)
112-1-33	Segman halkası

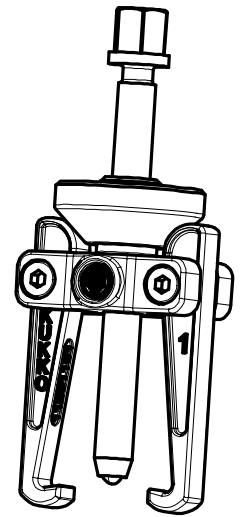
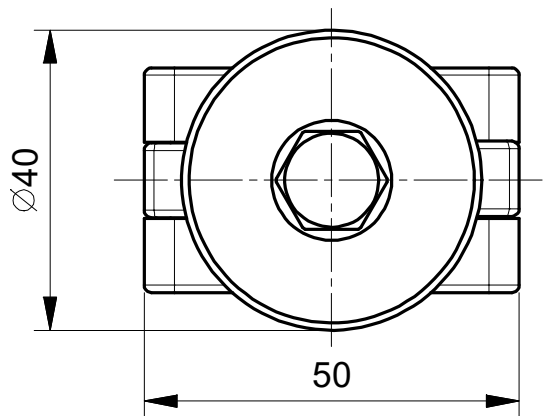
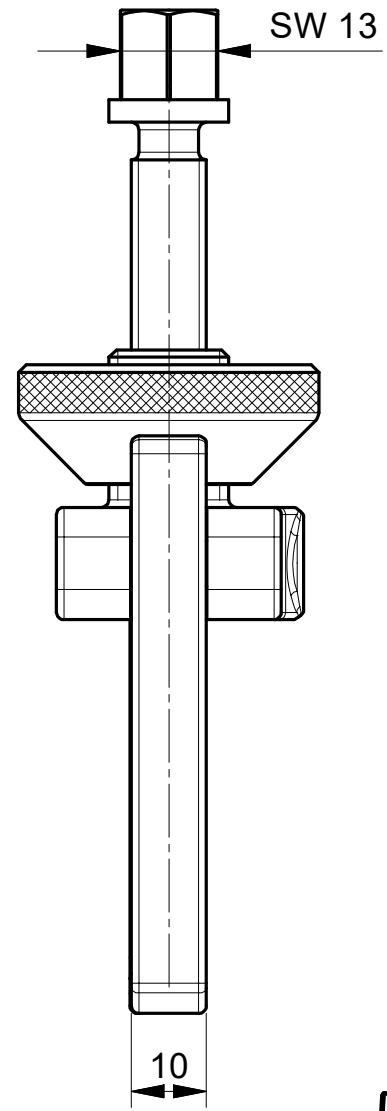
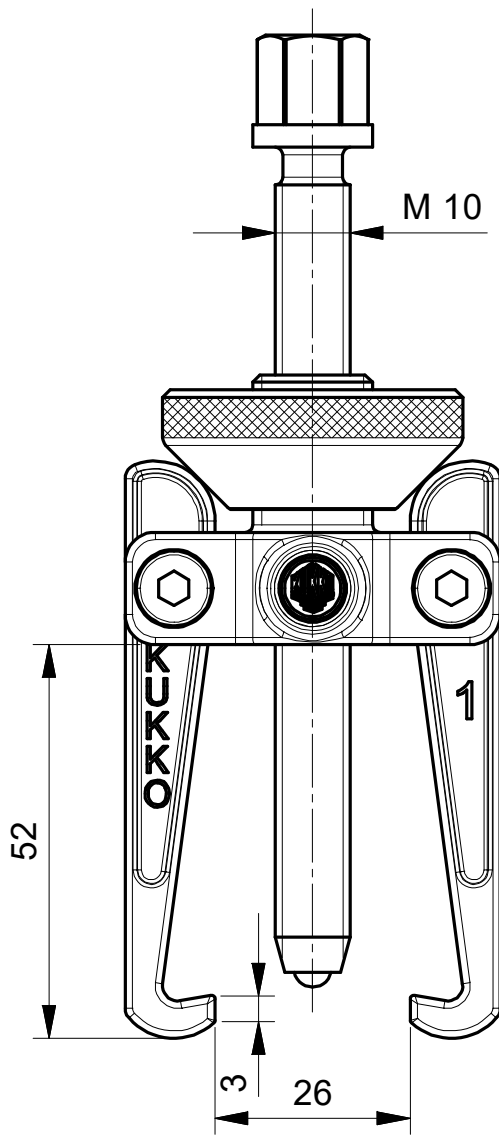

**Kleinbongartz
& Kaiser
oHG**
Werkzeugfabrik
Hilden - Germany

Dokumentname:
112-1_2-armiger Abzieher

Toleranz:
DIN ISO 2768-m

Dokumentbeschreibung:
Baugruppe

Material:
Hoch legierter Werkzeugstahl /
High alloy tool steel

Erstellt von:
Breidenbach

Erstellungsdatum:
05/07/2018

Maßstab:
1:1

Teilbeschreibung:
2-armiger Abzieher, schwedisches Modell/
2-jaw puller, swedish model

Wärmebehandlung / Härte:
vergüteter Stahl/ tempered steel

Oberflächenbehandlung:

Artikelnummer / ZNR.:
112-1

Dokumentversion:
-

Schutzvermerk
ISO 16016
beachten