



Produktnavn

3-armet aftrækker "Alligator" med forindstillelige aftrækningskroge









Til aftrækning af lejer, tandhjul, skiver etc.

Varenr. 12-1

Serie 12

EAN 4021176006616



	Teknisk egenskab	Metrisk	Tomme
	Spændvidde udvendig	20 - 100 mm	3/4 - 3 7/8 inch
	Spænddybde	100 mm	3 7/8 inch
	Udvendig sekskant	17 mm	
max.	Maksimal tilladt belastning	8 t	8.5 US t
	Maks. drejningsmoment	180 Nm	132.5 ft lb
	Vægt	1.24 kg	
	Rum nedenunder	17 mm	5/8 inch
	Rum ved siden af	25 mm	1 inch
	Antal kroge	3	3



Teknologier



SELFLOCK

Den centrale, faste spænding af aftrækkerkroge ved hjælp af låseskruen forhindrer, at kroge bevæger sig eller glider.



SWITCH

Optimal spindeltilpasning til akslen gennem spindelspidser på to sider.



Reservedel

Varenr.	Produkt navn
12-1-T	Travers
12-1-100-S	3 aftrækningskroge (sæt)
12-1-206	Traversinderbøsning med spindel
12-1-8	Nøgle
614135	Mekanisk trykspindel.

Tilbehør

Varenr.	Produkt navn
K-600-014	Sæt med udskiftelige trykstykker til KUKKO-trykspindler

Er bestanddel af

Varenr.	Produkt navn
EVLW-2-INDUSTRIE	Salgsvæg industri

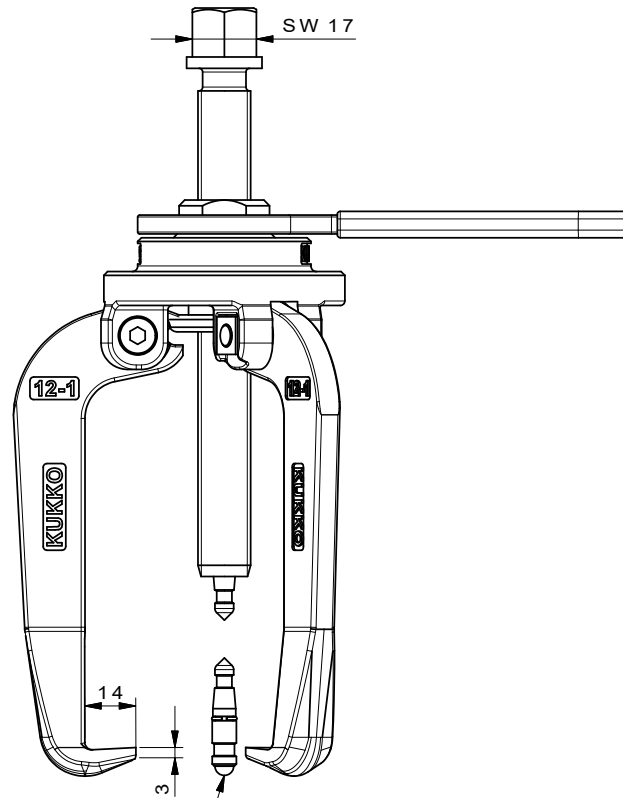
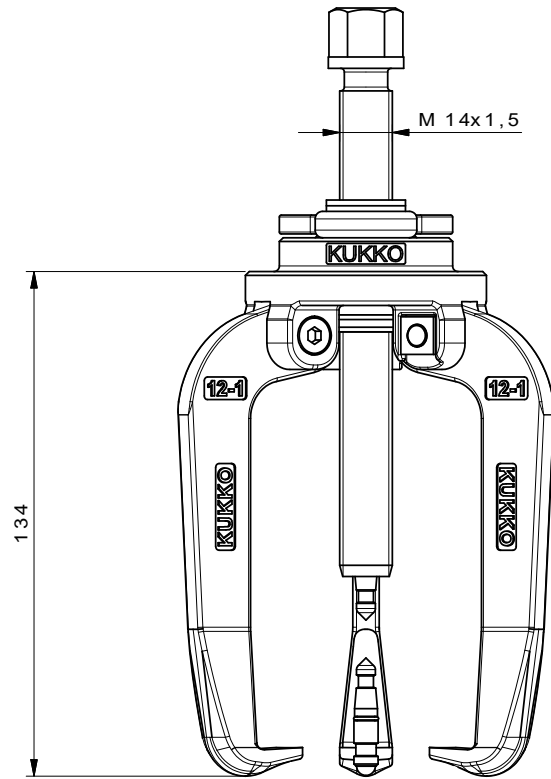

Drehbares Wechseldruckstück
mit Kugel und Spitze

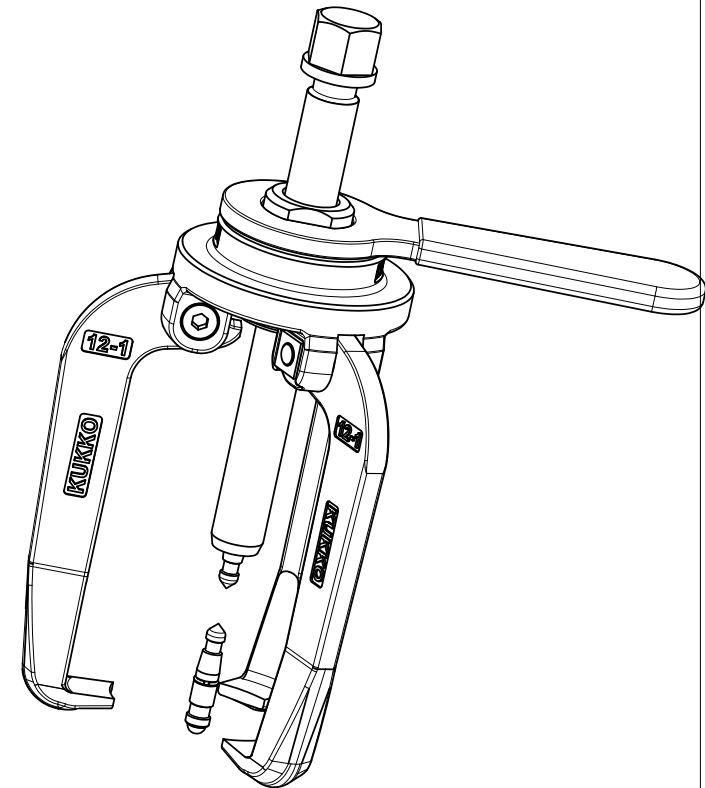
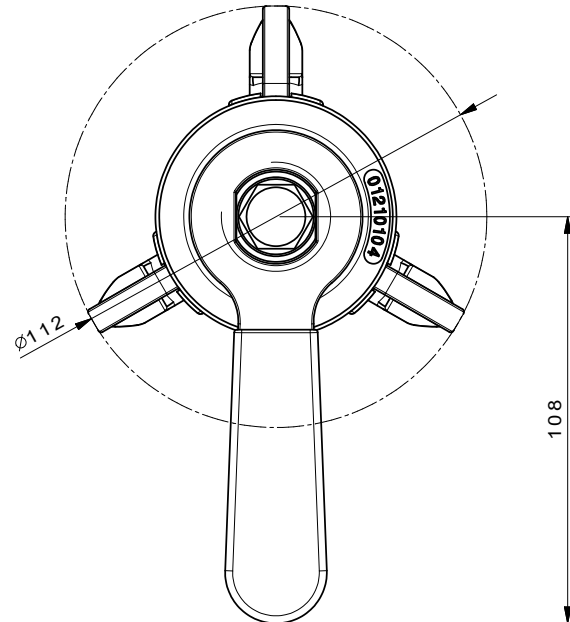

 Kleinbongartz & Kaiser oHG Werkzeugfabrik Hilden - Germany	Dokumentname: 12-1_3-armiger Abzieher-Alligator	Toleranz: DIN ISO 2768-m
	Dokumentbeschreibung: Baugruppe	Material: Hoch legierter Werkzeugstahl / High alloy tool steel
Erstellt von: Schultes	Erstellungsdatum: 07/04/2016	Maßstab: 1:1
Teilbeschreibung: 12-1_3-armiger Abzieher-Alligator/ 3-jaw "alligator" puller with pre-settable jaws		Wärmebehandlung / Härte: vergüteter Stahl/ tempered steel
		Oberflächenbehandlung:
Artikelnummer / ZNR.: 12-1_3	Dokumentversion: -	Schutzvermerk ISO 16616 beachten