



Nombre del producto

Extractor de 3 brazos «Alligator» con ganchos de extracción preajustables

Para extraer rodamientos, ruedas dentadas, discos,
etc.

Núm. art. 12-1

Serie 12

EAN 4021176006616

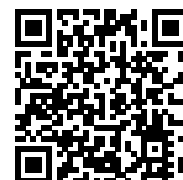

	Atributo técnico	Métrico	Imperial
	Envergadura de sujeción exterior	20 - 100 mm	3/4 - 3 7/8 inch
	Profundidad de sujeción	100 mm	3 7/8 inch
	Hexágono exterior	17 mm	
max.	Carga máxima admisible	8 t	8.5 US t
	Momento de giro máximo	180 Nm	132.5 ft lb
	Peso	1.24 kg	
	Espacio debajo	17 mm	5/8 inch
	Espacio adyacente	25 mm	1 inch
	Cantidad de ganchos	3	3



Tecnologías



SELFLOCK

El tensado céntrico y firme de los ganchos de tracción mediante un tornillo de bloqueo impide que los ganchos se muevan o resbalen.



SWITCH

Adaptación óptima del husillo al eje gracias a la punta del husillo de dos lados.



Pieza de recambio

Núm. art.	Nombre del producto
12-1-T	Travesaño
12-1-100-S	3 Garras de extracción (Juego)
12-1-206	Casquillo interior del travesaño con husillo
12-1-8	Llaves
614135	Husillo mecánico.

Accesorios

Núm. art.	Nombre del producto
K-600-014	Juego de pieza de presión alterna para husillos de presión

Es parte de

Núm. art.	Nombre del producto
EVLW-2-INDUSTRIE	Expositor de venta, herramientas para industria

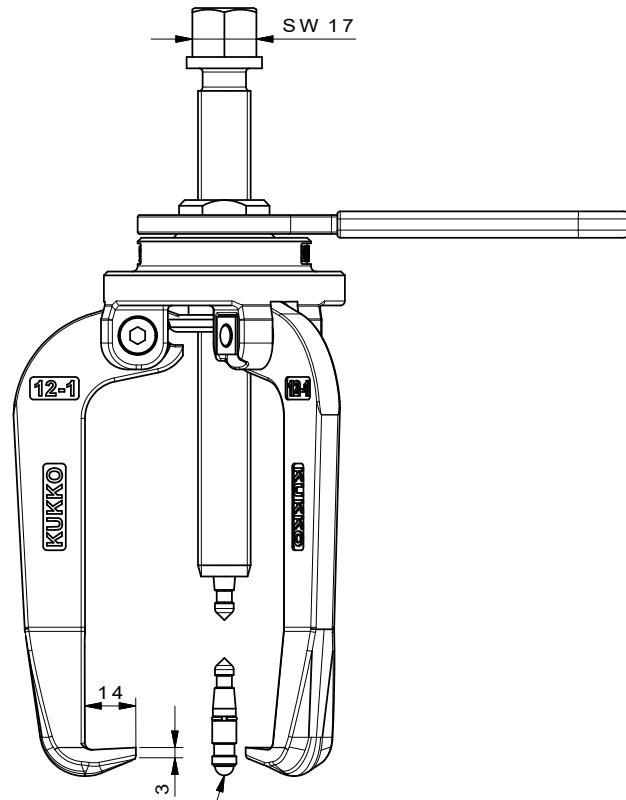
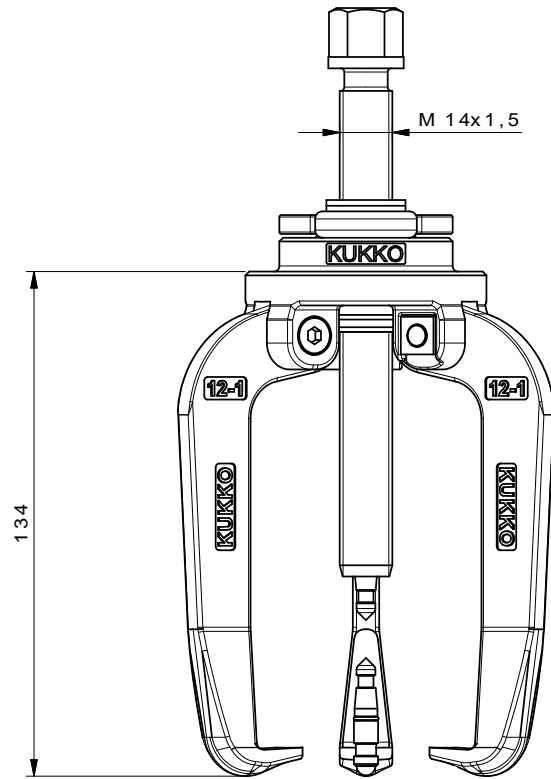

Drehbares Wechseldruckstück
mit Kugel und Spitze

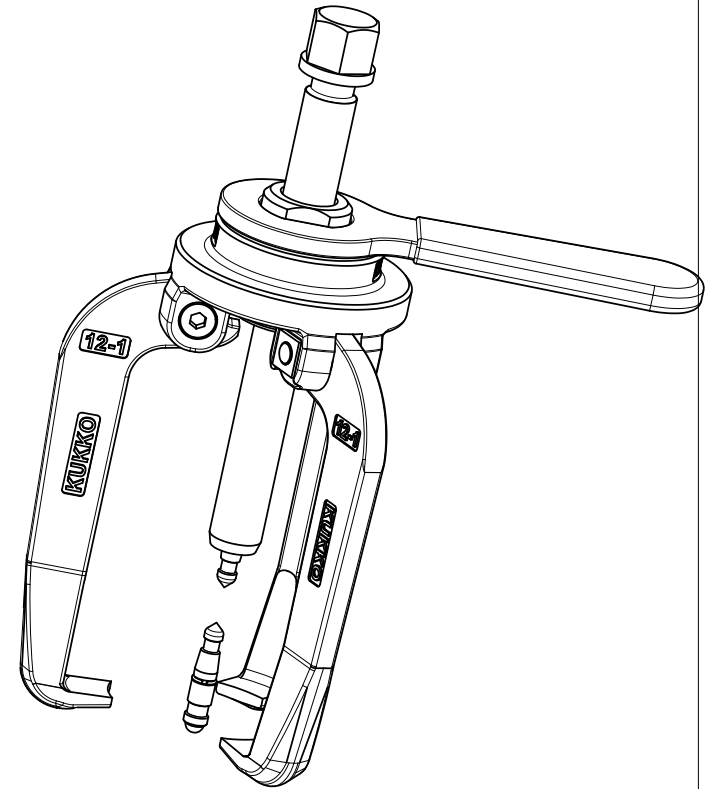
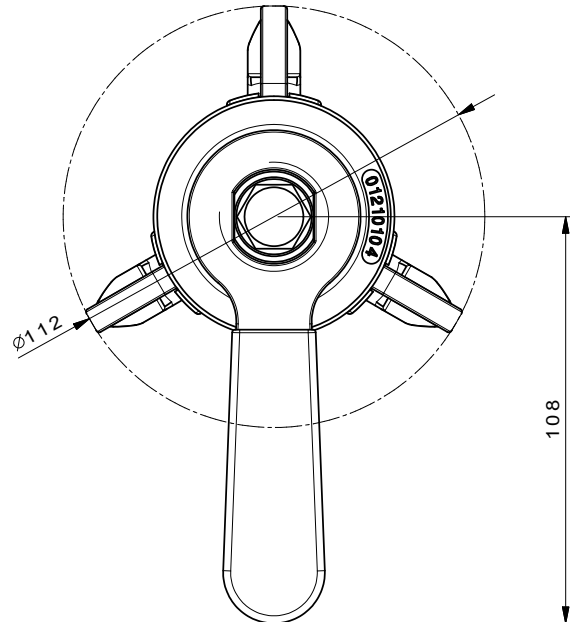

 Kleinbongartz & Kaiser oHG Werkzeugfabrik Hilden - Germany	Dokumentname: 12-1_3-armiger Abzieher-Alligator	Toleranz: DIN ISO 2768-m
	Dokumentbeschreibung: Baugruppe	Material: Hoch legierter Werkzeugstahl / High alloy tool steel
Erstellt von: Schultes	Erstellungsdatum: 07/04/2016	Maßstab: 1:1
Teilbeschreibung: 12-1_3-armiger Abzieher-Alligator/ 3-jaw "alligator" puller with pre-settable jaws		Wärmebehandlung / Härte: vergüteter Stahl/ tempered steel
Artikelnummer / ZNR.: 12-1_3		Oberflächenbehandlung: Schutzvermerk ISO 16616 beachten