



Nome del prodotto

Estrattore a 3 bracci "Alligator" con griffe preregolabili









Per l'estrazione di cuscinetti, ingranaggi, pulegge ecc.

Num. art. 12-1

Serie 12

EAN 4021176006616



	Attributo tecnico	Metrico	Imperiale
	Ampiezza di serraggio esterna	20 - 100 mm	3/4 - 3 7/8 inch
	Profondità di serraggio	100 mm	3 7/8 inch
	Esagono esterno	17 mm	
max.	Carico massimo consentito	8 t	8.5 US t
	Coppia massima	180 Nm	132.5 ft lb
	Peso	1.24 kg	
	Spazio sotto	17 mm	5/8 inch
	Spazio adiacente	25 mm	1 inch
	Numero delle griffe	3	3



Tecnologie



SELFLOCK

Il serraggio robusto e concentrico dei ganci di estrazione mediante vite di arresto impedisce che i ganci si muovano o scivolino.



SWITCH

Adattamento ottimale dei mandrini all'albero grazie alla punta bilaterale dei mandrini.



Pezzo di ricambio

Num. art.	Nome del prodotto
12-1-T	Traversa
12-1-100-S	3 griffe (set)
12-1-206	Traversa con boccola e vite di pressione
12-1-8	Chiave
614135	Vite di pressione meccanica.

Acessori

Num. art.	Nome del prodotto
K-600-014	Set di pressori intercambiabili per viti di pressione KUKKO

é parte di

Num. art.	Nome del prodotto
EVLW-2-INDUSTRIE	Display di vendita Industria

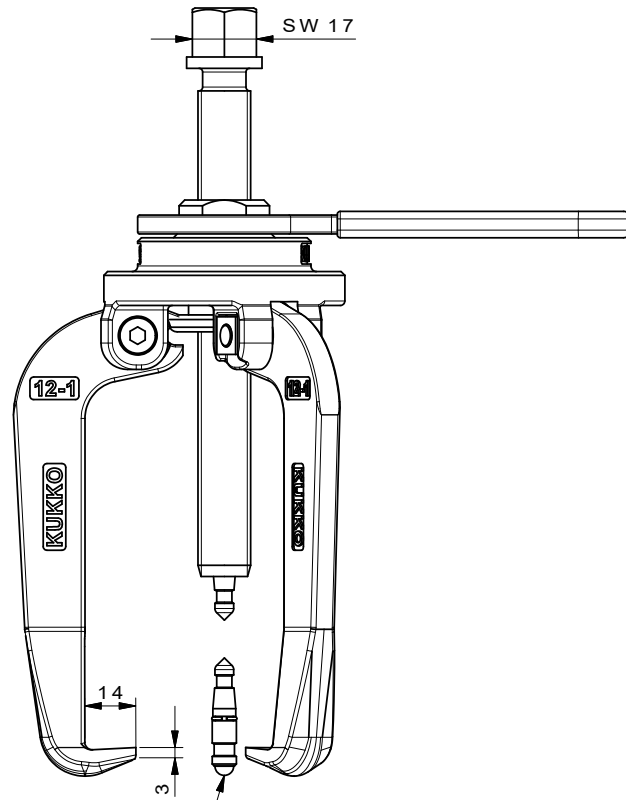
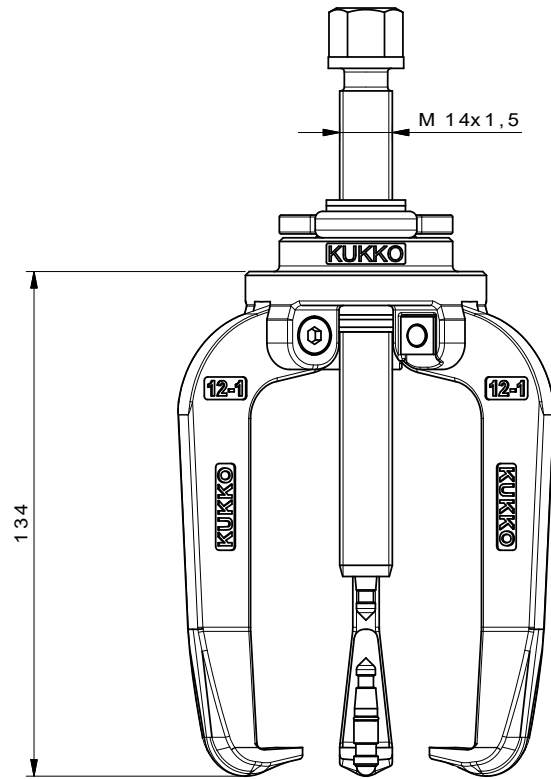

Drehbares Wechseldruckstück
mit Kugel und Spitze

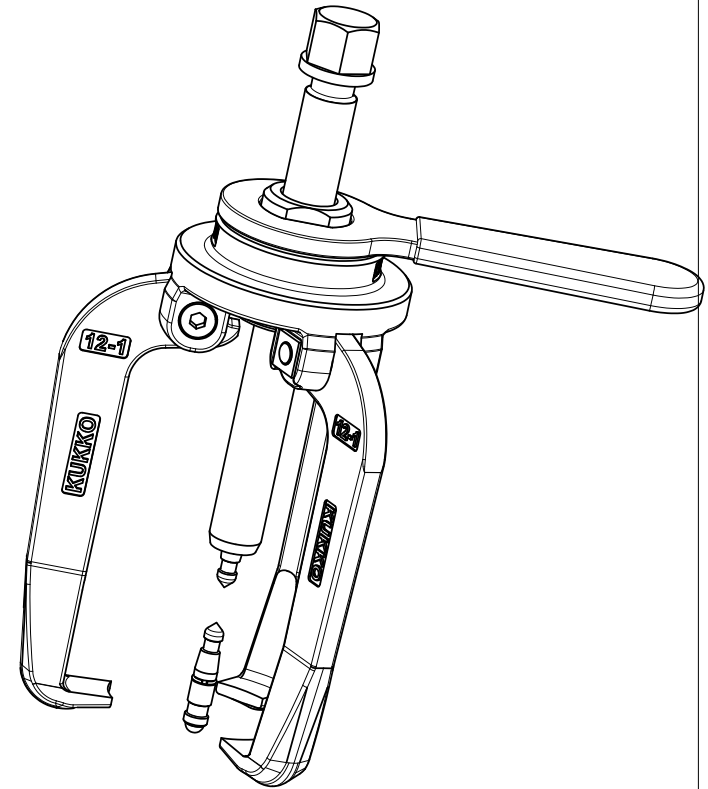
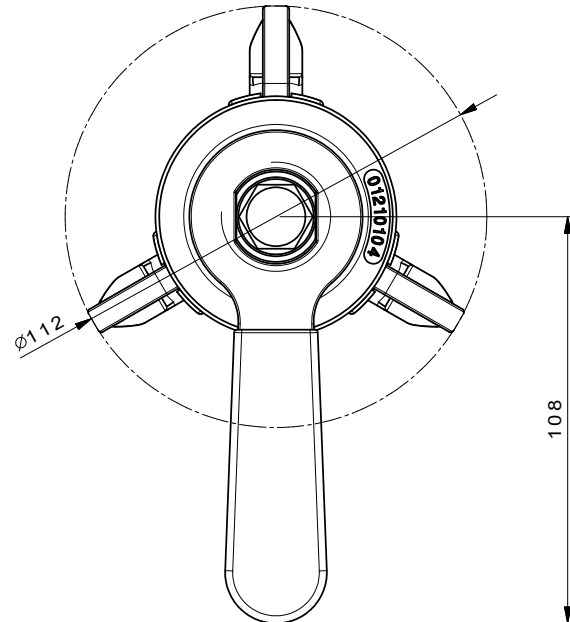

 Kleinbongartz & Kaiser oHG Werkzeugfabrik Hilden - Germany	Dokumentname: 12-1_3-armiger Abzieher-Alligator	Toleranz: DIN ISO 2768-m
	Dokumentbeschreibung: Baugruppe	Material: Hoch legierter Werkzeugstahl / High alloy tool steel
Erstellt von: Schultes	Erstellungsdatum: 07/04/2016	Maßstab: 1:1
Teilbeschreibung: 12-1_3-armiger Abzieher-Alligator/ 3-jaw "alligator" puller with pre-settable jaws		Wärmebehandlung / Härte: vergüteter Stahl/ tempered steel
Artikelnummer / ZNR.: 12-1_3		Oberflächenbehandlung: Schutzvermerk ISO 16616 beachten