



Productnaam

3-armige trekker "Alligator" met vooraf instelbare trekhaken









Voor het trekken van lagers, tandwielen, schijven enz

Art nr. 12-1

Serie 12

EAN 4021176006616



	Technisch kenmerk	Metrisch	Imperial
	Spanwijdte, uitwendig	20 - 100 mm	3/4 - 3 7/8 inch
	Spandiepte	100 mm	3 7/8 inch
	Buitenzeskant	17 mm	
max.	Maximaal toegestane belasting	8 t	8.5 US t
	Max. aandraaimoment	180 Nm	132.5 ft lb
	Gewicht	1.24 kg	
	Ruimte beneden	17 mm	5/8 inch
	Raum nebendran	25 mm	1 inch
	Aantal haken	3	3



Technologieën



SELFLOCK

De trekhaken worden via een stelschroef gecentreerd en vast aangetrokken zodat ze niet bewegen of afschuiven.



SWITCH

Optimale aanpassing van de spil aan de as dankzij de dubbele spilkop.



Onderdeel

Art nr.	Productnaam
12-1-T	Brug
12-1-100-S	3 trekhaken (set)
12-1-206	Draadbus voor brug met spindel
12-1-8	Sleutel
614135	Mechanische spindels.

Toebehoren

Art nr.	Productnaam
K-600-014	Wisseldrukstukken set voor KUKKO spindels

Is onderdeel van

Art nr.	Productnaam
EVLW-2-INDUSTRIE	Verkoopwand, industrie-gereedschap

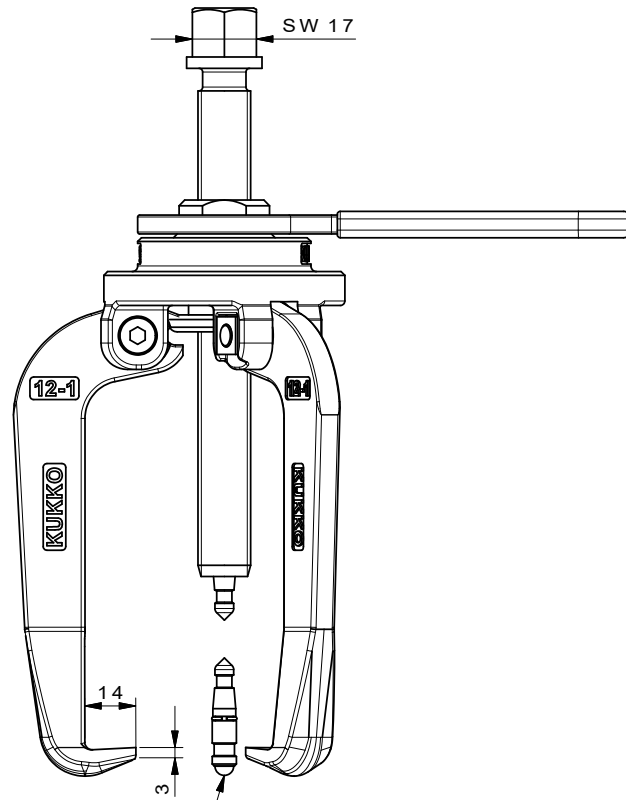
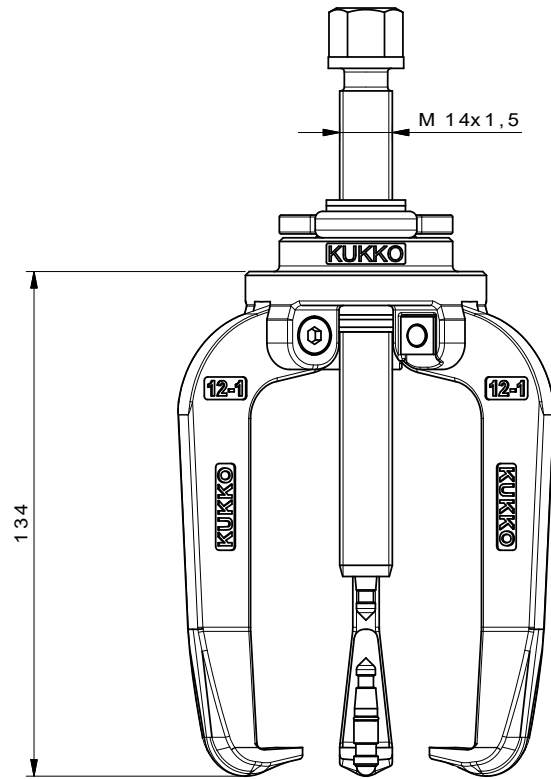

Drehbares Wechseldruckstück
mit Kugel und Spitze

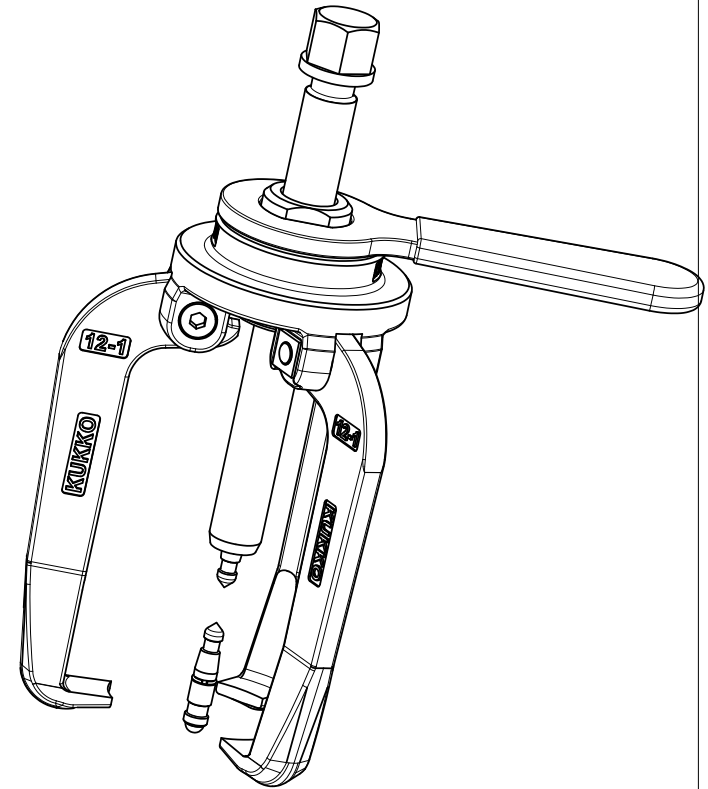
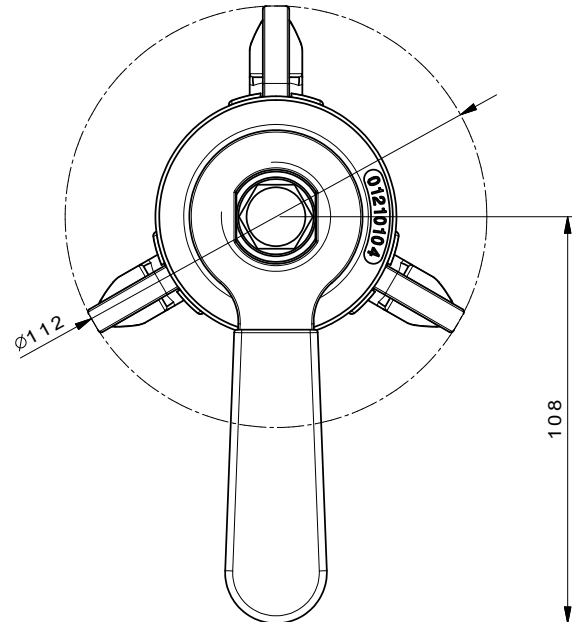

 Kleinbongartz & Kaiser oHG Werkzeugfabrik Hilden - Germany	Dokumentname: 12-1_3-armiger Abzieher-Alligator	Toleranz: DIN ISO 2768-m
	Dokumentbeschreibung: Baugruppe	Material: Hoch legierter Werkzeugstahl / High alloy tool steel
Erstellt von: Schultes	Erstellungsdatum: 07/04/2016	Maßstab: 1:1
Teilbeschreibung: 12-1_3-armiger Abzieher-Alligator/ 3-jaw "alligator" puller with pre-settable jaws		Wärmebehandlung / Härte: vergüteter Stahl/ tempered steel
		Oberflächenbehandlung:
Artikelnummer / ZNR.: 12-1_3	Dokumentversion: -	Schutzvermerk ISO 16616 beachten