



Nombre del producto

## Extractor universal de 2 brazos "Economy"







Para extraer rodamientos, ruedas dentadas, discos,  
etc.

Núm. art. 120-10

Serie 120

EAN 4021176918599



	Atributo técnico	Métrico	Imperial
	Envergadura de sujeción exterior	50 - 125 mm	2 - 4 7/8 inch
	Profundidad de sujeción	100 mm	3 7/8 inch
	Hexágono exterior	17 mm	
max.	Carga máxima admisible	3 t	3,30 US t
	Peso	1.16 kg	
	Espacio debajo	9 mm	3/8 inch
	Espacio adyacente	32 mm	1 1/4 inch
	Cantidad de ganchos	2	2



## Tecnologías



### **PUSH TO UNLOCK**

Sistema de liberación para una rápida fijación y fácil desbloqueo.



### **SWITCH**

Adaptación óptima del husillo al eje gracias a la punta del husillo de dos lados.



## Pieza de recambio

<b>Núm. art.</b>	<b>Nombre del producto</b>
614135	Husillo mecánico.
0-100-P	2 ganchos de extracción (par)
120-10-T	Travesaño

## Accesorios

<b>Núm. art.</b>	<b>Nombre del producto</b>
K-600-014	Juego de pieza de presión alterna para husillos de presión

## Es parte de

<b>Núm. art.</b>	<b>Nombre del producto</b>
120-ST	Caballote de exhibición "Economy"



## Es pieza de sustitucion de

**Núm. art.**

**Nombre del producto**

120-ST

Caballete de exhibición "Economy"

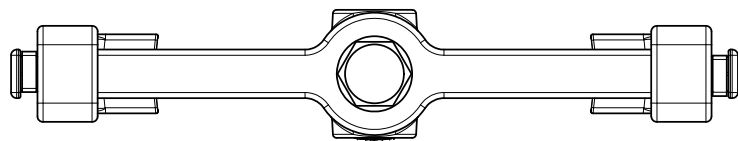
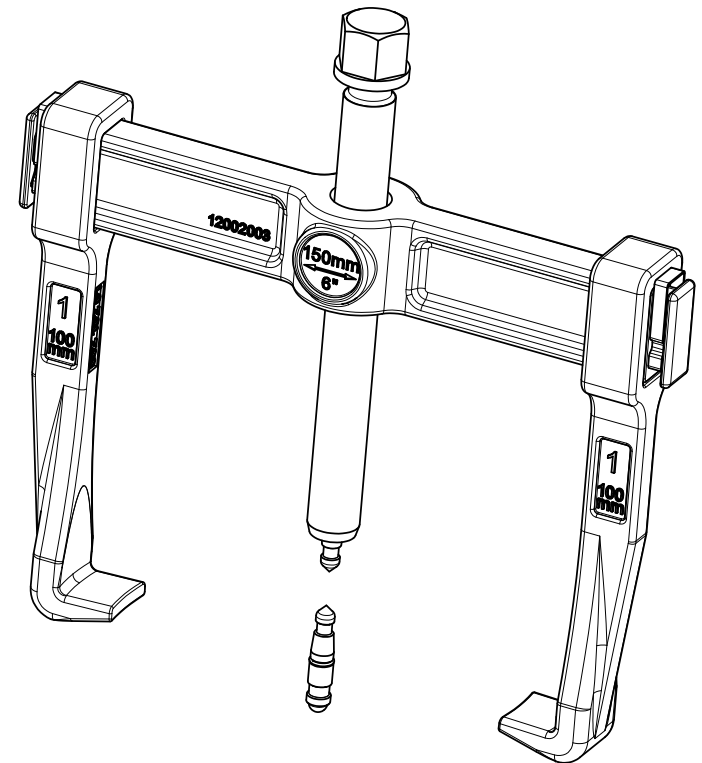
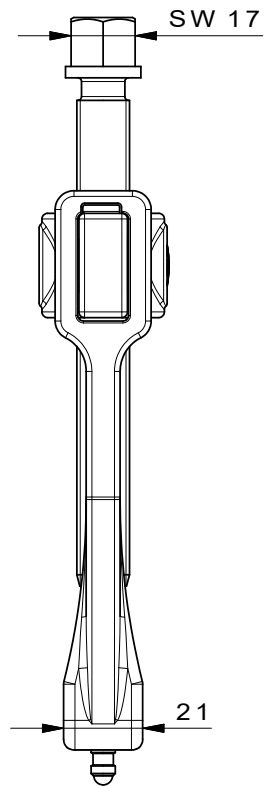
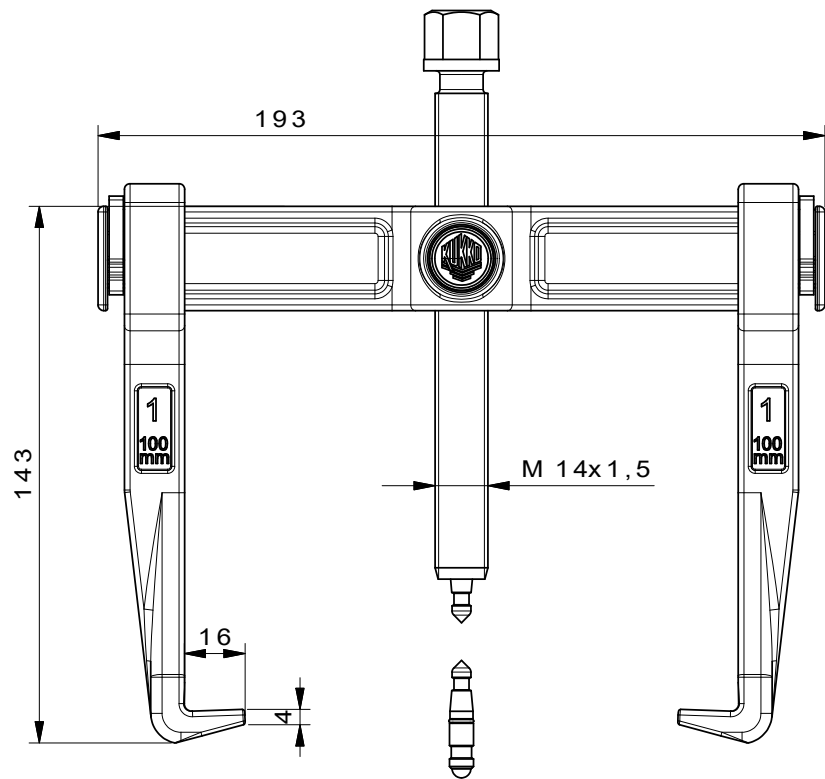

	<b>Kleinbongartz &amp; Kaiser oHG</b> Werkzeugfabrik Hilden - Germany		Dokumentname: 120-10_2-armiger Universalabzieher-Vario	Toleranz: DIN ISO 2768-m
	Dokumentbeschreibung: Baugruppe		Material: Hoch legierter Werkzeugstahl / High alloy tool steel	Maßstab: 1:1
Teilbeschreibung: 2-armiger Universalabzieher-Vario/ Universal 2-jaw puller "Vario"		Erstellt von: Schultes	Erstellungsdatum: 11/04/2016	Wärmebehandlung / Härte: vergüteter Stahl/ tempered steel
Artikelnummer / ZNR.: 120-10		Dokumentversion: -	Oberflächenbehandlung: -	
Schutzvermerk ISO 16616 beachten				