



Nome del prodotto

Estrattore universale a 2 bracci "Economy"







Per l'estrazione di cuscinetti, ingranaggi, pulegge ecc.

Num. art. 120-10

Serie 120

EAN 4021176918599



	Attributo tecnico	Metrico	Imperiale
	Ampiezza di serraggio esterna	50 - 125 mm	2 - 4 7/8 inch
	Profondità di serraggio	100 mm	3 7/8 inch
	Esagono esterno	17 mm	
max.	Carico massimo consentito	3 t	3,30 US t
	Peso	1.16 kg	
	Spazio sotto	9 mm	3/8 inch
	Spazio adiacente	32 mm	1 1/4 inch
	Numero delle griffe	2	2



Tecnologie



PUSH TO UNLOCK

Sistema di sbloccaggio per il fissaggio sicuro e una semplice rimozione del blocco di ritenuta.



SWITCH

Adattamento ottimale dei mandrini all'albero grazie alla punta bilaterale dei mandrini.



Pezzo di ricambio

Num. art.	Nome del prodotto
614135	Vite di pressione meccanica.
0-100-P	2 griffe (paio)
120-10-T	Traversa

Acessori

Num. art.	Nome del prodotto
K-600-014	Set di pressori intercambiabili per viti di pressione KUKKO

é parte di

Num. art.	Nome del prodotto
120-ST	Display di vendita "Economy"



é pezzo di ricambio di

Num. art.

Nome del prodotto

120-ST

Display di vendita "Economy"

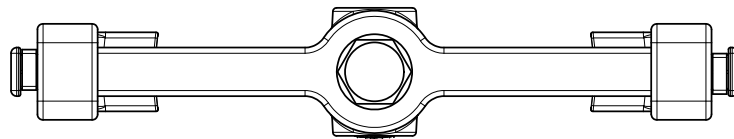
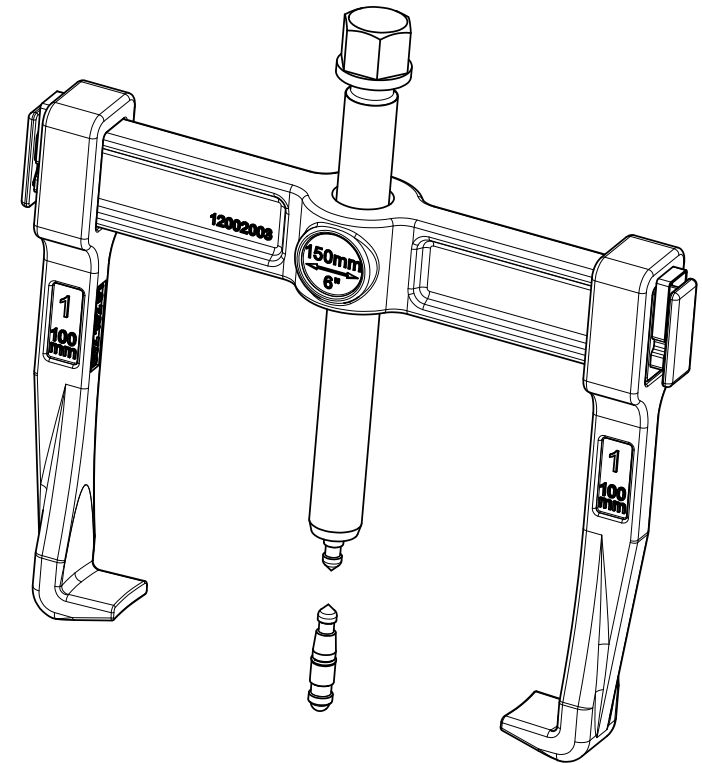
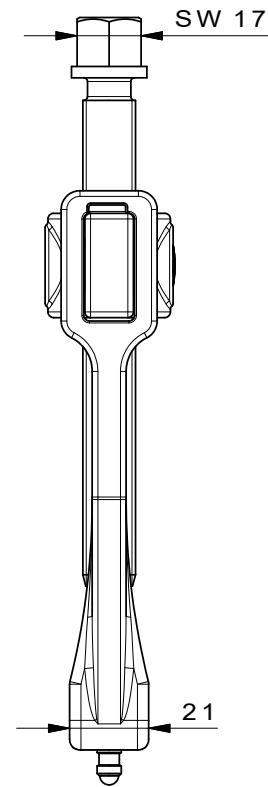
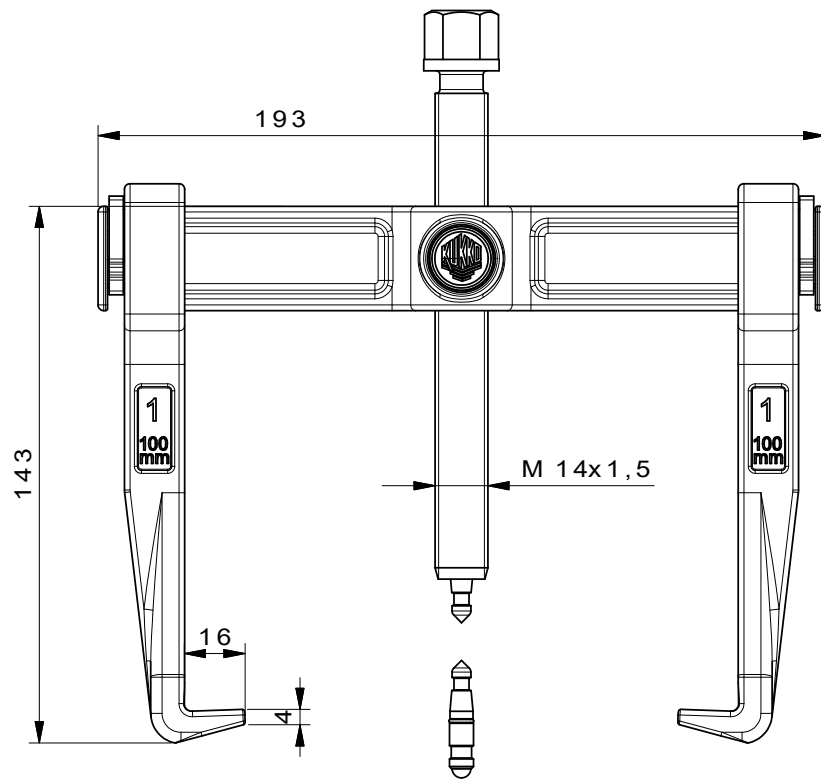

	Kleinbongartz & Kaiser oHG Werkzeugfabrik Hilden - Germany		Dokumentname: 120-10_2-armiger Universalabzieher-Vario	Toleranz: DIN ISO 2768-m
	Dokumentbeschreibung: Baugruppe		Material: Hoch legierter Werkzeugstahl / High alloy tool steel	Maßstab: 1:1
Teilbeschreibung: 2-armiger Universalabzieher-Vario/ Universal 2-jaw puller "Vario"		Erstellt von: Schultes	Erstellungsdatum: 11/04/2016	Wärmebehandlung / Härte: vergüteter Stahl/ tempered steel
Artikelnummer / ZNR.: 120-10		Dokumentversion: -	Oberflächenbehandlung: -	
Schutzvermerk ISO 16016 beachten				