



Nome del prodotto *

Estrattore universale a 2 bracci "Economy"







Per l'estrazione di cuscinetti, ingranaggi, pulegge ecc.

Num. art. 120-2

Serie 120

EAN 4021176918636



	Attributo tecnico	Metrico	Imperiale
	Ampiezza di serraggio esterna	50 - 150 mm	2 - 5 7/8 inch
	Profondità di serraggio	150 mm	5 7/8 inch
	Esagono esterno	17 mm	
max.	Carico massimo consentito	3 t	3,30 US t
	Peso	1.28 kg	
	Spazio sotto	9 mm	3/8 inch
	Spazio adiacente	32 mm	1 1/4 inch
	Numero delle griffe	2	2



Tecnologie



PUSH TO UNLOCK

Sistema di sbloccaggio per il fissaggio sicuro e una semplice rimozione del blocco di ritenuta.



SWITCH

Adattamento ottimale dei mandrini all'albero grazie alla punta bilaterale dei mandrini.



Pezzo di ricambio

Num. art.	Nome del prodotto
614160	Vite di pressione meccanica.
120-2-T	Traversa
0-148-P	2 griffe (paio)

Acessori

Num. art.	Nome del prodotto
K-600-014	Set di pressori intercambiabili per viti di pressione KUKKO

é parte di

Num. art.	Nome del prodotto
120-ST	Display di vendita "Economy"



é pezzo di ricambio di

Num. art.

Nome del prodotto

120-ST

Display di vendita "Economy"

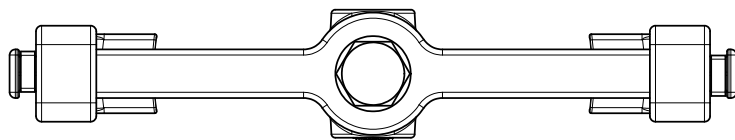
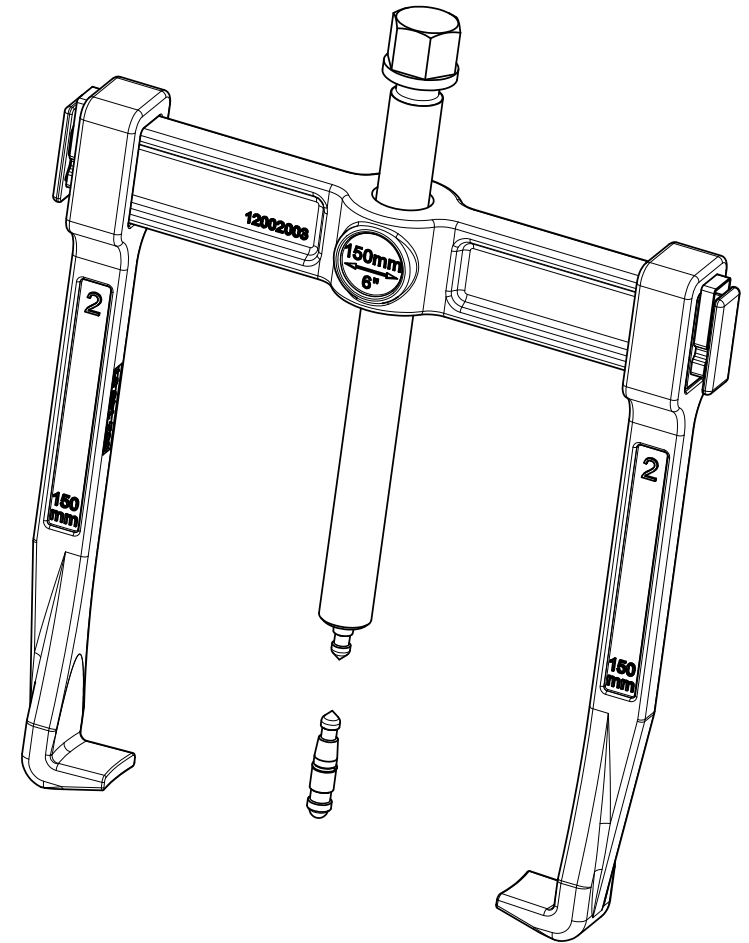
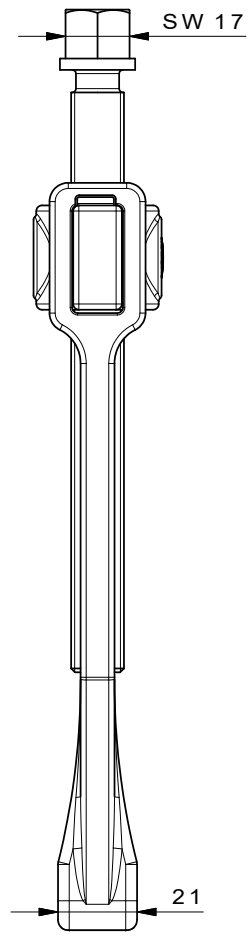
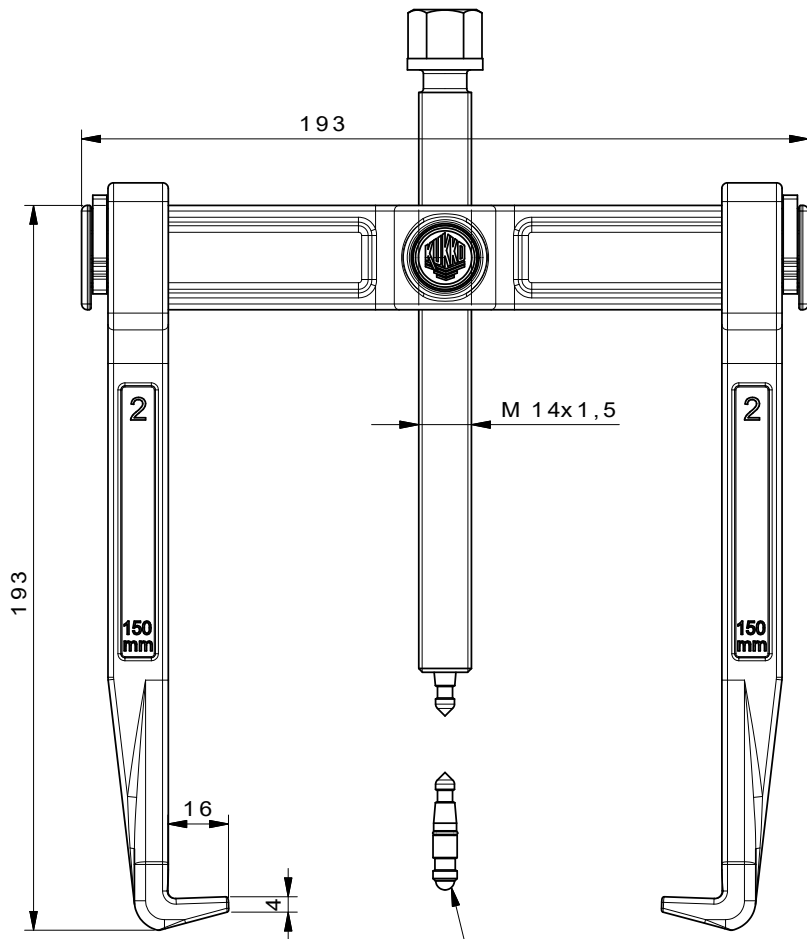

Mit Wechseldruckstück

 Kleinbongartz & Kaiser oHG Werkzeugfabrik Hilden - Germany	Dokumentname: 120-2_2-armiger Universalabzieher-Vario	Toleranz: DIN ISO 2768-m
	Dokumentbeschreibung: Baugruppe	Material: Hoch legierter Werkzeugstahl / High alloy tool steel
Erstellt von: Schultes	Erstellungsdatum: 11/04/2016	Maßstab: 1:1
Teilbeschreibung: 2-armiger Universalabzieher-Vario/ Universal 2-jaw puller "Vario"		Wärmebehandlung / Härte: vergüteter Stahl/ tempered steel
Artikelnummer / ZNR.: 120-2		Oberflächenbehandlung: Schutzvermerk ISO 16016 beachten