



Ürün adı *

2 kollu üniversal çektilme "Economy"







Yatakları, dişlileri, rondelaları vb. çıkarmak için.

Ürün No. 120-3

Seriler 120

EAN 4021176918711



	Teknik özellik	Metrik	İmparatorluk
	Derinlik	200 mm	7 7/8 inch
	Açılma genişliği	60 - 250 mm	2 3/8 - 9 7/8 inch
	Altıköşe geçme (erkek)	24 mm	
max.	İzin verilen maksimum yük	3 t	3,30 US t
	Ağırlık	3.84 kg	
	Raum unterhalb	15 mm	5/8 inch
	Raum nebendran	43 mm	1 3/4 inch
	Çene sayısı	2	2



Teknolojiler



PUSH TO UNLOCK

Hızlı tespit ve kolay kurma için serbest bırakma sistemi.



SWITCH

İki taraflı mil ucu sayesinde milin şaftla optimum uyumu.



Yedek parça

Ürün No.	Ürün adı
623230	Mekanik mil
120-3-T	Gövde
0-200-P	2 çektirme kolu (çift)

Aksesuarlar

Ürün No.	Ürün adı
K-600-025	KUKKO Milleri için, "6'sı 1 arada" değiştirilebilir Mil Uç Geçme Parçaları

Parçasıdır

Ürün No.	Ürün adı
120-ST	Satış için pano "Ekonomik"



In yedek parçası

Ürün No.

Ürün adı

120-ST

Satış için pano "Economik"

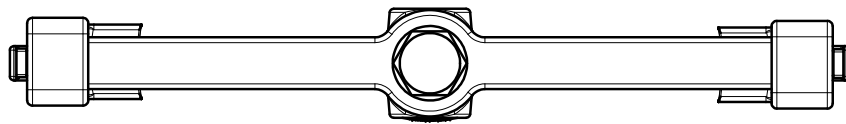
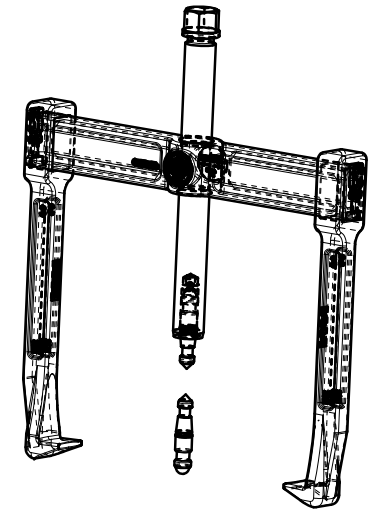
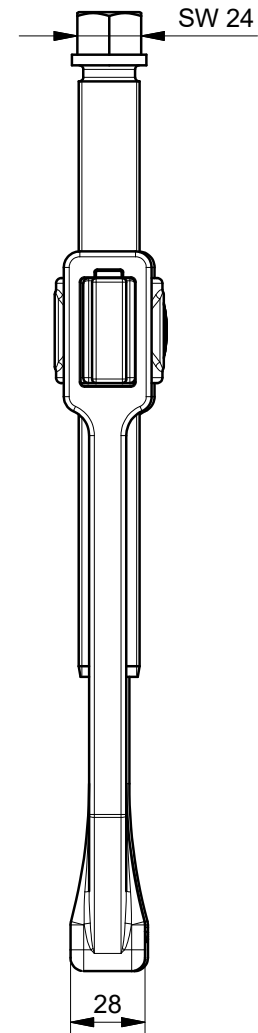
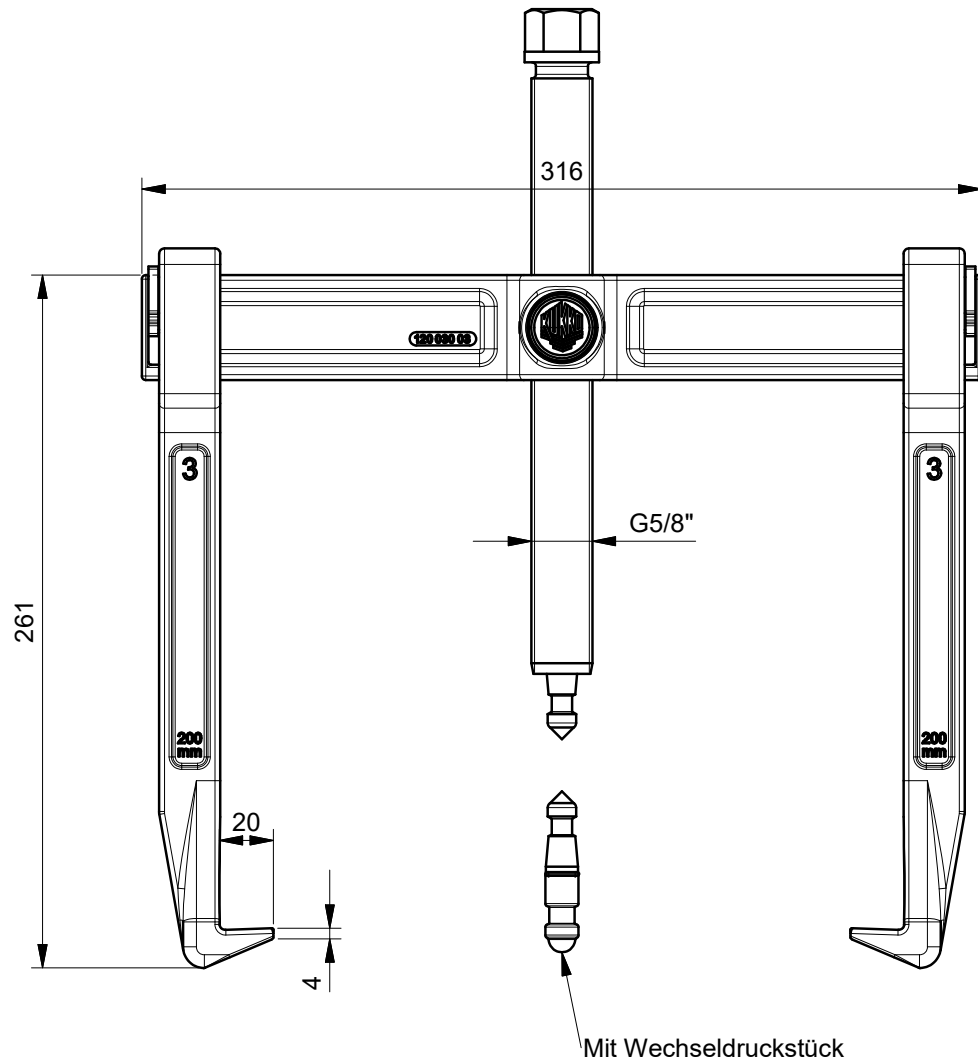

Mit Wechseldruckstück

 Kleinbongartz & Kaiser oHG Werkzeugfabrik Hilden - Germany	Dokumentname: 120-3_2-armiger Universalabzieher-Vario		Toleranz: DIN ISO 2768-m
	Dokumentbeschreibung: Baugruppe		Material: Hoch legierter Werkzeugstahl / High alloy tool steel
Erstellt von: Breidenbach	Erstellungsdatum: 13/10/2017	Maßstab: 1:2	
Teilbeschreibung: 2-armiger Universalabzieher-Vario/ Universal 2-jaw puller "Vario"		Wärmebehandlung / Härte: vergüteter Stahl/ tempered steel	
		Oberflächenbehandlung:	
Artikelnummer / ZNR.: 120-10	Dokumentversion: -	Schutzvermerk ISO 16016 beachten	