



Nazwa produktu \*

## Wyciskacz do przegubów kulowych z mechanizmem dźwigniowym





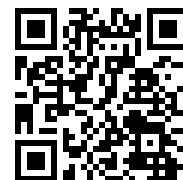

Do wyciskania sworzni kulistych przy demontażu przegubów kulowych, jak również do wyciskania główek drążków kierowniczych w samochodach osobowych i lekkich samochodach dostawczych.

Numer artykułu 129-0-25

Seria 129

EAN 4021176989667



	Cecha techniczna	Metryczne	Imperial
	Rozwarcie widełek	25 mm	1 inch
	Zakres rozwarcia dźwigni	50 mm	2 inch
 DIN ISO 7803	Do przegubów kulowych o wartości nominalnej	27 - 30 mm	
für for	Zastosowanie	VAG, universal, kleinere Modelle / smaller models	VAG, universal, kleinere Modelle / smaller models
	Ciężar	1.26 kg	
 max.	Maksymalny moment obrotowy	45 Nm	33.1 ft lb
max.	Dopuszczalne obciążenie	6,5 t	7.1 US t
	Maulhöhe min.	3,3 - 11,5 mm	1/8 - 1/2 inch
	Maulhöhe max.	mm	inch

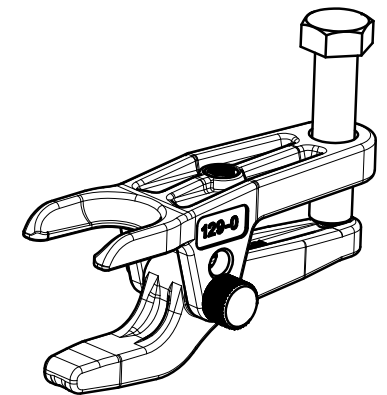
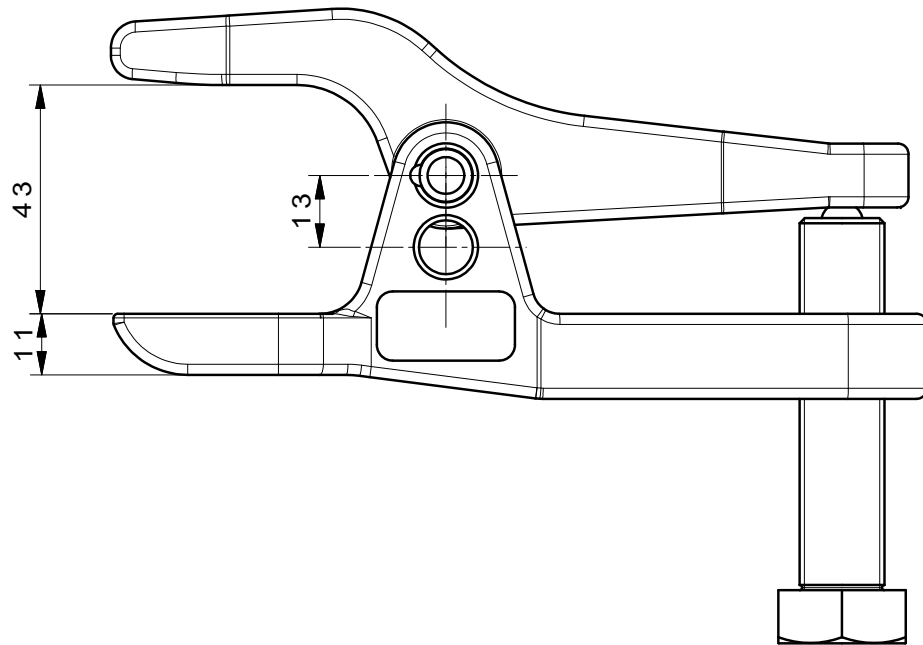
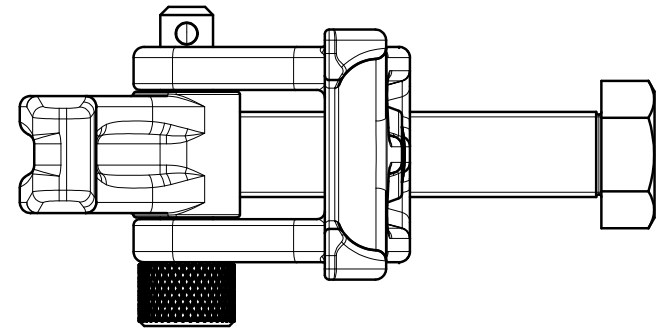
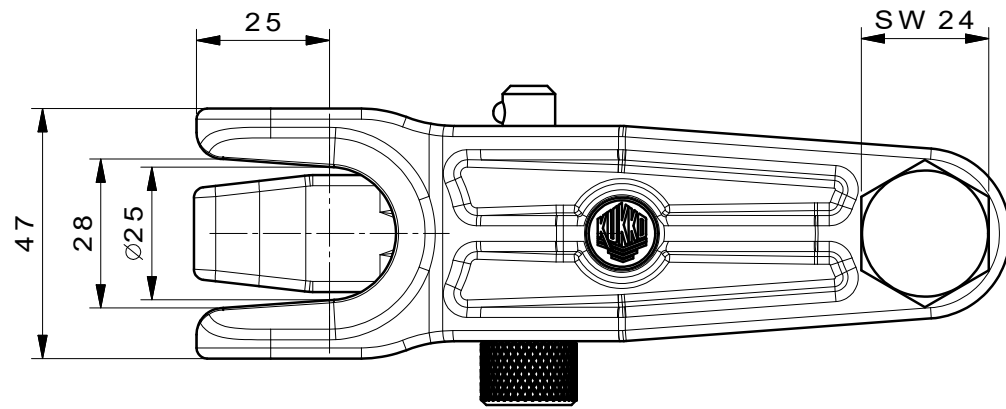

 <b>Kleinbongartz &amp; Kaiser oHG</b> Werkzeugfabrik Hilden - Germany	Dokumentname: 129-0-25_Kugelgelenk-Ausdrücker		Toleranz: DIN ISO 2768-m	
	Dokumentbeschreibung: BAUGRUPPENZEICHUNG		Material: Hoch legierter Werkzeugstahl / High alloy tool steel	
Erstellt von: Breidenbach	Erstellungsdatum: 07/12/2016	Maßstab: 1:1		
Teilbeschreibung: Kugelgelenk-Ausdrücker mit Hebelübersetzung für PKW/ Adjustable ball joint extractors lever type			Wärmebehandlung / Härte: vergüteter Stahl/ tempered steel	
Oberflächenbehandlung:			Schutzvermerk ISO 16016 beachten	
Artikelnummer / ZNR.: 129-0		Dokumentversion: -		