



Nom du produit

Arrache rotules modèles avec levier









Pour l'arrachage de pivots à rotules lors du démontage de rotules, ainsi que de têtes de barres d'accouplement, sur des véhicules particuliers et camionnettes légères.

Réf. 129-0

Gammes 129

Code à barre 4021176410536



	Caractéristique technique	Métrique	Impérial
	Ouverture de fourche	20 mm	3/4 inch
	Zone de serrage du levier	50 mm	2 inch
 DIN ISO 7803	Pour rotules de la taille nominale	27 - 30 mm	
 für for	Utilisation	universal	universal
	Poids	1.225 kg	
 max.	Moment de couple max.	45 Nm	33.1 ft lb
 max.	Charge maximale admissible	6,5 t	7.1 US t
	Hauteur de mâchoire min.	2 - 11,5 mm	1/8 - 1/2 inch
	Hauteur de mâchoire max.	mm	inch

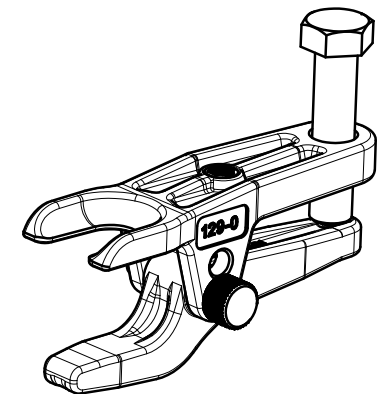
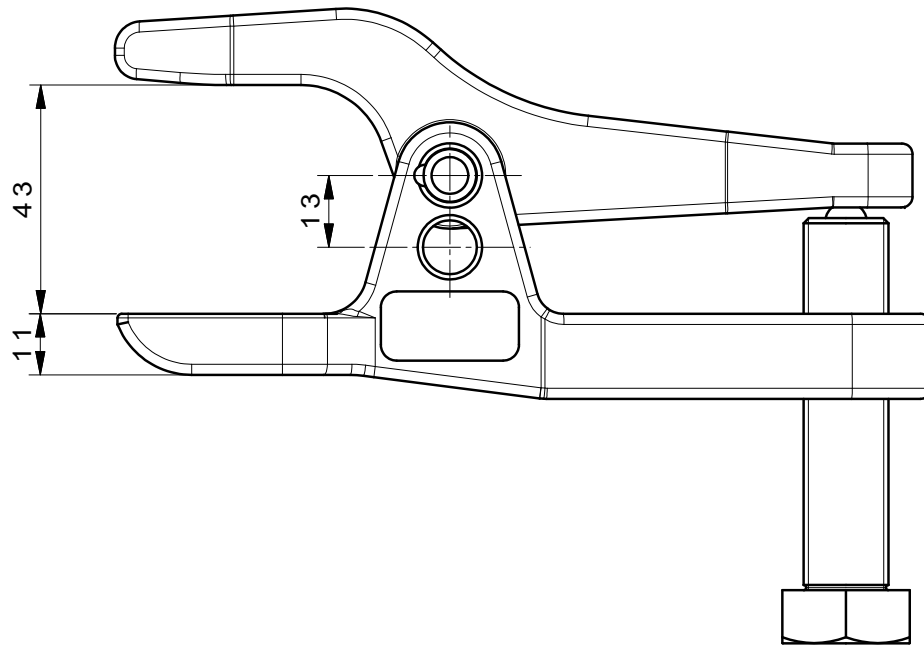
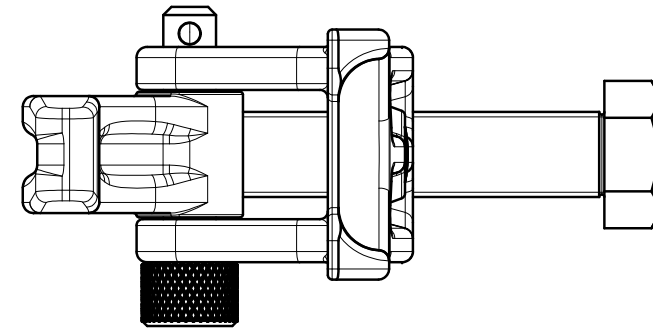
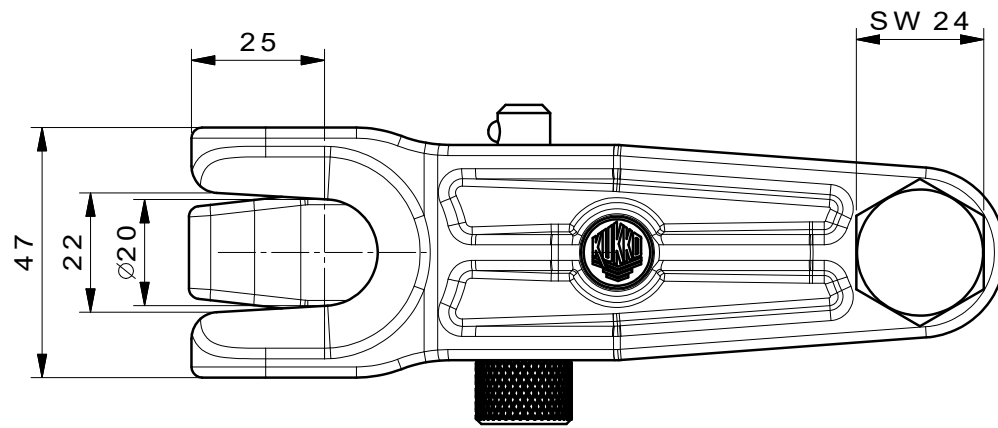

 Kleinbongartz & Kaiser oHG Werkzeugfabrik Hilden - Germany	Dokumentname: 129-0_Kugelgelenk-Ausdrücker		Toleranz: DIN ISO 2768-m
	Dokumentbeschreibung: BAUGRUPPENZEICHUNG		Material: Hoch legierter Werkzeugstahl / High alloy tool steel
Erstellt von: Breidenbach	Erstellungsdatum: 07/12/2016	Maßstab: 1:1	
Teilbeschreibung: Kugelgelenk-Ausdrücker mit Hebelübersetzung für PKW/ Adjustable ball joint extractors lever type			Wärmebehandlung / Härte: vergüteter Stahl/ tempered steel
Oberflächenbehandlung:			Schutzvermerk ISO 16016 beachten
Artikelnummer / ZNR.: 129-0	Dokumentversion: -		