



Nome del prodotto

Estrattore universale a 3 bracci "Economy"

Per l'estrazione di cuscinetti, ingranaggi, pulegge ecc.

Num. art. 130-2

Serie 130

EAN 4021176918872

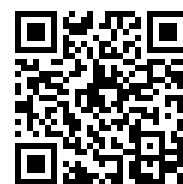

	Attributo tecnico	Metrico	Imperiale
	Ampiezza di serraggio esterna	50 - 150 mm	2 - 5 7/8 inch
	Profondità di serraggio	150 mm	5 7/8 inch
	Esagono esterno	17 mm	
max.	Carico massimo consentito	3,5 t	3,85 US t
	Peso	1.75 kg	
	Spazio sotto	9 mm	3/8 inch
	Spazio adiacente	32 mm	1 1/4 inch
	Numero delle griffe	3	3



Tecnologie



PUSH TO UNLOCK

Sistema di sbloccaggio per il fissaggio sicuro e una semplice rimozione del blocco di ritenuta.



SWITCH

Adattamento ottimale dei mandrini all'albero grazie alla punta bilaterale dei mandrini.



Pezzo di ricambio

Num. art.	Nome del prodotto
614160	Vite di pressione meccanica.
130-2-T	Traversa
0-148-S	3 griffe (set)

Acessori

Num. art.	Nome del prodotto
K-600-014	Set di pressori intercambiabili per viti di pressione KUKKO

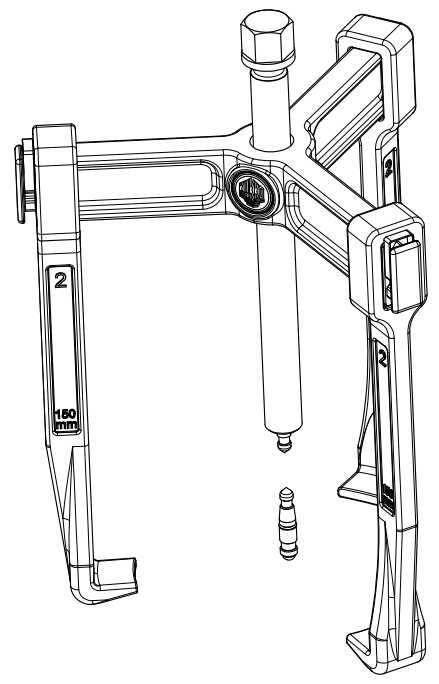
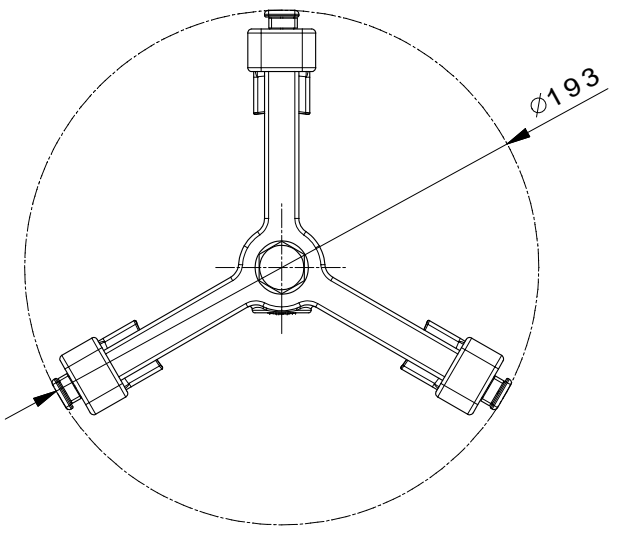
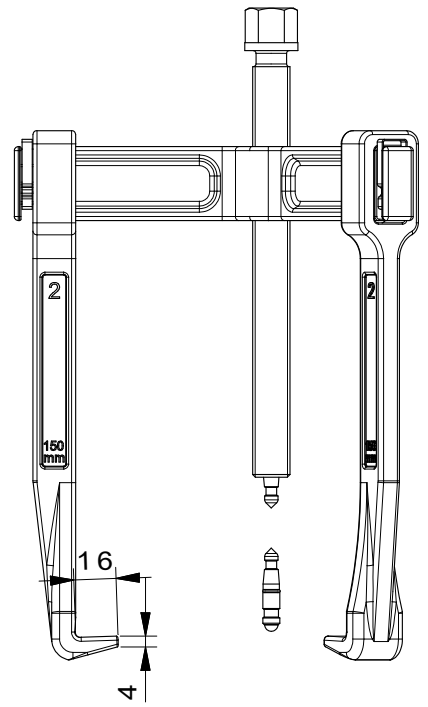
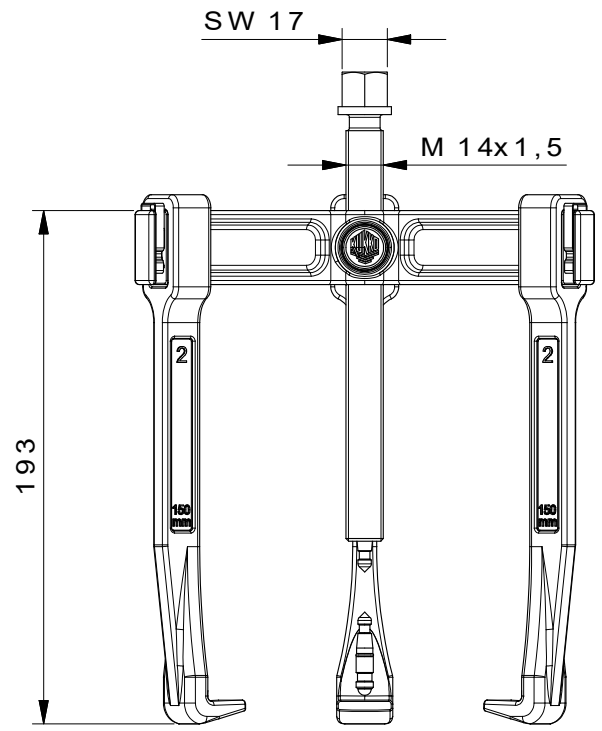

	Kleinbongartz & Kaiser oHG Werkzeugfabrik Hilden - Germany	Dokumentname: 130-2_3-armiger Universalabzieher-Vario	Teilname: DIN ISO 2768-m
	Dokumentbeschreibung: Baugruppe	Erstellt von: Breidenbach	Änderungsdatum: 11/04/2016
Teilbeschreibung: 3-armiger Universalabzieher-Vario/ Universal 3-jaw puller "Vario"	Wärmebehandlung / Heat: vergüteter Stahl/ tempered steel	Maßstab: 1:1	Oberflächenbehandlung: -
Artikelnummer / ZNR: 130-2	Dokumentversion: -	Schlüsselvermerk: ISO 16046 beachten	