



Nazwa produktu

## Ściągacz 3-ramienny uniwersalny „Economy”





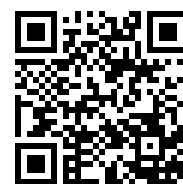

Do ściągania łożysk, kół zębatach, tarcz, itp.

Numer artykułu 130-3

Seria 130

EAN 4021176918957



	Cecha techniczna	Metryczne	Imperial
	Odległość mocowania zewnętrzna	60 - 250 mm	2 3/8 - 9 7/8 inch
	Głębokość mocowania	200 mm	7 7/8 inch
	Zewnętrzny łeb walcowy o gnieździe sześciokątnym	24 mm	
max.	Dopuszczalne obciążenie	7 t	7,71 US t
	Ciężar	5.365 kg	
	Przeźrzenie poniżej	15 mm	5/8 inch
	Raum nebendran	43 mm	1 3/4 inch
	Liczba ramion	3	3



## Technologie



### **PUSH TO UNLOCK**

System odblokowujący do szybkiego mocowania i łatwego odbezpieczenia.



### **SWITCH**

Optymalne dopasowanie wrzeciona do wału dzięki dwustronnej końcówce wrzeciona.





## Części zamienne

<b>Numer artykułu</b>	<b>Nazwa produktu</b>
623230	Mechaniczne wrzeciono naciskowe.
130-3-T	Poprzeczka ściągacza
0-200-S	3 ramiona ściągacza (zestaw)

## Akcesoria

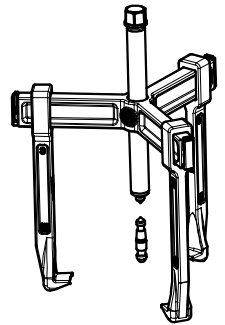
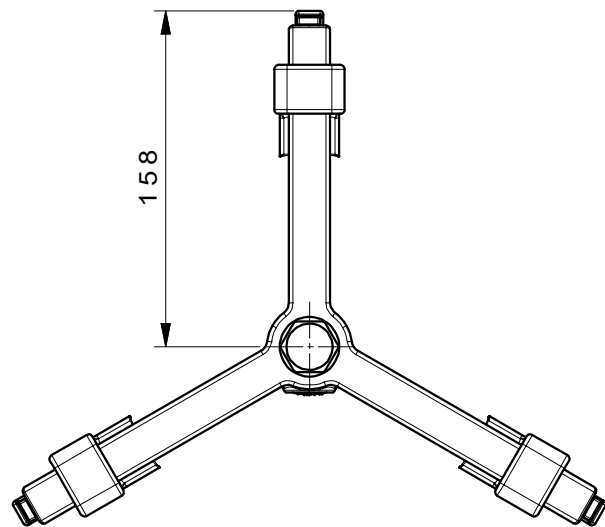
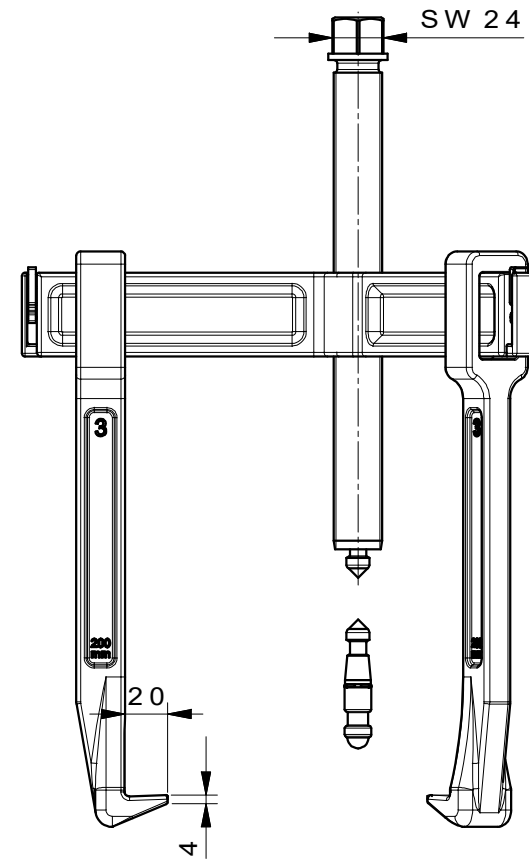
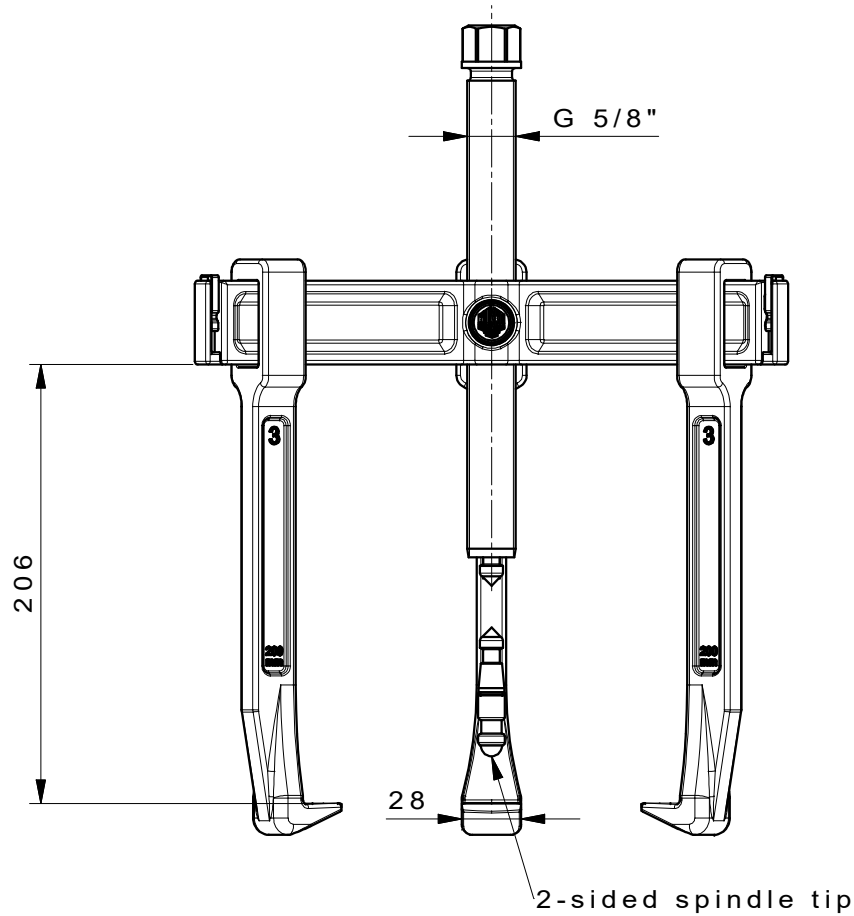
<b>Numer artykułu</b>	<b>Nazwa produktu</b>
K-600-025	Zestaw wymiennych elementów dociskowych do wrzecion KUKKO



 <b>Kleinbongartz &amp; Kaiser oHG</b> Werkzeugfabrik Hilden - Germany	Dokumentname: 130-3_3-armiger Universalabzieher-Vario		Toleranz: DIN ISO 2768-m	
	Dokumentbeschreibung: Baugruppe		Material: Hoch legierter Werkzeugstahl / High alloy tool steel	
Erstellt von: Breidenbach	Erstellungsdatum: 22/01/2019		Maßstab: 1:3	
Teilbeschreibung: 3-armiger Universalabzieher-Vario/ Universal 3-jaw puller "Vario"			Wärmebehandlung / Härte: vergüteter Stahl/ tempered steel	
			Oberflächenbehandlung: -	
Artikelnummer / ZNR.: 130-3		Dokumentversion: -	Schutzvermerk ISO 16016 beachten	