



Nome do produto

Extrator universal de 3 braços "Economy"





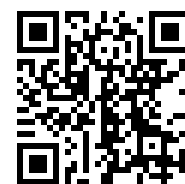

Para remover rolamentos, engrenagens, discos, etc.

Artigo Nº 130-3

Série 130

EAN 4021176918957



	Características	Métrico	Polegada
	Extensão externa	60 - 250 mm	2 3/8 - 9 7/8 inch
	Profundidade de fixação	200 mm	7 7/8 inch
	Hexágono externo	24 mm	
max.	Carga máxima permitida	7 t	7,71 US t
	Peso	5.365 kg	
	Quarto abaixo	15 mm	5/8 inch
	Quarto de drenagem secundária	43 mm	1 3/4 inch
	Número de ganchos	3	3



Tecnologias



PUSH TO UNLOCK

Sistema de desbloqueio para a fixação rápida e desbloqueio fácil.



SWITCH

Ajuste ótimo do fuso ao eixo graças à ponta do fuso de duas faces.



Peça de substituição

Artigo Nº	Nome do produto
623230	Eixo de compressão mecânico.
130-3-T	Travessa
0-200-S	3 ganchos de extração (conjunto)

Acessórios

Artigo Nº	Nome do produto
K-600-025	Peça de pressão de substituição - Conjunto para KUKKO fusos de pressão

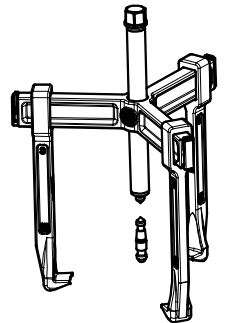
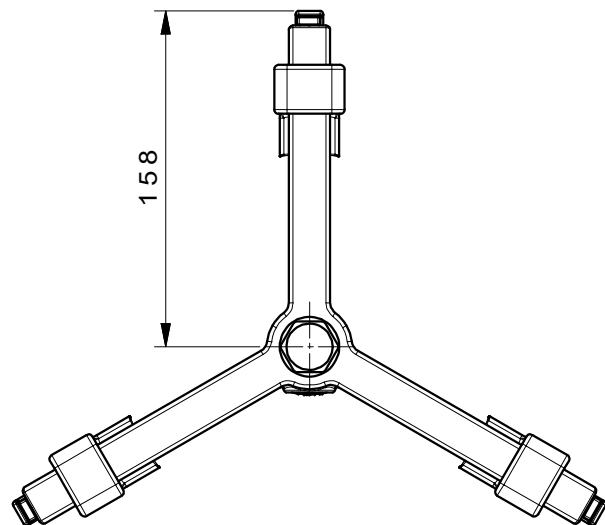
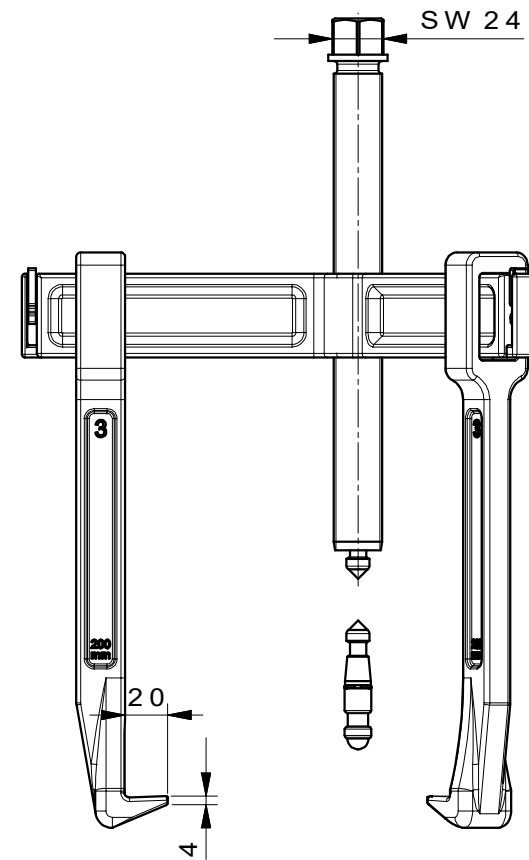
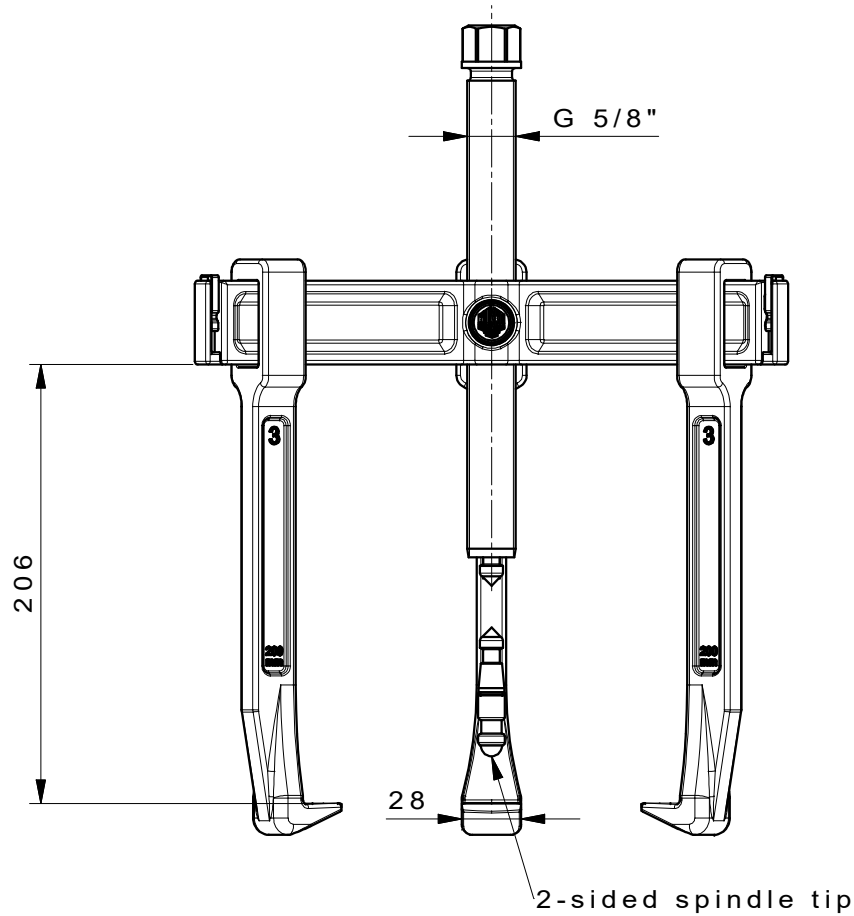

 Kleinbongartz & Kaiser oHG Werkzeugfabrik Hilden - Germany	Dokumentname: 130-3_3-armiger Universalabzieher-Vario		Toleranz: DIN ISO 2768-m	
	Dokumentbeschreibung: Baugruppe		Material: Hoch legierter Werkzeugstahl / High alloy tool steel	
Erstellt von: Breidenbach	Erstellungsdatum: 22/01/2019	Maßstab: 1:3		
Teilbeschreibung: 3-armiger Universalabzieher-Vario/ Universal 3-jaw puller "Vario"			Wärmebehandlung / Härte: vergüteter Stahl/ tempered steel	
			Oberflächenbehandlung: -	
Artikelnummer / ZNR.: 130-3	Dokumentversion: -		Schutzvermerk ISO 16016 beachten	