



Ürün adı

3 kollu üniversal çekirme "Economy"





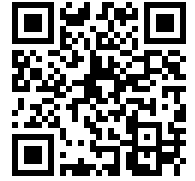

Yatakları, dişlileri, rondelaları vb. çıkarmak için.

Ürün No. 130-3

Seriler 130

EAN 4021176918957



	Teknik özellik	Metrik	Imparatorluk
	Açılma genişliği	60 - 250 mm	2 3/8 - 9 7/8 inch
	Derinlik	200 mm	7 7/8 inch
	Altıköşe geçme (erkek)	24 mm	
max.	İzin verilen maksimum yük	7 t	7,71 US t
	Ağırlık	5.365 kg	
	Raum unterhalb	15 mm	5/8 inch
	Raum nebendran	43 mm	1 3/4 inch
	Çene sayısı	3	3



Teknolojiler



PUSH TO UNLOCK

Hızlı tespit ve kolay kurma için serbest bırakma sistemi.



SWITCH

İki taraflı mil ucu sayesinde milin şaftla optimum uyumu.



Yedek parça

Ürün No.	Ürün adı
623230	Mekanik mil
130-3-T	Gövde
0-200-S	3 çektirme kolu (set)

Aksesuarlar

Ürün No.	Ürün adı
K-600-025	KUKKO Milleri için, "6'sı 1 arada" değiştirilebilir Mil Uç Geçme Parçaları

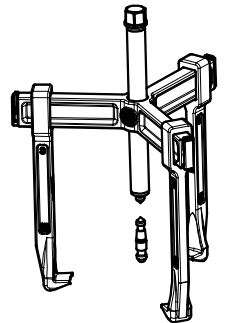
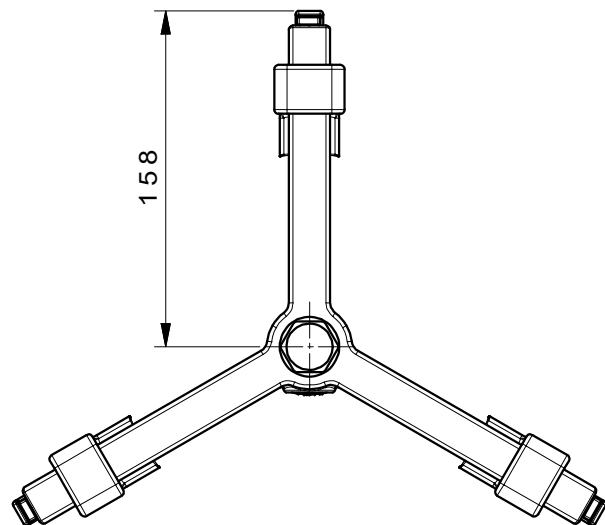
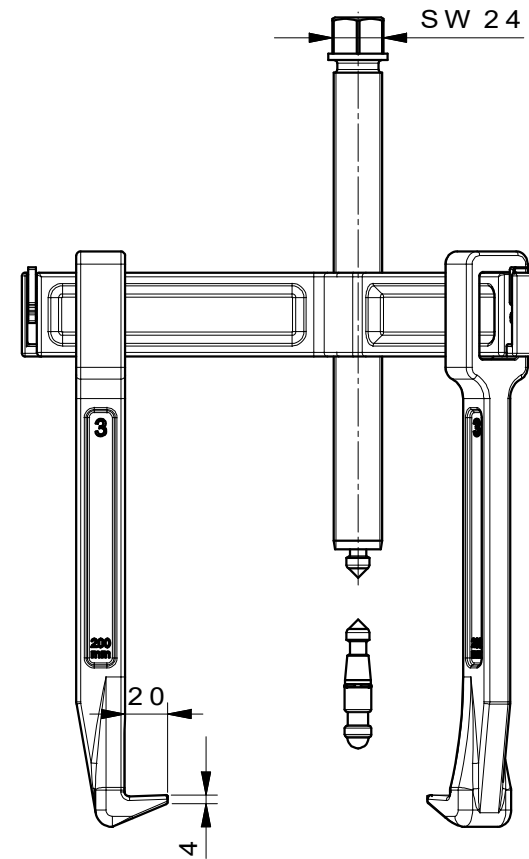
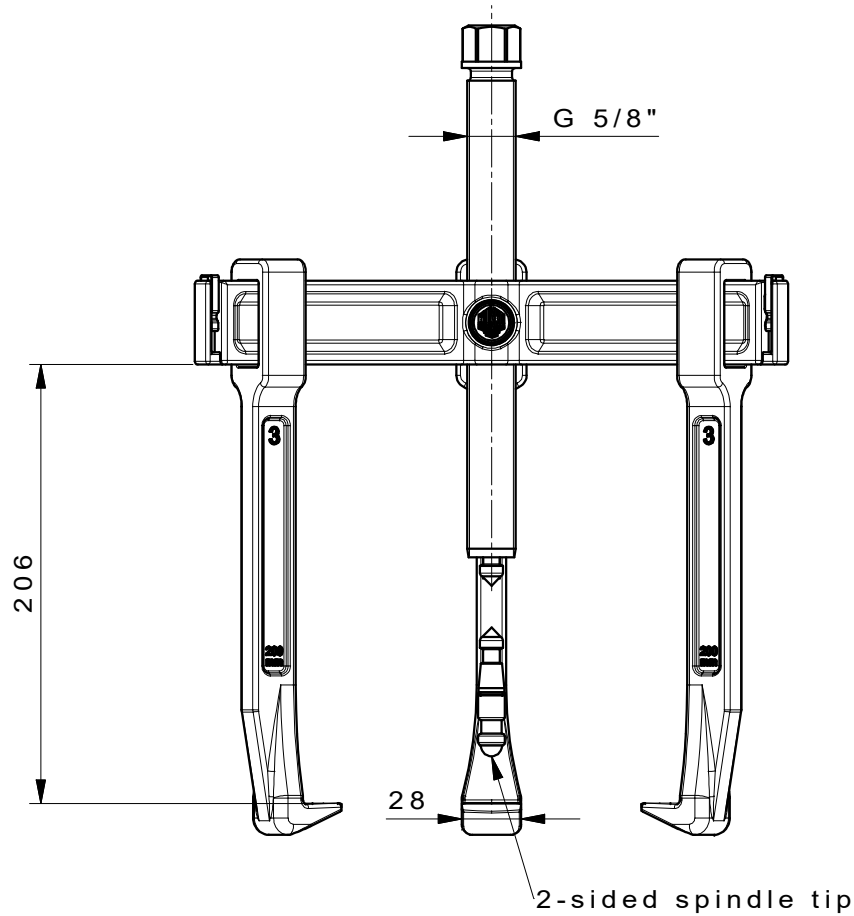

 Kleinbongartz & Kaiser oHG Werkzeugfabrik Hilden - Germany	Dokumentname: 130-3_3-armiger Universalabzieher-Vario		Toleranz: DIN ISO 2768-m	
	Dokumentbeschreibung: Baugruppe		Material: Hoch legierter Werkzeugstahl / High alloy tool steel	
Erstellt von: Breidenbach	Erstellungsdatum: 22/01/2019	Maßstab: 1:3		
Teilbeschreibung: 3-armiger Universalabzieher-Vario/ Universal 3-jaw puller "Vario"			Wärmebehandlung / Härte: vergüteter Stahl/ tempered steel	
			Oberflächenbehandlung: -	
Artikelnummer / ZNR.: 130-3	Dokumentversion: -		Schutzvermerk ISO 16016 beachten	