



Nom du produit

## Extracteur à 2 bras avec réglage rapide et crochets en croix à pieds en griffe









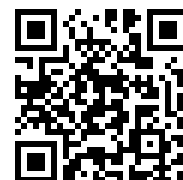

Pour les espaces étroits lors du retrait de pignons, de roulements et d'éléments similaires.

Réf. 14-01

Gammes 14

Code à barre 4021176459559



	Caractéristique technique	Métrique	Impérial
	Capacité de serrage extérieure	6 - 100 mm	1/4 - 3 7/8 inch
	Profondeur de serrage	85 mm	3 3/8 inch
	Nombre de variations de profondeur de serrage	3	3
	6 pans mâles	13 mm	
	Charge maximale admissible	1 t	1 US t
	Moment de couple max.	30 Nm	22 ft lb
	Poids	0.45 kg	
	Espace ci-dessous	2,5 mm	1/8 inch
	Pièce à côté	8,5 mm	3/8 inch
	Nombre de crochets	2	2



## Technologies



### **SWITCH**

Ajustement optimal de la tige sur l'arbre grâce à l'embout de tige.



## Pièce de rechange

Réf.	Nom du produit
612130	Vis d'extraction mécanique.
14-1-T	Entretoise
14-01-85-P	2 griffes d'extraction (paire)
060704	Paire de broches

## Accessoires

Réf.	Nom du produit
K-600-014	Set de pièces de pression pour vis d'extraction KUKKO

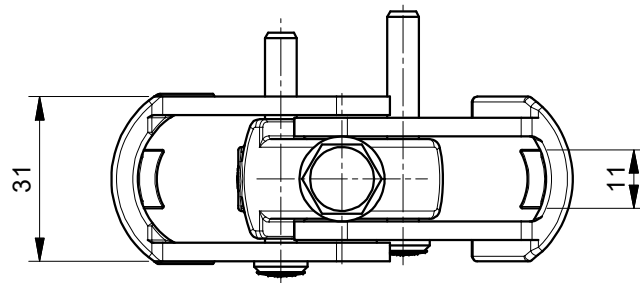
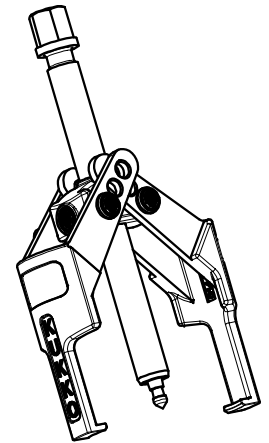
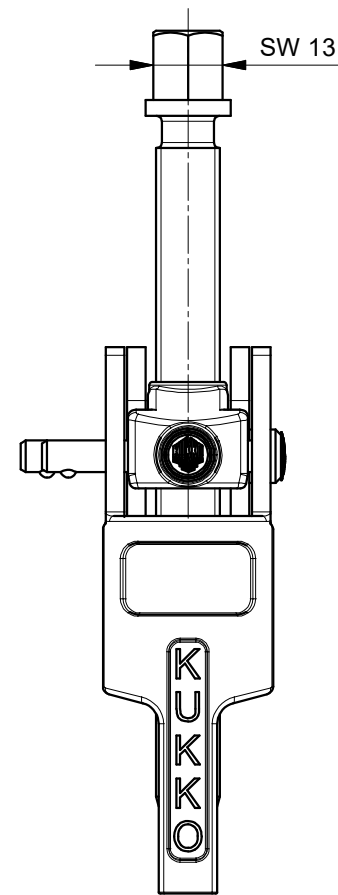
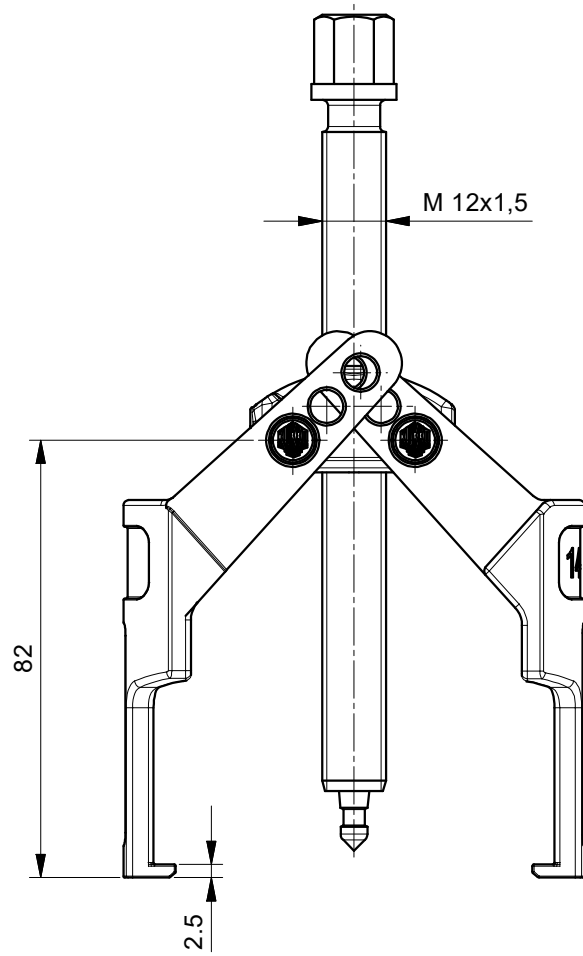

 <b>Kleinbongartz &amp; Kaiser oHG</b> <b>Werkzeugfabrik Hilden - Germany</b>	Dokumentname: <b>14-01_Abzieher mit Schnellverstellung</b>		Toleranz: <b>DIN ISO 2768-m</b>		
	Dokumentbeschreibung: <b>Baugruppe</b>			Material: <b>Hoch legierter Werkzeugstahl / High alloy tool steel</b>	
	Erstellt von: <b>Breidenbach</b>		Erstellungsdatum: <b>14/06/2018</b>		Maßstab: <b>1:1</b>
Teilbeschreibung: <b>2-armiger Abzieher mit Schnellverstellung und Kreuzhaken mit Krallenfüßen/ 2-jaw puller with quick adjusting capability and T-jaws with claw feet</b>			Wärmebehandlung / Härte: <b>vergüteter Stahl/ tempered steel</b>		
Oberflächenbehandlung:			Oberflächenbehandlung:		
Artikelnummer / ZNR.: <b>14-01</b>		Dokumentversion: <b>-</b>		Schutzvermerk <b>ISO 16016 beachten</b>	