



Product name

## Separators

For removing ball bearings, roller bearings, inner races and other tight parts if there is not enough space to use pulling hooks.

Art. No. 15-2

Series 15

EAN 4021176007118



	Technical attribute	Metric	Imperial
	Diameter of the shaft	22 - 115 mm	7/8 - 4 1/2 inch
	Distance of side screw	115 mm	4 1/2 inch
	Weight	2.9 kg	
	Space below	0 mm	0 inch
	Space next to it	115 mm	4 1/2 inch
	Spread	22 - 115 mm	7/8 - 4 1/2 inch
	Depth	250 mm	9 7/8 inch



has to be accomplished with



**Pulling device**

18-2

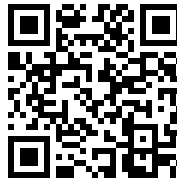

**Hydraulic pulling  
device(including  
mechanical pressure screw)**

18-2-B



## Spare part

<b>Art. No.</b>	<b>Product name</b>
015210	Side bolt with nut

## Part of

<b>Art. No.</b>	<b>Product name</b>
WT-008	Puller product range - commercial vehicles - BASIC
WT-010	Puller product range - commercial vehicles - TOP
15-B	Separating-set
30-20-T	Puller product range - industrial - BASIC
WT-50	Puller product range - industrial - TOP
K-20-15	Universal puller set with separator
29-B	Universal puller set in TANOS-Systainer®
30-20+T	Puller product range - industrial - BASIC+



## Spare part of

<b>Art. No.</b>	<b>Product name</b>
WT-008	Puller product range - commercial vehicles - BASIC
15-B	Separating-set
K-20-15	Universal puller set with separator
29-B	Universal puller set in TANOS-Systainer®

## Also included in

<b>Art. No.</b>	<b>Product name</b>
WT-008	Puller product range - commercial vehicles - BASIC
WT-010	Puller product range - commercial vehicles - TOP
30-20-T	Puller product range - industrial - BASIC
WT-50	Puller product range - industrial - TOP
K-20-15	Universal puller set with separator
30-20+T	Puller product range - industrial - BASIC+

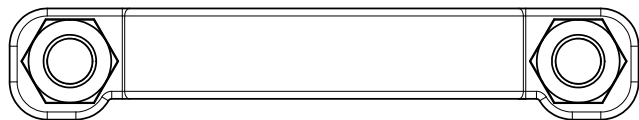
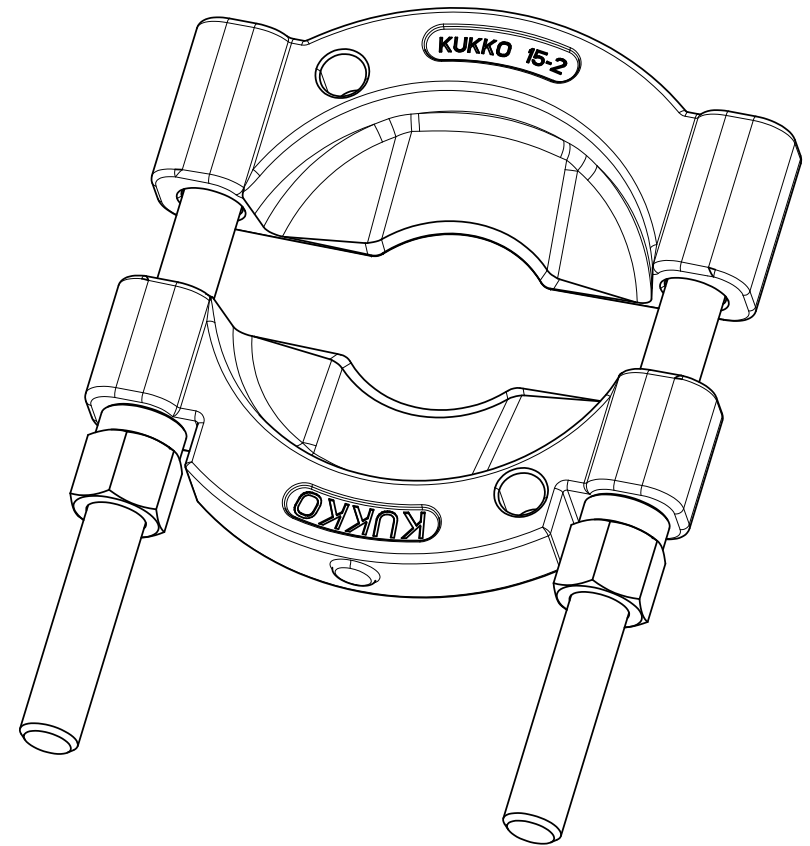
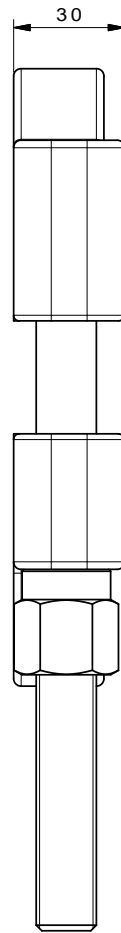
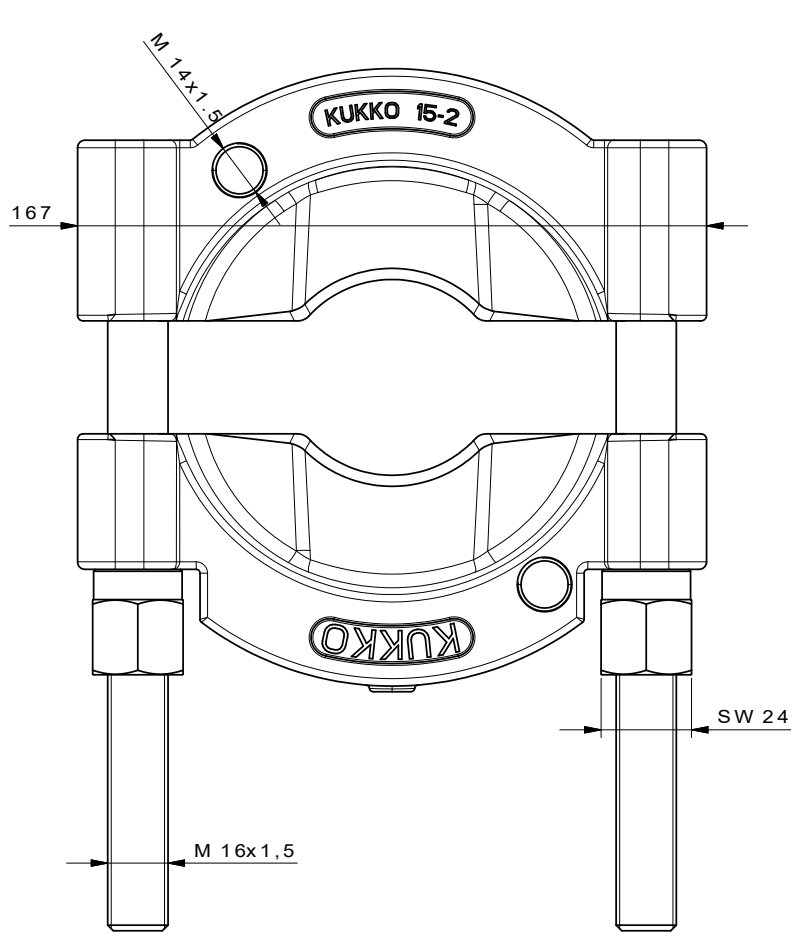

 <b>Kleinbongartz &amp; Kaiser oHG</b> <b>Werkzeugfabrik Hilden - Germany</b>	Dokumentname: <b>15-2_Trennvorrichtung</b>	Toleranz: <b>DIN ISO 2768-m</b>
	Dokumentbeschreibung: <b>Baugruppe</b>	Material: <b>Hoch legierter Werkzeugstahl / High alloy tool steel</b>
	Erstellt von: Schultes	Erstellungsdatum: 08/04/2016
Teilbeschreibung: <b>Trennvorrichtung / Separators</b>		Wärmebehandlung / Härte: <b>vergüteter Stahl/ tempered steel</b>
		Oberflächenbehandlung:
Artikelnummer / ZNR.: <b>15-2</b>	Dokumentversion: -	Schutzvermerk ISO 16016 beachten