



Nome do produto

Dispositivo de separação

Para a extração dos rolamentos de esferas, rolamentos de rolos, anéis interiores e outras peças de encaixe nivelado quando não há espaço suficiente para ganchos de extração.

Artigo Nº 15-3

Série 15

EAN 4021176007293

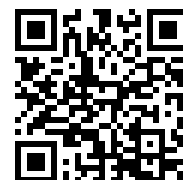

	Características	Métrico	Polegada
	Diâmetro do eixo	25 - 155 mm	1 - 6 1/8 inch
	Distância entre cavilhas laterais	155 mm	6 1/8 inch
	Peso	5.3 kg	
	Quarto abaixo	0 mm	0 inch
	Quarto de drenagem secundária	155 mm	6 1/8 inch
	Extensão externa	25 - 155 mm	1 - 6 1/8 inch
	Profundidade de fixação	300 mm	11 7/8 inch



ainda necessita de



Dispositivo de extração

18-3

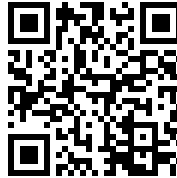

**Dispositivo de extração
hidráulico (incluindo eixo
mecânico)**

18-3-B



Peça de substituição

Artigo Nº	Nome do produto
015270	Parafuso lateral com porca

Faz parte de

Artigo Nº	Nome do produto
WT-030	Gama de extratores - Indústria automóvel – Eixos
15-C	Conjunto de dispositivo de separação

é uma peça de substituição de

Artigo Nº	Nome do produto
15-C	Conjunto de dispositivo de separação

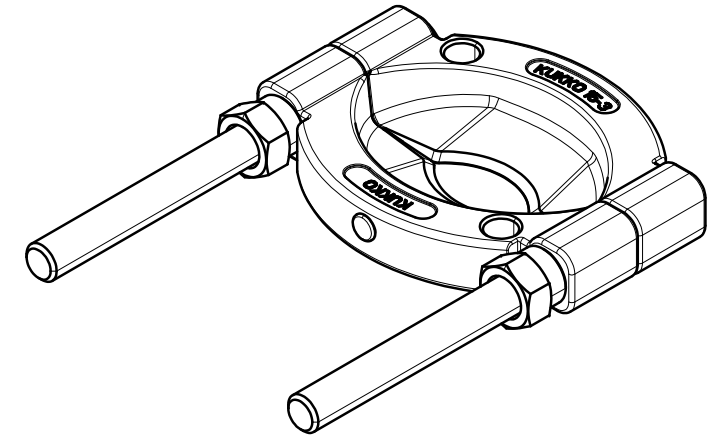
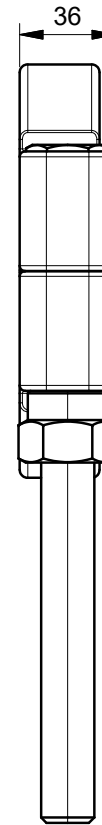
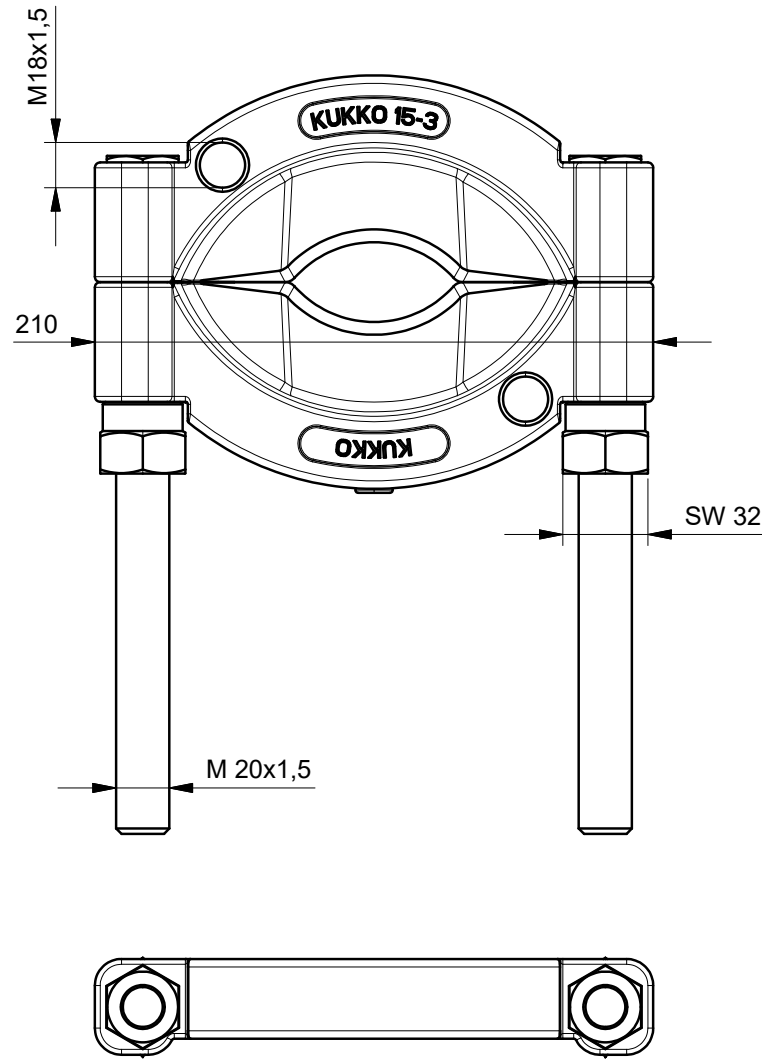

 Kleinbongartz & Kaiser oHG Werkzeugfabrik Hilden - Germany	Dokumentname: 15-3 Trennvorrichtung		Toleranz: DIN ISO 2768-m	
	Dokumentbeschreibung: Baugruppe		Material: Hoch legierter Werkzeugstahl / High alloy tool steel	
	Erstellt von: Breidenbach	Erstellungsdatum: 11/10/2017	Maßstab: 1:2	
Teilbeschreibung: Trennvorrichtung /Separators			Wärmebehandlung / Härte: vergüteter Stahl/ tempered steel	
			Oberflächenbehandlung:	
Artikelnummer / ZNR.: 15-3		Dokumentversion: -	Schutzvermerk ISO 16016 beachten	