



Product name

Separators

For removing ball bearings, roller bearings, inner races and other tight parts if there is not enough space to use pulling hooks.

Art. No. 15-4

Series 15

EAN 4021176007378

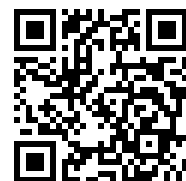

	Technical attribute	Metric	Imperial
	Diameter of the shaft	30 - 200 mm	1 3/16 - 7 7/8 inch
	Distance of side screw	200 mm	7 7/8 inch
	Weight	11.8 kg	
	Space below	0 mm	0 inch
	Space next to it	200 mm	7 7/8 inch
	Spread	30 - 200 mm	1 3/16 - 7 7/8 inch
	Depth	350 mm	13 3/4 inch



has to be accomplished with



Pulling device

18-4

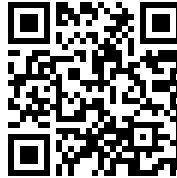

**Hydraulic pulling
device(including
mechanical pressure screw)**

18-4-B



Spare part

Art. No.	Product name
015401	Side bolt with nut

Part of

Art. No.	Product name
15-D	Separating-set

Spare part of

Art. No.	Product name
15-D	Separating-set

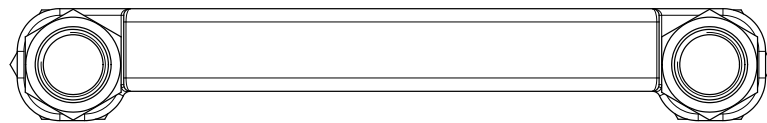
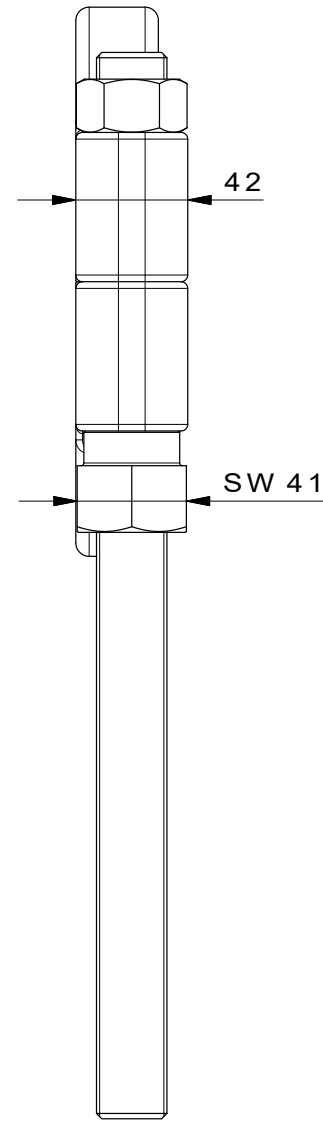
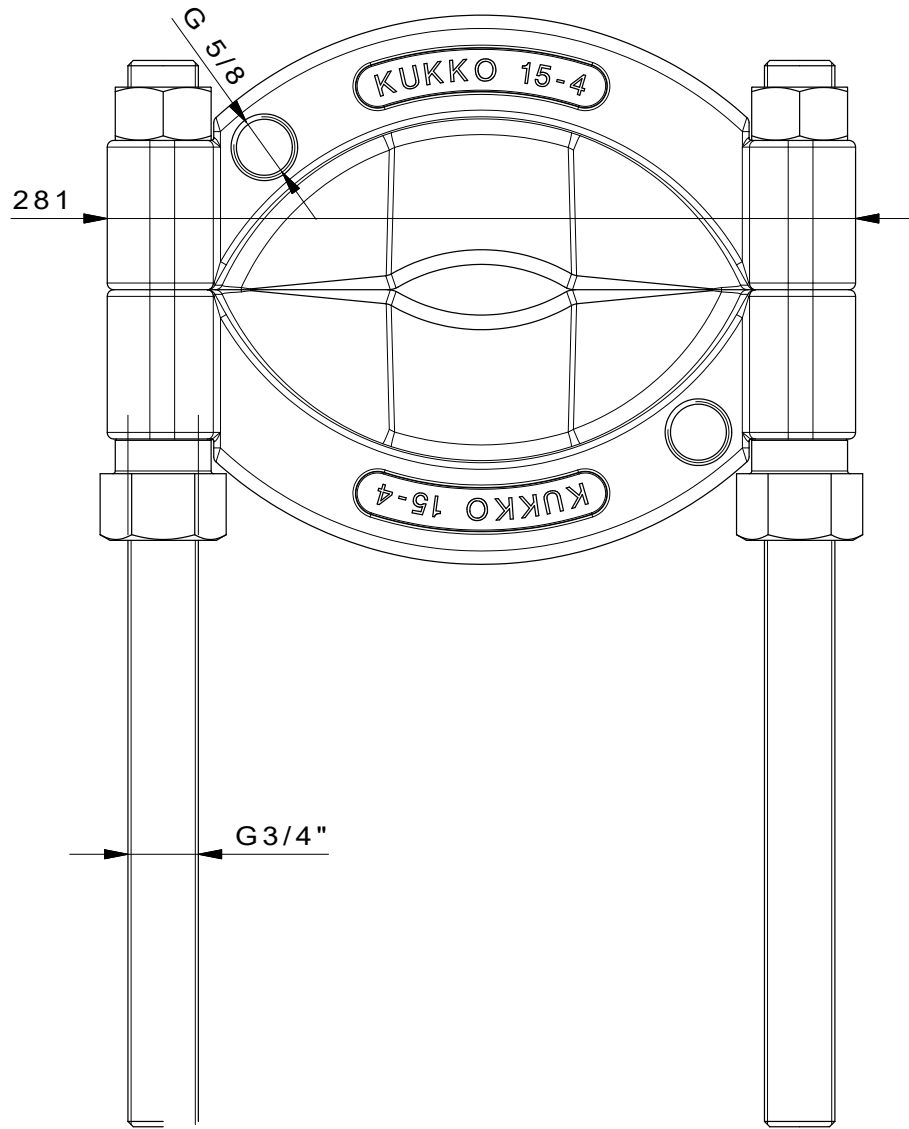

 Kleinbongartz & Kaiser oHG Werkzeugfabrik Hilden - Germany	Dokumentnr.: 15-4 Trennvorrichtung	Toleranz: DIN ISO 2768-m
	Dokumentbeschreibung: Baugruppe	Material: Hoch legierter Werkzeugstahl / High alloy tool steel
Erweit. von: Schultes	Erstellungsdatum: 13/04/2016	Wärmebehandlung / Härte: vergüteter Stahl/ tempered steel
Teilbeschreibung: Trennvorrichtung / Separators		Oberflächenbehandlung:
Artikelnummer / ZNR.: 15-4	Dokumentversion: -	Schutzvermerk: ISO 16949 zertifiziert