



Product name

Internal extractors

Art. No. 16-21

Series

EAN 4021176251559

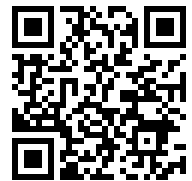

Technical attribute

Metric

Imperial



Ball bearing ISO

6012; 6212; 6312;	6012; 6212; 6312;
6412; 16012; 61812;	6412; 16012; 61812;
61912; 6013; 6213;	61912; 6013; 6213;
6313; 16013; 61913;	6313; 16013; 61913;
6014; 6214; 6314;	6014; 6214; 6314;
16014; 6015; 6215;	16014; 6015; 6215;
6315; 16015; 6016;	6315; 16015; 6016;
6216; 6316; 16016;	6216; 6316; 16016;
61816; 6017; 6217;	61816; 6017; 6217;
6317; 6018; 6218;	6317; 6018; 6218;
6318; 16018; 61818;	6318; 16018; 61818;
6219; 6319; 6020;	6219; 6319; 6020;
6220; 6320	6220; 6320



Inner diameter of ball bearing

60 - 155 mm

2 3/8 - 6 1/8 inch



Effective depth

120 mm



Length of internal extractor

237 mm



	Technisches Attribut	Metric	Imperial
 Segment	Number of segments	3	3
	Weight	3.47 kg	



has to be accomplished with

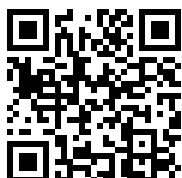

Counterstay

16-22



Spare part

Art. No.	Product name
16-21-33	3 spreaders (set)
16-21-6	Spindle

Accessories

Art. No.	Product name
016002	3 Extractor segments (set) with fixing material
VM112-12	female adapter
16-21-6	Spindle
16-21-33	3 spreaders (set)

Goes with

Art. No.	Product name
16-22	Counterstay





Part of

Art. No.	Product name
16	Cylinder liner puller
K-16	Cylinder liner puller set

Spare part of

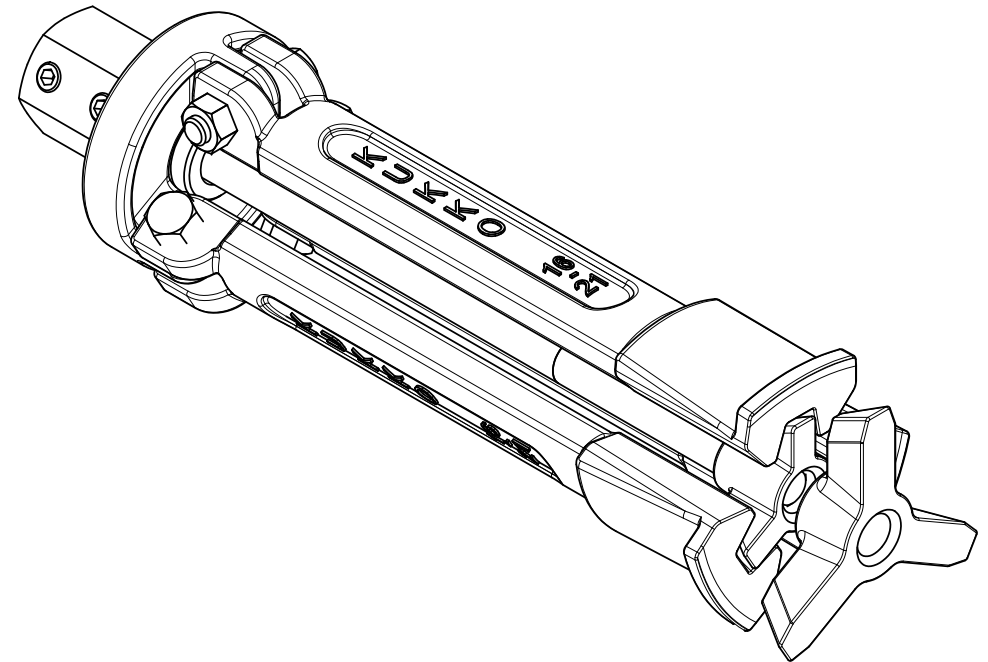
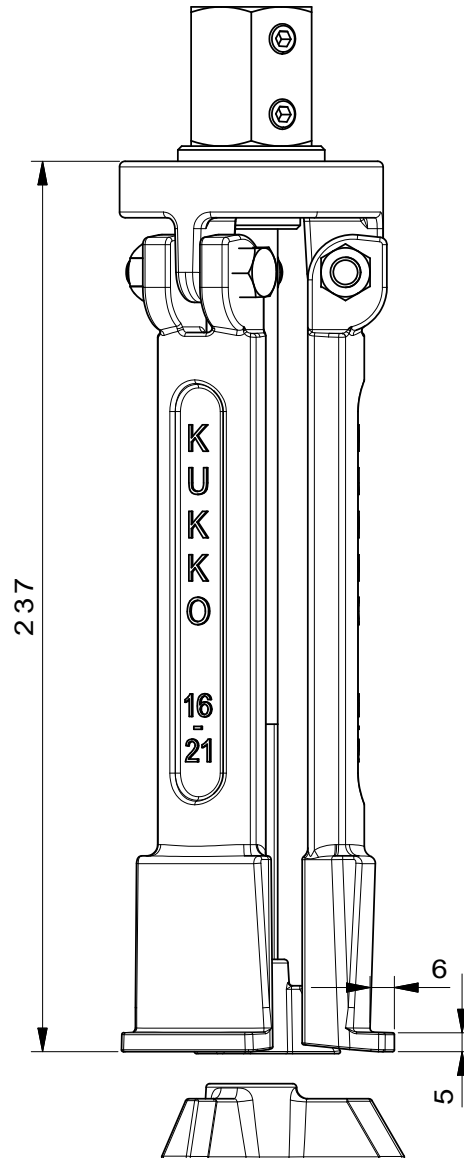
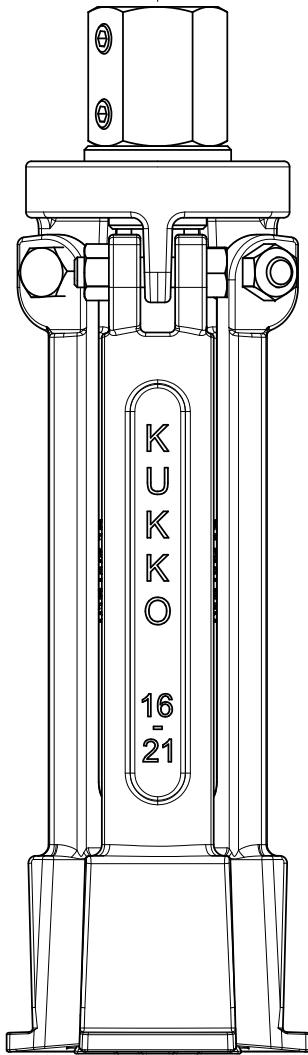
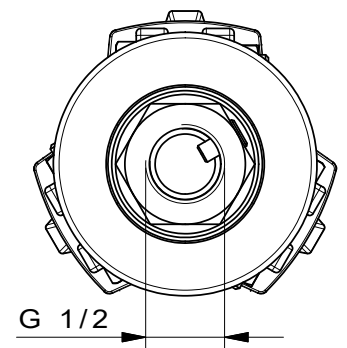
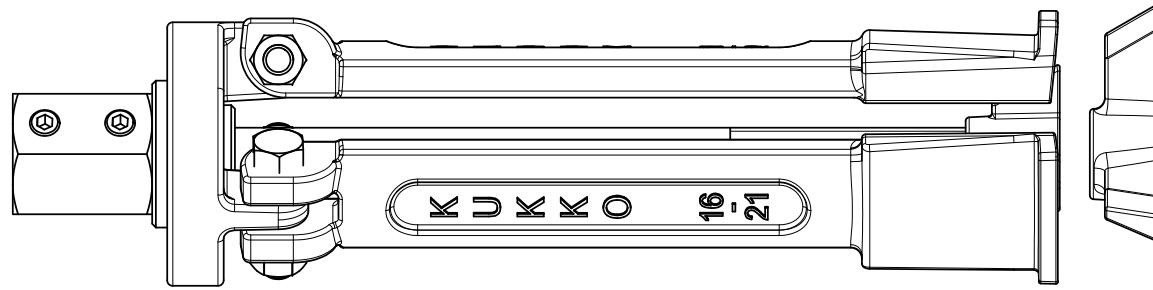
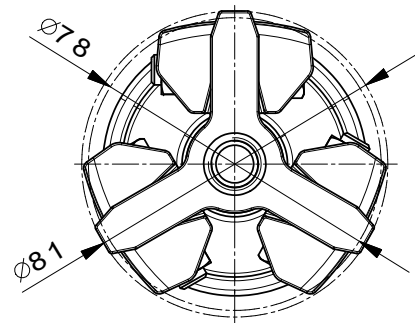
Art. No.	Product name
16	Cylinder liner puller
K-16	Cylinder liner puller set



 Kleinbongartz & Kaiser oHG Werkzeugfabrik Hilden - Germany	Dokumentname: 16-21_Zylinderbüchsenauszieher	Toleranz: DIN ISO 2768-m
	Dokumentbeschreibung: ZSB	Material: Hoch legierter Werkzeugstahl / High alloy tool steel
Erstellt / Geprüft von: Schultes	Erstellungsdatum: 05/06/2015	Maßstab: 1:1
Teilbeschreibung: Zylinderbüchsenauszieher // Internal extractors		Wärmebehandlung / Härte: vergüteter Stahl/ tempered steel
Oberflächenbehandlung:		Schutzvermerk ISO 16616 beachten
Artikelnummer / ZNR.: 16-21	Dokumentversion: -	