



Nombre del producto

## Extractor interior

Núm. art. 16-21

Serie

EAN 4021176251559

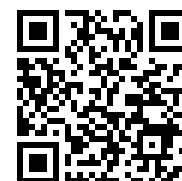

### Atributo técnico

### Métrico

### Imperial



Rodamientos de bolas ISO

6012; 6212; 6312;	6012; 6212; 6312;
6412; 16012; 61812;	6412; 16012; 61812;
61912; 6013; 6213;	61912; 6013; 6213;
6313; 16013; 61913;	6313; 16013; 61913;
6014; 6214; 6314;	6014; 6214; 6314;
16014; 6015; 6215;	16014; 6015; 6215;
6315; 16015; 6016;	6315; 16015; 6016;
6216; 6316; 16016;	6216; 6316; 16016;
61816; 6017; 6217;	61816; 6017; 6217;
6317; 6018; 6218;	6317; 6018; 6218;
6318; 16018; 61818;	6318; 16018; 61818;
6219; 6319; 6020;	6219; 6319; 6020;
6220; 6320	6220; 6320



Diámetro interior del rodamiento de bolas

60 - 155 mm

2 3/8 - 6 1/8 inch



Profundidad de uso

120 mm



Longitud del expulsor interno

237 mm



	<b>Technisches Attribut</b>	<b>Métrico</b>	<b>Imperial</b>
 Segment	Número de segmentos	3	3
	Peso	3.47 kg	



necesita de

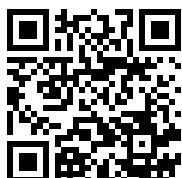

**Contraapoyo**

16-22



## Pieza de recambio

<b>Núm. art.</b>	<b>Nombre del producto</b>
16-21-33	3 abridores (juego)
16-21-6	Husillo

## Accesorios

<b>Núm. art.</b>	<b>Nombre del producto</b>
016002	3 mordazas de extracción (juego completo) con tornillos y tuercas
VM112-12	Tuerca de unión
16-21-6	Husillo
16-21-33	3 abridores (juego)

## Necesario para

<b>Núm. art.</b>	<b>Nombre del producto</b>
16-22	Contraapoyo





## Es parte de

<b>Núm. art.</b>	<b>Nombre del producto</b>
16	Estractor de camisas de cilindro
K-16	Juego de estractor de camisas de cilindro

## Es pieza de sustitucion de

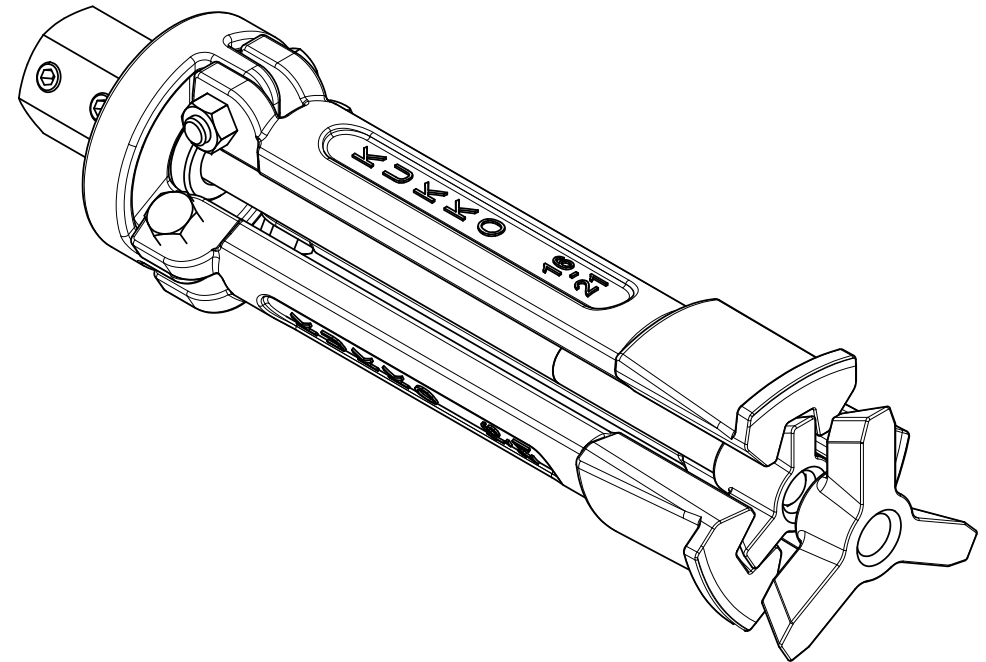
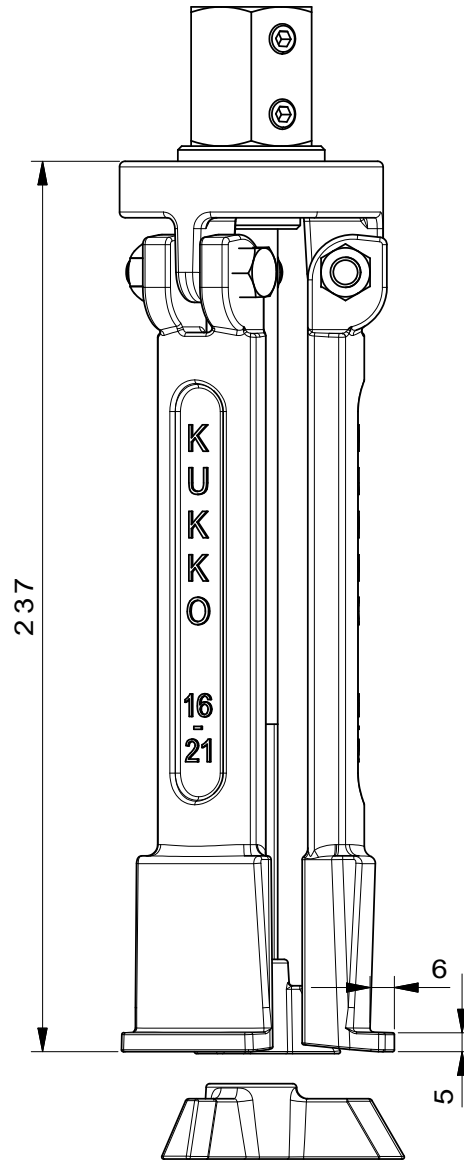
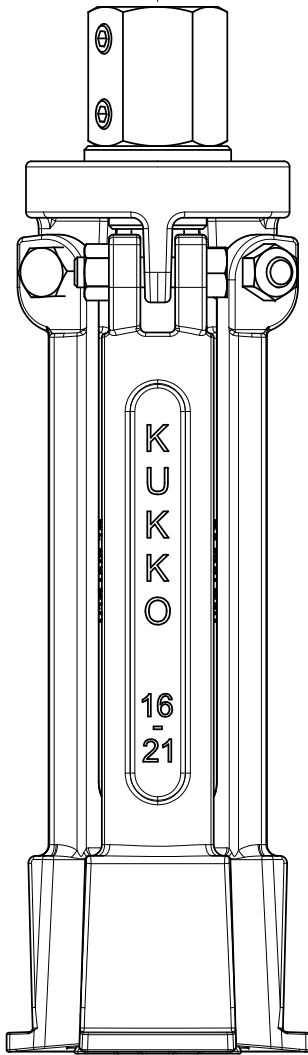
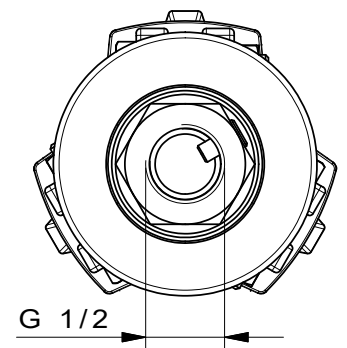
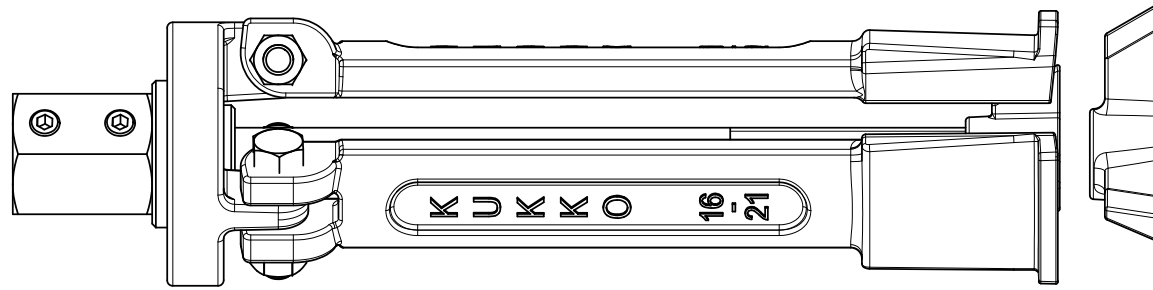
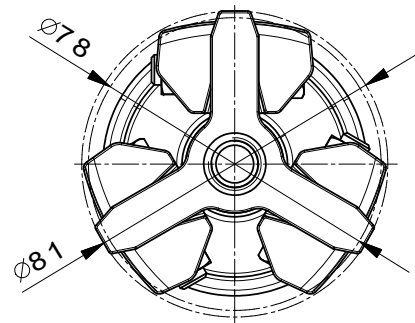
<b>Núm. art.</b>	<b>Nombre del producto</b>
16	Estractor de camisas de cilindro
K-16	Juego de estractor de camisas de cilindro



 <b>Kleinbongartz &amp; Kaiser oHG</b> Werkzeugfabrik Hilden - Germany	Dokumentname: 16-21_Zylinderbüchsenauszieher	Toleranz: DIN ISO 2768-m
	Dokumentbeschreibung: ZSB	Material: Hoch legierter Werkzeugstahl / High alloy tool steel
Erstellt / Geprüft von: Schultes	Erstellungsdatum: 05/06/2015	Maßstab: 1:1
Teilbeschreibung: Zylinderbüchsenauszieher // Internal extractors		Wärmebehandlung / Härte: vergüteter Stahl/ tempered steel
Oberflächenbehandlung:		Schutzvermerk ISO 16616 beachten
Artikelnummer / ZNR: 16-21	Dokumentversion: -	