



Produkt navn

Adskiller med trykspindel med hurtig spændefunktion







Til aftrækning af kuglelejer, rullelejer, inderringe og andre dele, som flugter med en flade, når der ikke er nok plads til aftrækningskroge.

Varenr. 17-2

Serie 17

EAN 4021176008368



| | Teknisk egenskab | Metrisk | Tomme |
|---|----------------------------|----------------|------------------|
|  | Akslens diameter | 22 - 115 mm | 7/8 - 4 1/2 inch |
|  | Afstand mellem sideboltene | 115 mm | 4 1/2 inch |
|  | Vægt | 3.72 kg | |
|  | Rum nedenunder | 0 mm | 0 inch |
|  | Rum ved siden af | 115 mm | 4 1/2 inch |
|  | Spændvidde udvendig | 22 - 22 mm | 7/8 - 7/8 inch |
|  | Spænddybde | 250 mm | 9 7/8 inch |



Skal udføres med

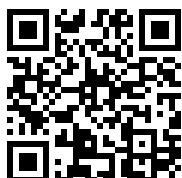

Aftrækker

18-2

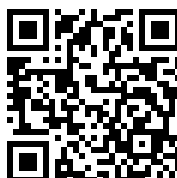

**Hydraulisk aftrækker
(inklusive mekanisk
spindel)**

18-2-B



Reservedel

| Varenr. | Produkt navn |
|---------|-----------------------|
| 618105 | Mekanisk trykspindel. |
| 17-2-T | Travers |
| 17-2-06 | Spindel |
| 017235 | Sidebolt med møtrik |

Er bestanddel af

| Varenr. | Produkt navn |
|----------------------|--|
| 17-B | Adskillersæt med trykspindel med hurtig spændefunktion |
| WT-019 | Aftrækkersortiment - adskillende aftrækning |
| K-20+17-C | Universal adskillelses- og aftrækkersæt |
| K-20+17 | Universal adskillelses- og aftrækkersæt |
| EVLW-INDUSTRIE BASIC | Salgsvæg industri |



Er reservedel til

Varenr.

Produktnavn

17-B

Adskillersæt med trykspindel med hurtig spændefunktion

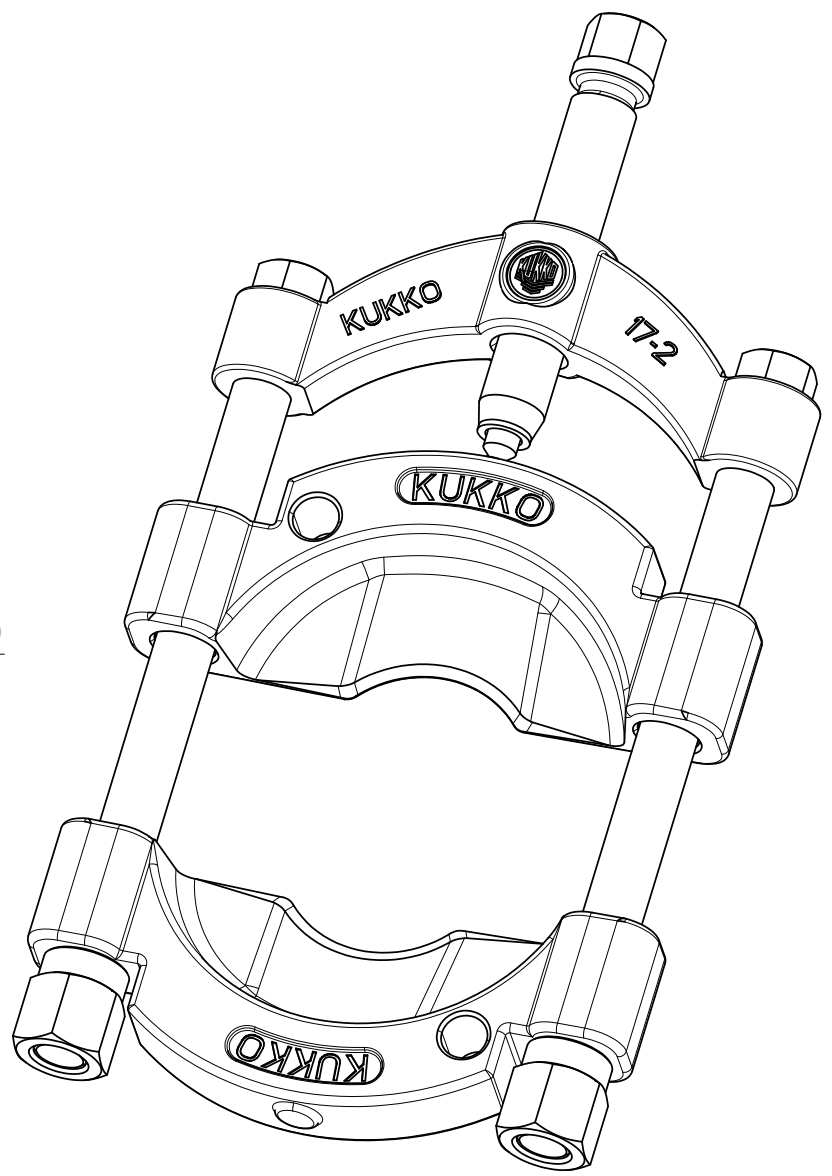
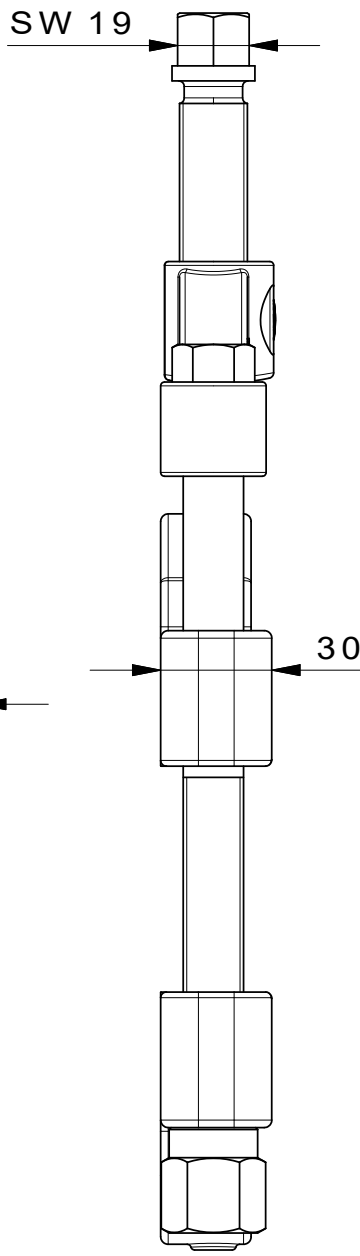
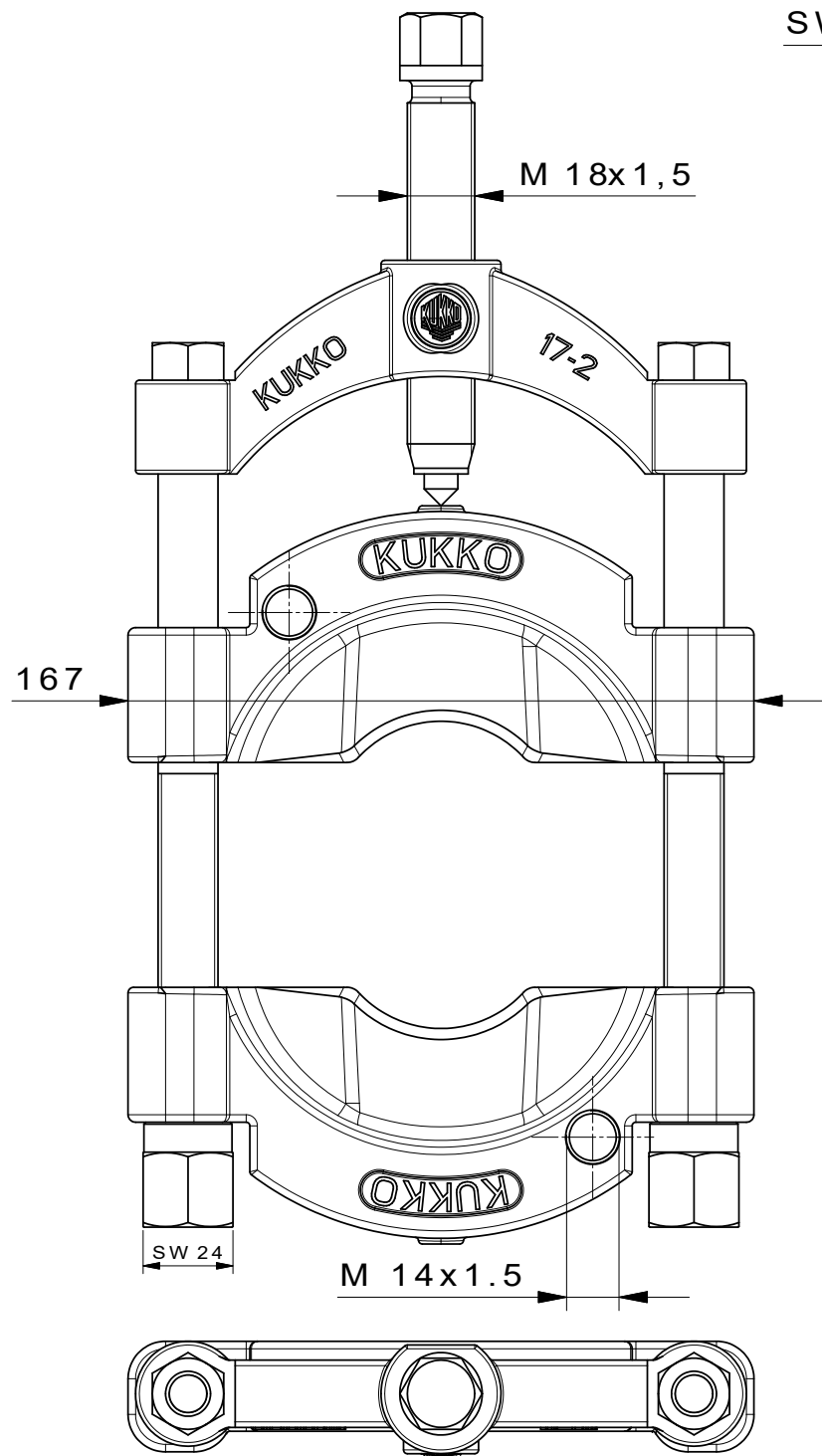

| | | |
|---|--|--|
|  Kleinbongartz & Kaiser oHG Werkzeugfabrik Hilden - Germany | Dokumentname: 17-2_Trennvorrichtung mit Spindel | Toleranz: DIN ISO 2768-m |
| | Dokumentbeschreibung: Baugruppe | Material: Hoch legierter Werkzeugstahl / High alloy tool steel |
| Erstellt von: Schultes | Erstellungsdatum: 08/04/2016 | Maßstab: 1:1 |
| Teilbeschreibung: Trennvorrichtung mit Schnellspanndruckspindel/ Separator with quick clamping pressure spindle | | Wärmebehandlung / Härte: vergüteter Stahl/ tempered steel |
| Artikelnummer / ZNR.: 17-2 | Dokumentversion: - | Schutzvermerk ISO 16616 beachten |