



Productnaam

Mestrekker met snelspanspindel





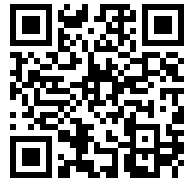

Voor het demonteren van lagers, binnenringen, en andere objecten, indien standaard trekhaken niet toereikend zijn

Art nr. 17-2

Serie 17

EAN 4021176008368



	Technisch kenmerk	Metrisch	Imperial
	Diameter van de schacht	22 - 115 mm	7/8 - 4 1/2 inch
	Afstand trekbouten	115 mm	4 1/2 inch
	Gewicht	3.72 kg	
	Ruimte beneden	0 mm	0 inch
	Raum nebendran	115 mm	4 1/2 inch
	Spanwijdte, uitwendig	22 - 22 mm	7/8 - 7/8 inch
	Spandiepte	250 mm	9 7/8 inch



heeft nog nodig

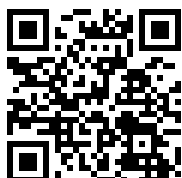

Hulptrekker

18-2



**Hydraulische hulptrekker
(inclusief mechanische
spindel)**

18-2-B



Onderdeel

Art nr.	Productnaam
618105	Mechanische spindels.
17-2-T	Brug
17-2-06	Spindel
017235	Zijbout met moer

Is onderdeel van

Art nr.	Productnaam
17-B	Mestrekker-set met snelspanspindel
WT-019	Trekkerassortiment -mestrekken
K-20+17-C	Universele trekkerset met mestrekker
K-20+17	Universele trekkerset met mestrekker
EVLW-INDUSTRIE BASIC	Verkoopwand, industrie-gereedschap



Is onderdeel van

Art nr.

Productnaam

17-B

Mestrekker-set met snelspanspindel

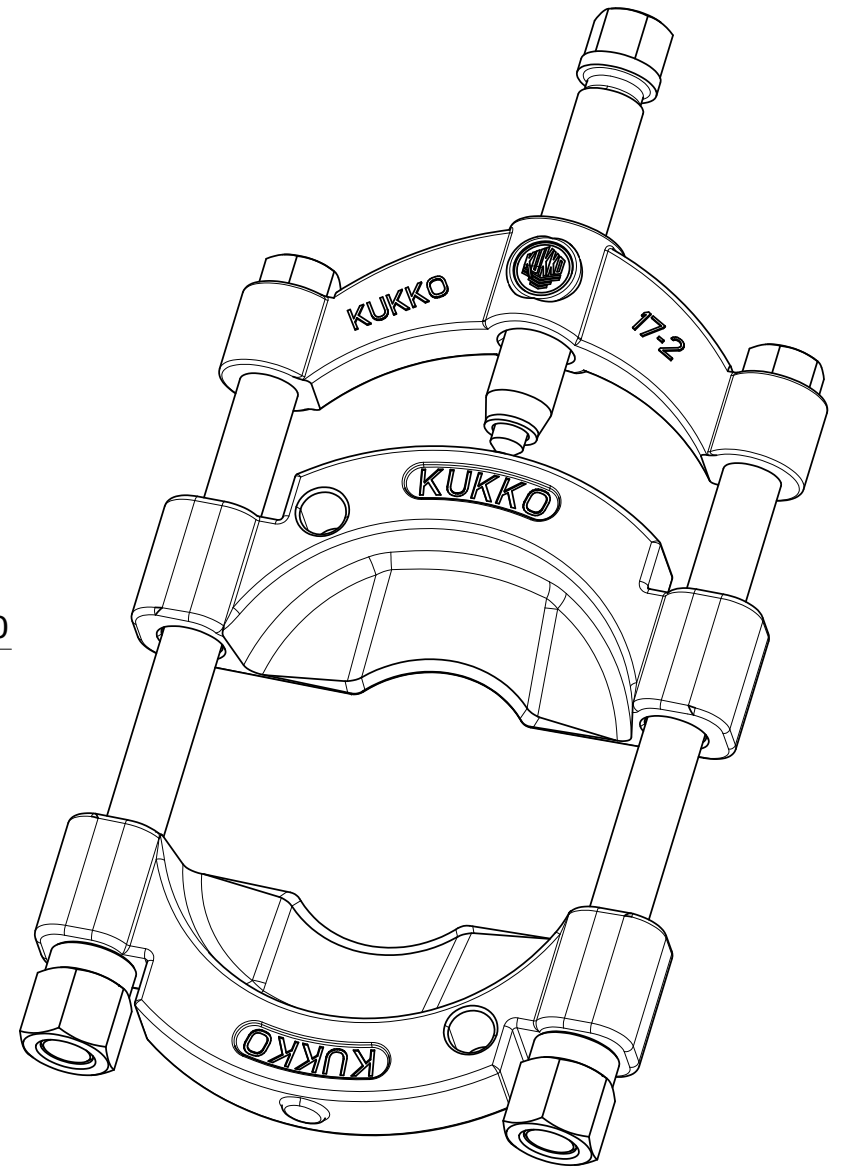
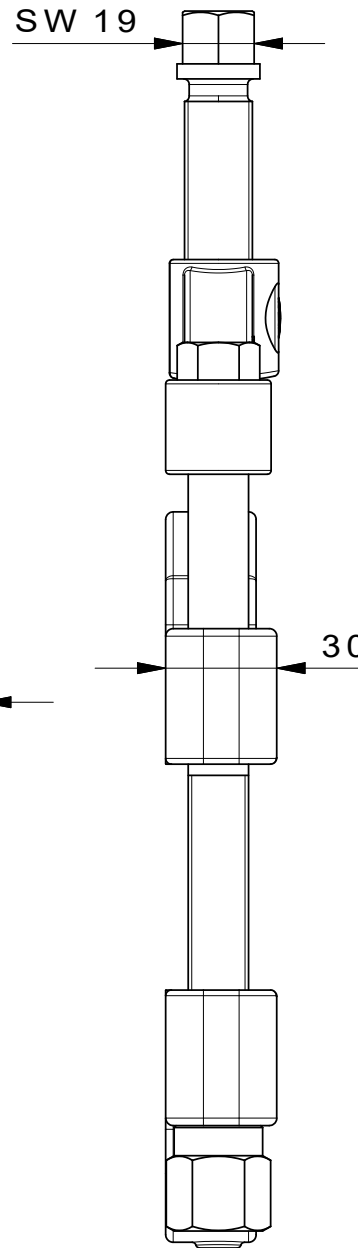
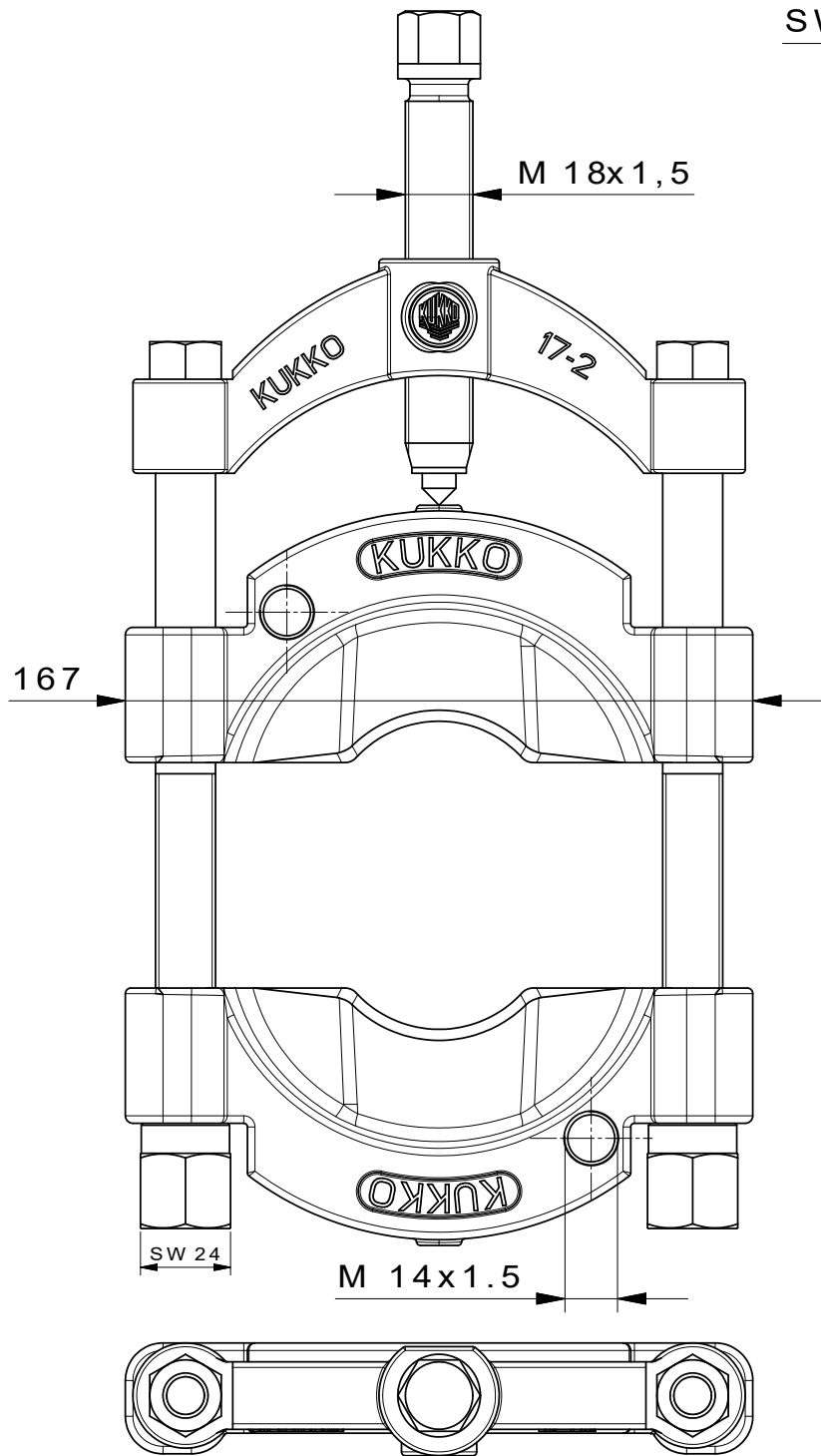

 Kleinbongartz & Kaiser oHG Werkzeugfabrik Hilden - Germany	Dokumentname: 17-2_Trennvorrichtung mit Spindel	Toleranz: DIN ISO 2768-m
	Dokumentbeschreibung: Baugruppe	Material: Hoch legierter Werkzeugstahl / High alloy tool steel
Erstellt von: Schultes	Erstellungsdatum: 08/04/2016	Maßstab: 1:1
Teilbeschreibung: Trennvorrichtung mit Schnellspanndruckspindel/ Separator with quick clamping pressure spindle		Wärmebehandlung / Härte: vergüteter Stahl/ tempered steel Oberflächenbehandlung:
Artikelnummer / ZNR: 17-2	Dokumentversion: -	Schutzvermerk ISO 16616 beachten