



Ürün adı

## Hızlı kenetlenen basınç miline sahip ayırma tertibatı

Çektirme kolları için yeterli yer olmadığında bilyeli yatakları, makaralı rulmanları, iç bilezikleri ve diğer gömülü oturan parçaları çıkarmak için.

Ürün No. 17-2

Seriler 17







EAN 4021176008368



### Teknik özellik

### Metrik

### Imparatorluk

	Teknik özellik	Metrik	Imparatorluk
	Şaft çapı	22 - 115 mm	7/8 - 4 1/2 inch
	Yan civataların mesafesi	115 mm	4 1/2 inch
	Ağırlık	3.72 kg	
	Raum unterhalb	0 mm	0 inch
	Raum nebendran	115 mm	4 1/2 inch
	Açılma genişliği	22 - 22 mm	7/8 - 7/8 inch
	Derinlik	250 mm	9 7/8 inch



...ile tamamlanması gerekir

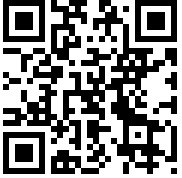

**Çektirme**  
18-2

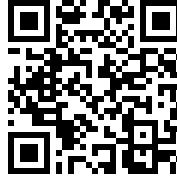

**Hidrolik çekme tertibatı**  
**(mekanik mil dahil)**  
18-2-B



## Yedek parça

Ürün No.	Ürün adı
618105	Mekanik mil
17-2-T	Gövde
17-2-06	Mil
017235	Somunlu yan civata

## Parçasıdır

Ürün No.	Ürün adı
17-B	Hızlı kenetlenen basınç miline sahip ayırma tertibatı seti
WT-019	Çektirme ürün yelpazesi - Ayırıcılar
K-20+17-C	Üniversal Ayırıcı ve Çektirme Seti
K-20+17	Üniversal Ayırıcı ve Çektirme Seti
EVLW-INDUSTRIE BASIC	Sanayi için satış panosu



## In yedek parçası

**Ürün No.**

**Ürün adı**

17-B

Hızlı kenetlenen basınç miline sahip ayırma tertibatı seti

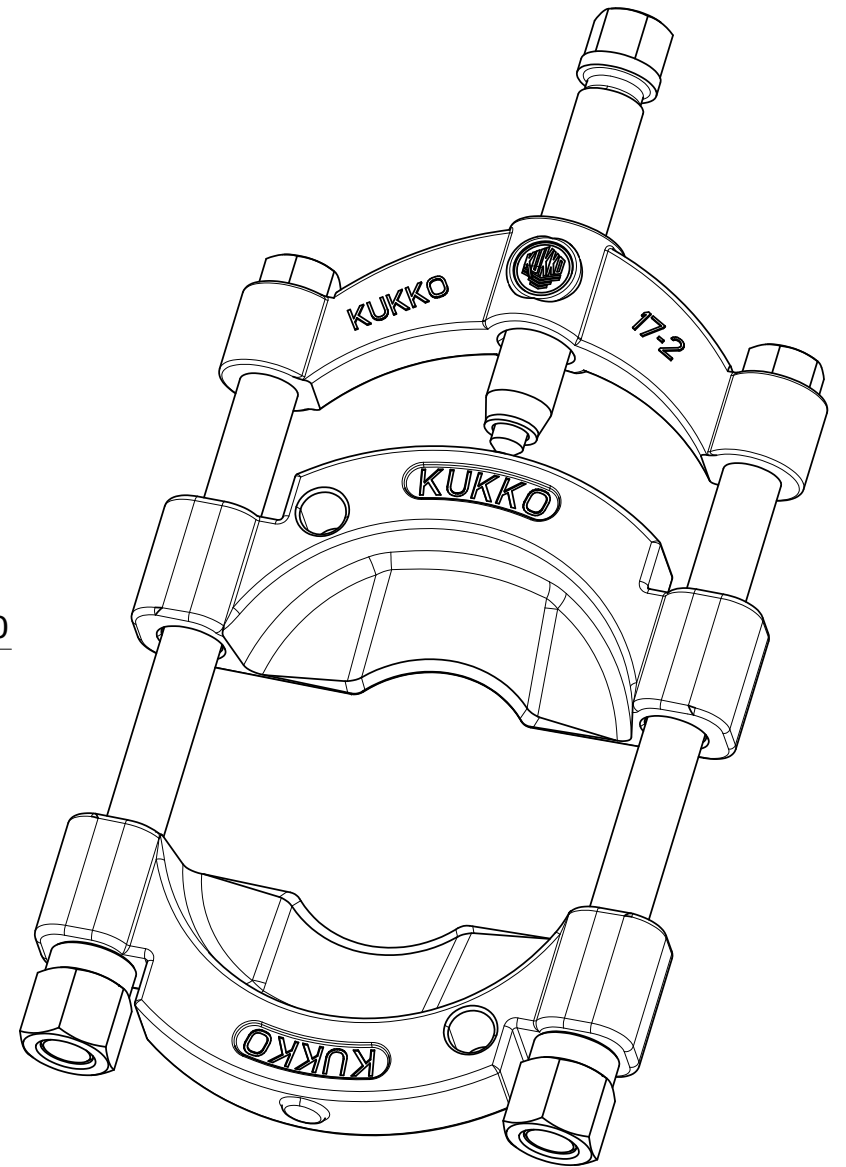
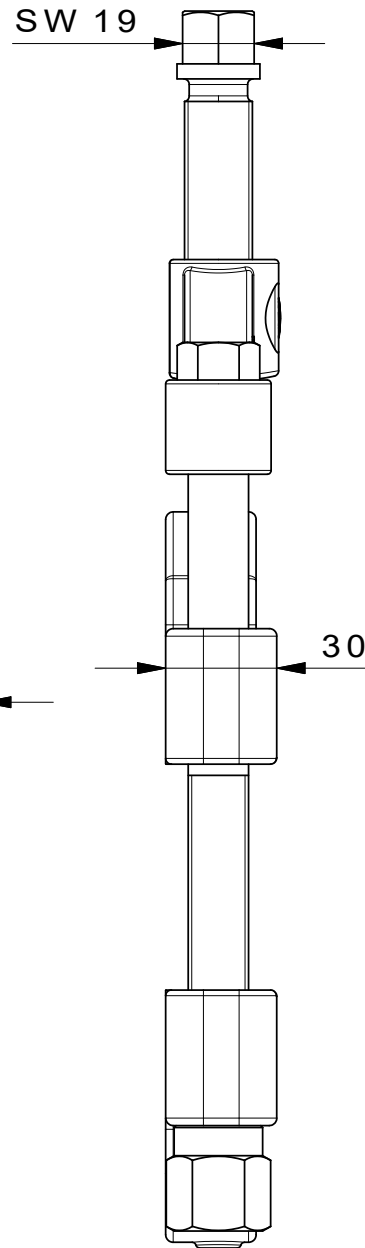
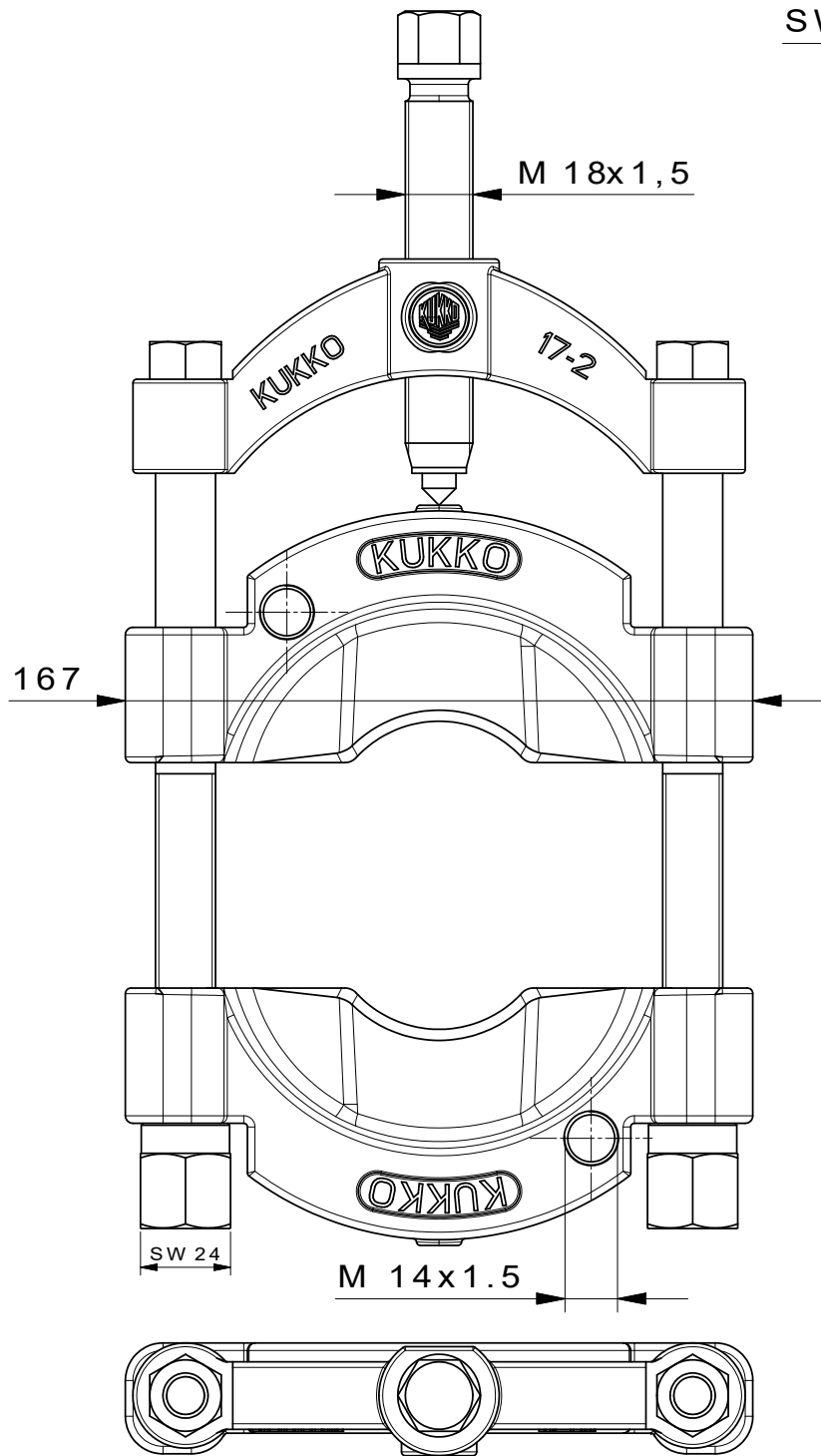

 <b>Kleinbongartz &amp; Kaiser oHG</b> Werkzeugfabrik Hilden - Germany	Dokumentname: 17-2_Trennvorrichtung mit Spindel	Toleranz: DIN ISO 2768-m
	Dokumentbeschreibung: Baugruppe	Material: Hoch legierter Werkzeugstahl / High alloy tool steel
Erstellt von: Schultes	Erstellungsdatum: 08/04/2016	Maßstab: 1:1
Teilbeschreibung: Trennvorrichtung mit Schnellspanndruckspindel/ Separator with quick clamping pressure spindle		Wärmebehandlung / Härte: vergüteter Stahl/ tempered steel Oberflächenbehandlung:
Artikelnummer / ZNR.: 17-2	Dokumentversion: -	Schutzvermerk ISO 16616 beachten