



Productnaam

Mestrekker met snelspanspindel





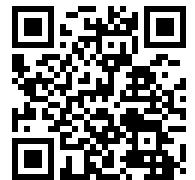

Voor het demonteren van lagers, binnenringen, en andere objecten, indien standaard trekhaken niet toereikend zijn

Art nr. 17-3

Serie 17

EAN 4021176008443



	Technisch kenmerk	Metrisch	Imperial
	Diameter van de schacht	25 - 155 mm	1 - 6 1/8 inch
	Afstand trekbouten	155 mm	6 1/8 inch
	Gewicht	7.135 kg	
	Ruimte beneden	0 mm	0 inch
	Raum nebendran	155 mm	6 1/8 inch
	Spanwijdte, uitwendig	25 - 25 mm	1 - 1 inch
	Spandiepte	300 mm	11 7/8 inch



heeft nog nodig

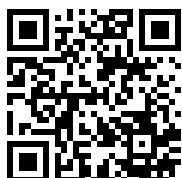

Hulptrekker

18-3

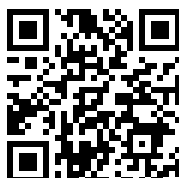

**Hydraulische hulptrekker
(inclusief mechanische
spindel)**

18-3-B



Onderdeel

Art nr.	Productnaam
17-3-T	Brug
17-3-06	Spindel
621170	Mechanische spindels.
017322	Zijbout met moer
621220	Mechanische spindels.

Is onderdeel van

Art nr.	Productnaam
17-C	Mestrekker-set met snelspanspindel

Is onderdeel van

Art nr.	Productnaam
17-C	Mestrekker-set met snelspanspindel

SW 22

G 1/2"

KUKKO

17-3

KUKKO

210

36

KUKKO

17-3

KUKKO

KUKKO

M 18x1.5

SW 32

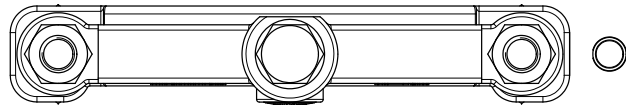
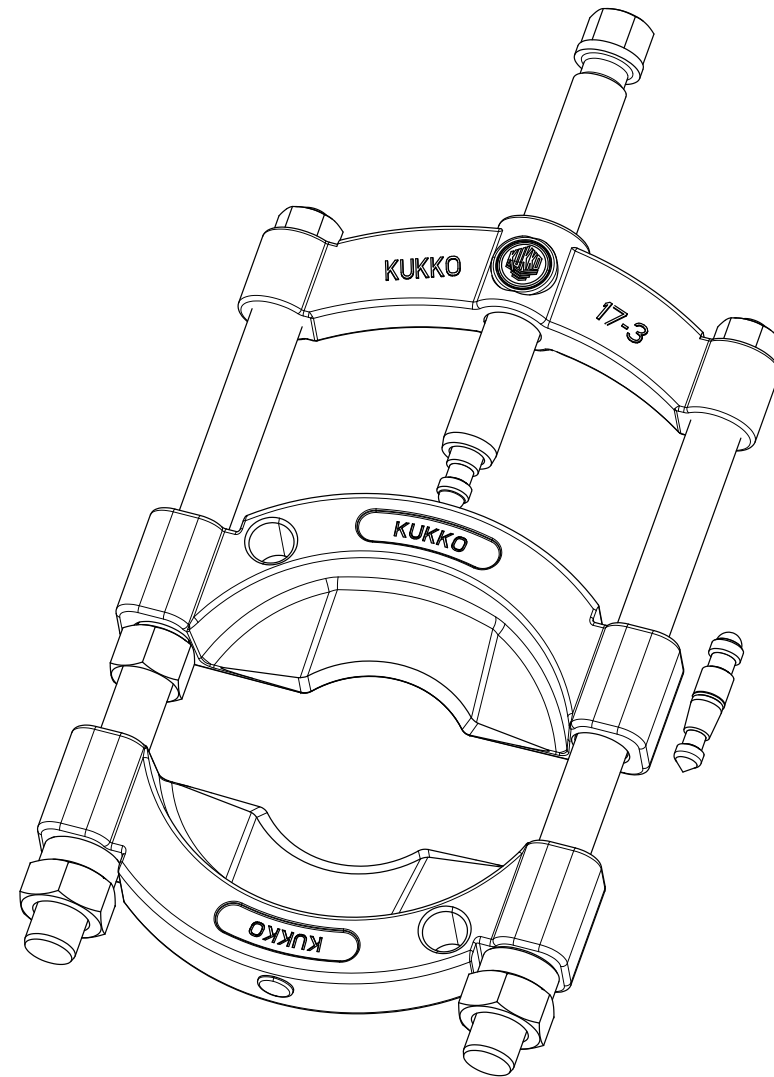

 Kleinbongartz & Kaiser oHG Werkzeugfabrik Hilden - Germany	Dokumentnr.: 17-3_Trennvorrichtung mit Spindel	Toleranz: DIN ISO 2768-m
	Dokumentbeschreibung: Baugruppe	Material: Hoch legierter Werkzeugstahl / High alloy tool steel
Erweit. von: Schultes	Erstellungsdatum: 12/04/2016	Maßstab: 1:1
Teilbeschreibung: Trennvorrichtung mit Schnellspanndruckspindel / Separator with quick clamping pressure spindle	Wärmebehandlung / Härte: vergüteter Stahl / tempered steel	Oberflächenbehandlung:
Artikelnummer / ZNR.: 17-3	Dokumentversion: -	Schutzvermerk: ISO 16949 zertifiziert