



Productnaam *

Hulptrekker





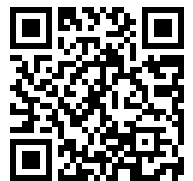

in combinatie te gebruiken met Baureihe 17,
Baureihe 15, Baureihe 18-AS en Baureihe 18-A.

Art nr. 18-0

Serie 18

EAN 4021176075599



	Technisch kenmerk	Metrisch	Imperial
	Breedte trekbout	50 - 110 mm	2 - 4 3/8 inch
	Diepte trekbout	71 - 150 mm	2 3/4 - 5 7/8 inch
	Schroefdraad	M10	M10
	Buitenzeskant	13 mm	
max.	Maximaal toegestane belasting	3 t	3 US t
	Max. aandraaimoment	40 Nm	29.5 ft lb
	Gewicht	0.825 kg	



Technologieën



SWITCH

Optimale aanpassing van de spil aan de as dankzij de dubbele spilkop.



Onderdeel

Art nr.	Productnaam
612130	Mechanische spindels.
18-0-T	Brug
018175	Zijbout met moer

Toebehoren

Art nr.	Productnaam
18-0-AS	Schroefdraadadapters-set
18-003A	Schroefdraadadapters
18-004A	Schroefdraadadapters
18-005A	Schroefdraadadapters
18-006A	Schroefdraadadapters
18-008A	Schroefdraadadapters
18-010A	Schroefdraadadapters
18-012A	Schroefdraadadapters
18-016A	Schroefdraadadapters
19-1-P	2 verlengstukken voor hulptrekker (paar)
K-600-014	Wisseldrukstukken set voor KUKKO spindels



Gaat met

Art nr.	Productnaam
15-0	Mestrekkers
17-0	Mestrekker met snelspanspindel

Is onderdeel van

Art nr.	Productnaam
15-K	Mestrekker-set
17-K	Mestrekker-set met snelspanspindel
EVLW-2-INDUSTRIE	Verkoopwand, industrie-gereedschap
WT-1-INDUSTRIE	Trekkerassortiment - Industrie
WT-100+C	Trekkerassortiment -buitentrekken- Basis+
EVLW-INDUSTRIE BASIC	Verkoopwand, industrie-gereedschap

Is onderdeel van

Art nr.	Productnaam
15-K	Mestrekker-set
17-K	Mestrekker-set met snelspanspindel

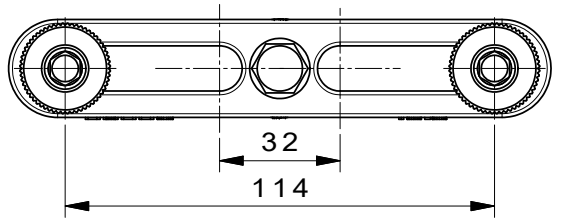
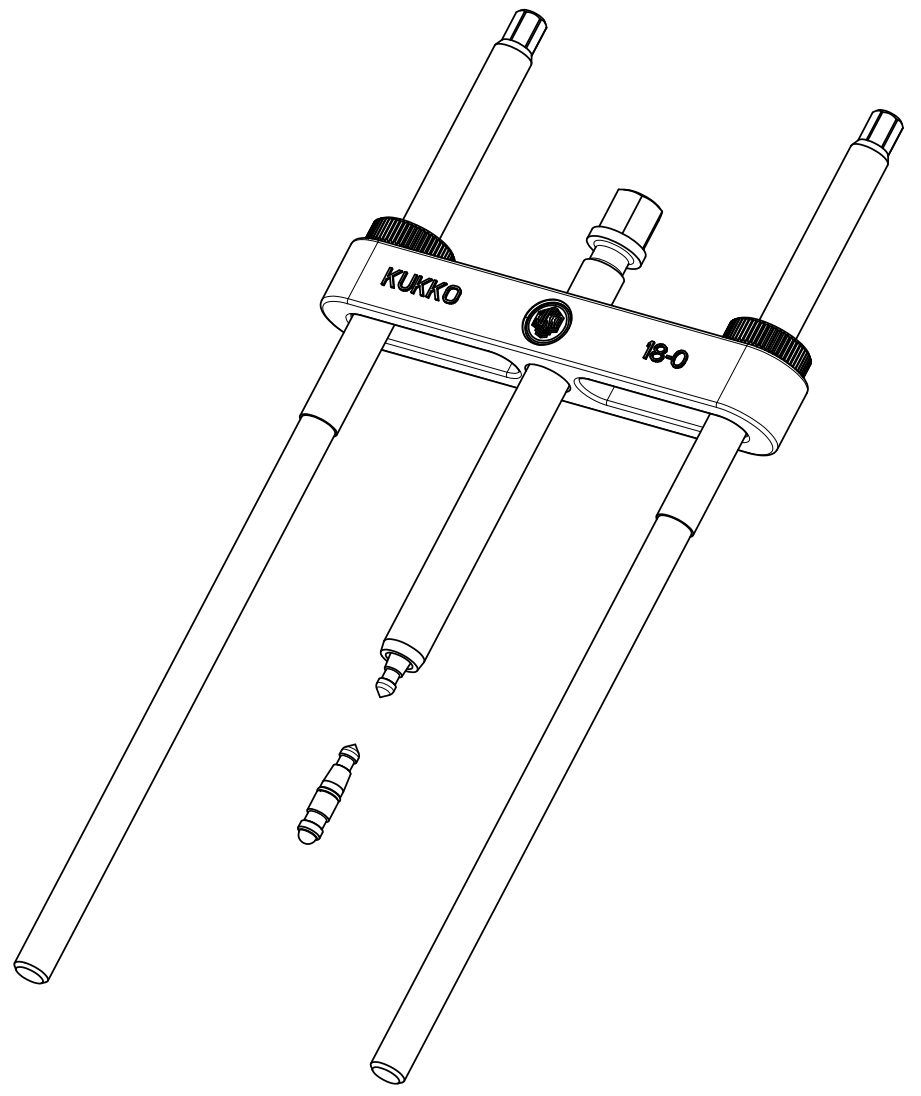
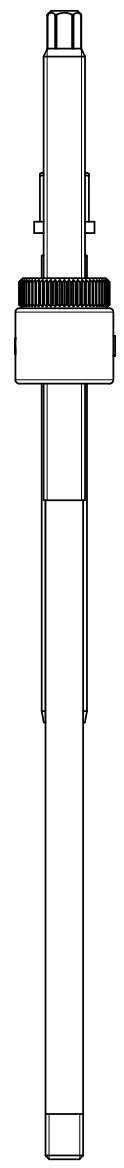
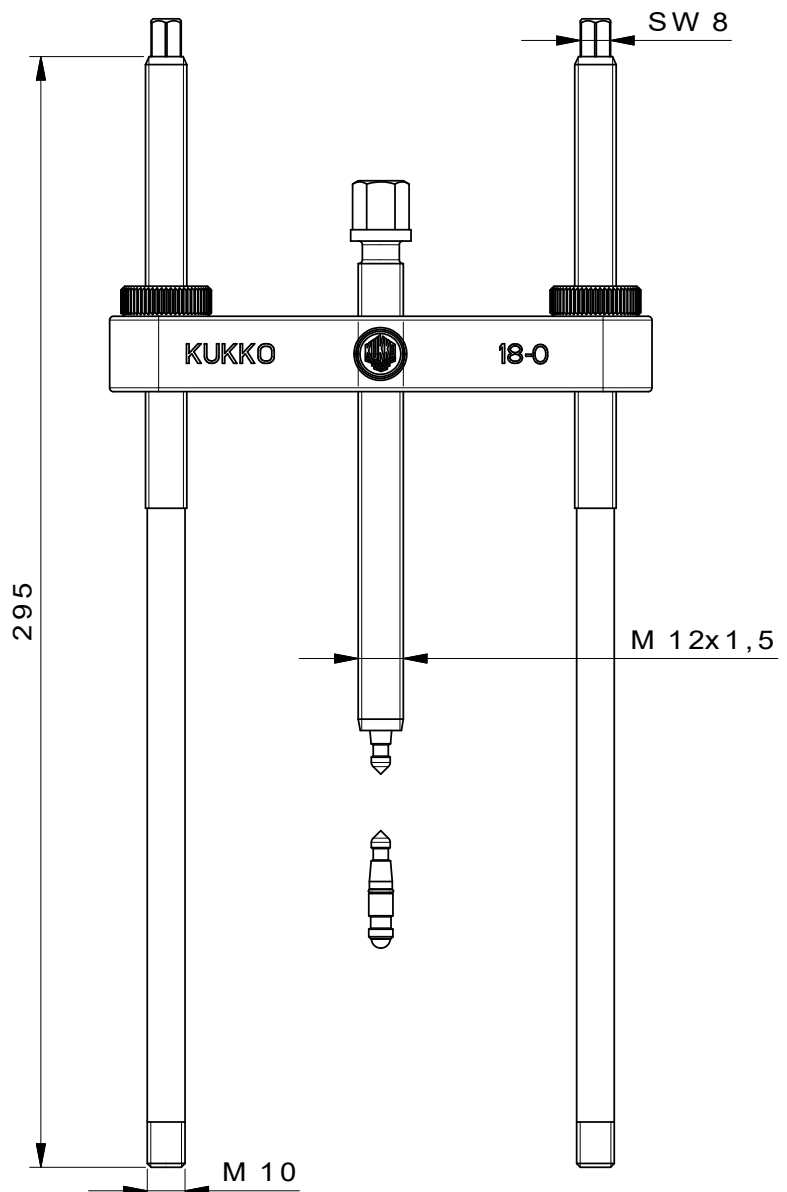

 Kleinbongartz & Kaiser oHG Werkzeugfabrik Hilden - Germany	Dokumentname: 18-0 Abziehvorrichtung	Toleranz: DIN ISO 2768-m
	Dokumentbeschreibung: Baugruppe	Material: Hoch legierter Werkzeugstahl / High alloy tool steel
Erstellt von: Schultes	Erstellungsdatum: 12/04/2016	Maßstab: 1:1
Teilbeschreibung: Abziehvorrichtung / Pulling device		Wärmebehandlung / Härte: Oberflächenbehandlung:
Artikelnummer / ZNR.: 18-0	Dokumentversion: -	Schutzvermerk ISO 16016 beachten