



Product name \*

## Pulling device

For use with series 17, series 15, series 18-AS and series 18-A.

Art. No. 18-2

Series 18

EAN 4021176075759

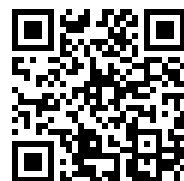

	Technical attribute	Metric	Imperial
	Distance of side screw	68 - 244 mm	2 3/4 - 9 5/8 inch
	Depth of side screw	145 - 280 mm	5 3/4 - 11 1/32 inch
	Thread	M14x1,5	M14x1,5
	Hexagon drive (male)	22 mm	
max.	Maximum load	7 t	7.5 US t
max.	Maximum torque	120 Nm	88.5 ft lb
	Weight	3.245 kg	



## Technologies



### **SWITCH**

A two-sided spindle tip provides optimal adjustment of the spindle to the shaft.



## Spare part

<b>Art. No.</b>	<b>Product name</b>
18-2-T	Cross-beam
621170	Mechanical pressure spindle.
018275	Side bolt with nut

## Accessories

<b>Art. No.</b>	<b>Product name</b>
8-01	Long hydraulic spindle
19-2-P	2 extensions for pulling devices (pair)
18-2-AS	Set of screw adapters
18-208A	Threaded adapter
18-210A	Threaded adapter
18-212A	Threaded adapter
18-214A	Threaded adapter
18-216A	Threaded adapter
18-218A	Threaded adapter
K-600-025	Set of interchangeable pressure pads for KUKKO pressure screws



## Goes with

<b>Art. No.</b>	<b>Product name</b>
15-2	Separators
17-2	Separator with quick clamping pressure spindle

## Part of

<b>Art. No.</b>	<b>Product name</b>
WT-010	Puller product range - commercial vehicles - TOP
15-B	Separating-set
17-B	Separating-set with quick clamping pressure spindle
WT-50	Puller product range - industrial - TOP
K-20-15	Universal puller set with separator
29-B	Universal puller set in TANOS-Systainer®
WT-019	Puller product range - separating
EVLW-INDUSTRIE BASIC	Display





## Spare part of

<b>Art. No.</b>	<b>Product name</b>
15-B	Separating-set
17-B	Separating-set with quick clamping pressure spindle
K-20-15	Universal puller set with separator
29-B	Universal puller set in TANOS-Systainer®

## Also included in

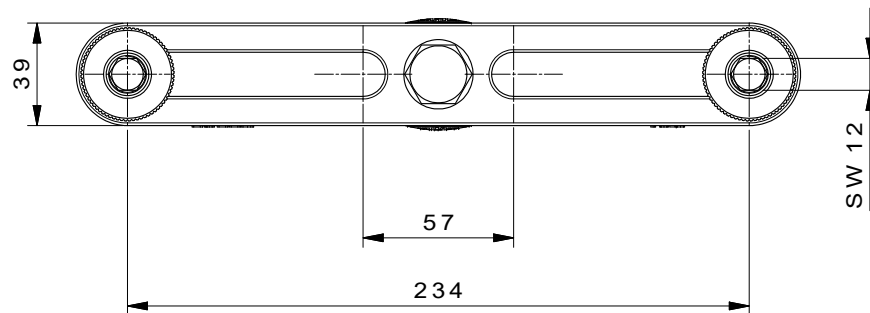
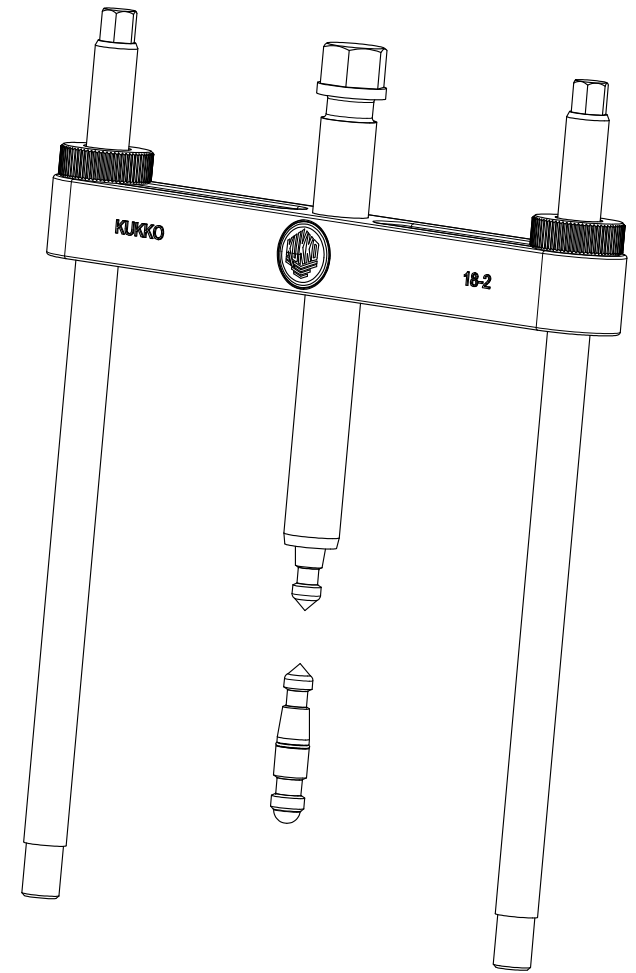
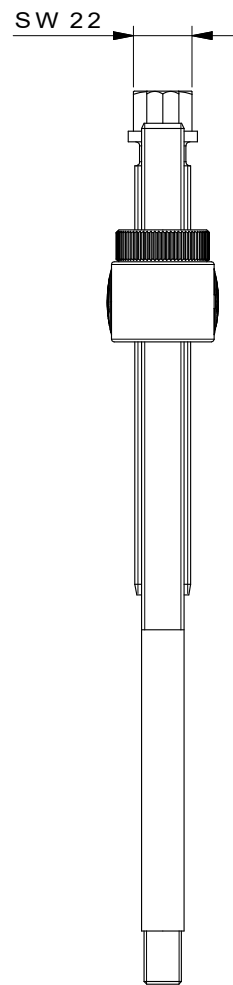
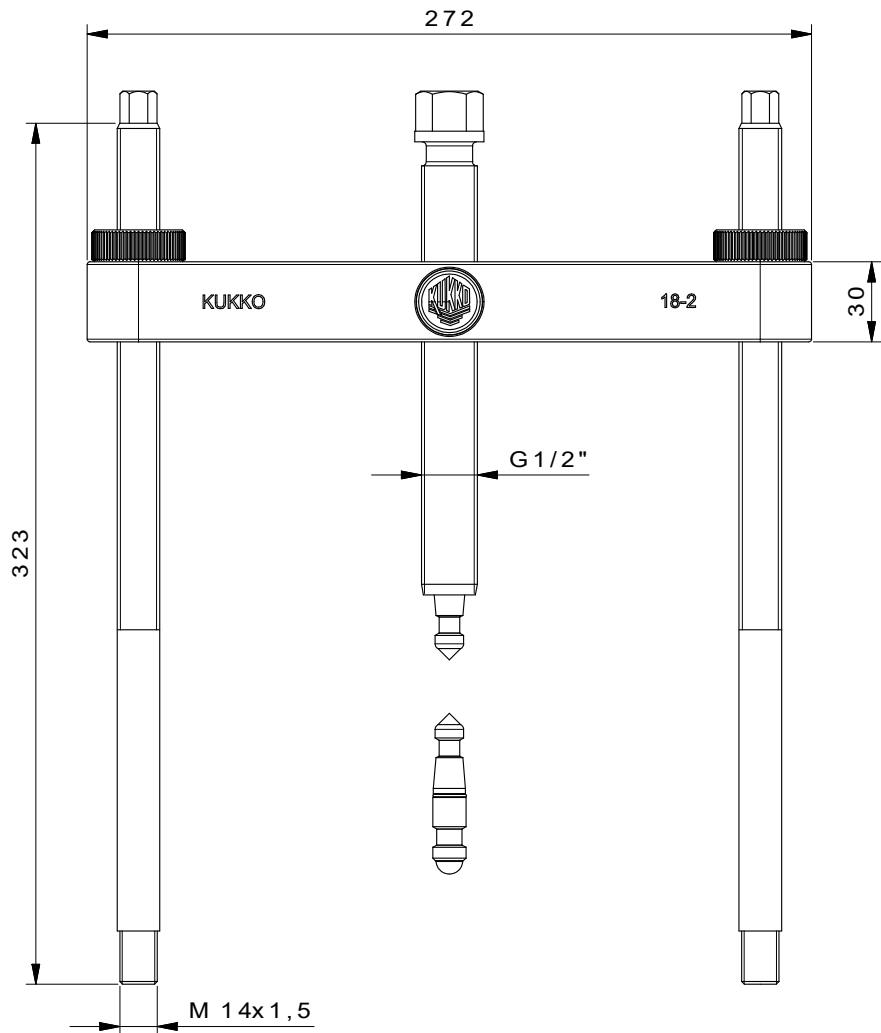
<b>Art. No.</b>	<b>Product name</b>
WT-010	Puller product range - commercial vehicles - TOP
WT-50	Puller product range - industrial - TOP
K-20-15	Universal puller set with separator



 <b>Kleinbongartz &amp; Kaiser oHG</b> <b>Werkzeugfabrik Hilden - Germany</b>	Dokumentname: <b>18-2 Abziehvorrichtung</b>	Teilname: <b>DIN ISO 2768-m</b>
	Dokumentbeschreibung: <b>Baugruppe</b>	Material: Hoch legierter Werkzeugstahl / High alloy tool steel
Teilbestellung: <b>Abziehvorrichtung / Pulling device</b>	Erweit. von: Schultes	Sicherheitsdatum: 12/04/2016
Artikelnummer / Znr.: <b>18-2</b>	Dokumentversion: -	Schutzvermerk: ISO 16949 zertifiziert
Wärmebehandlung / Heat:		Oberflächenbehandlung: