



Productnaam *

Hulptrekker





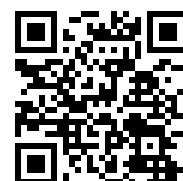

in combinatie te gebruiken met Baureihe 17,
Baureihe 15, Baureihe 18-AS en Baureihe 18-A.

Art nr. 18-2

Serie 18

EAN 4021176075759



	Technisch kenmerk	Metrisch	Imperial
	Breedte trekbout	68 - 244 mm	2 3/4 - 9 5/8 inch
	Diepte trekbout	145 - 280 mm	5 3/4 - 11 1/32 inch
	Schroefdraad	M14x1,5	M14x1,5
	Buitenzeskant	22 mm	
max.	Maximaal toegestane belasting	7 t	7.5 US t
	Max. aandraaimoment	120 Nm	88.5 ft lb
	Gewicht	3.245 kg	



Technologieën



SWITCH

Optimale aanpassing van de spil aan de as dankzij de dubbele spilkop.



Onderdeel

Art nr.	Productnaam
18-2-T	Brug
621170	Mechanische spindels.
018275	Zijbout met moer

Toebehoren

Art nr.	Productnaam
8-01	Lange hydraulische spindel
19-2-P	2 verlengstukken voor hulptrekker (paar)
18-2-AS	Schroefdraadadapters-set
18-208A	Schroefdraadadapters
18-210A	Schroefdraadadapters
18-212A	Schroefdraadadapters
18-214A	Schroefdraadadapters
18-216A	Schroefdraadadapters
18-218A	Schroefdraadadapters
K-600-025	Wisseldrukstukkenet voor KUKKO spindels



Gaat met

Art nr.	Productnaam
15-2	Mestrekkers
17-2	Mestrekker met snelspanspindel

Is onderdeel van

Art nr.	Productnaam
WT-010	Trekkerassortiment -automotive NFZ - TOP
15-B	Mestrekker-set
17-B	Mestrekker-set met snelspanspindel
WT-50	Trekkerassortiment - Industrie - TOP
K-20-15	Universeel trekker en mestrekker set
29-B	Universeel trekker-set in TANOS-Systainer®
WT-019	Trekkerassortiment -mestrekken
EVLW-INDUSTRIE BASIC	Verkoopwand, industrie-gereedschap



Is onderdeel van

Art nr.	Productnaam
15-B	Mestrekker-set
17-B	Mestrekker-set met snelspanspindel
K-20-15	Universeel trekker en mestrekker set
29-B	Universeel trekker-set in TANOS-Systainer®

Zit ook in

Art nr.	Productnaam
WT-010	Trekkerassortiment -automotive NFZ - TOP
WT-50	Trekkerassortiment - Industrie - TOP
K-20-15	Universeel trekker en mestrekker set

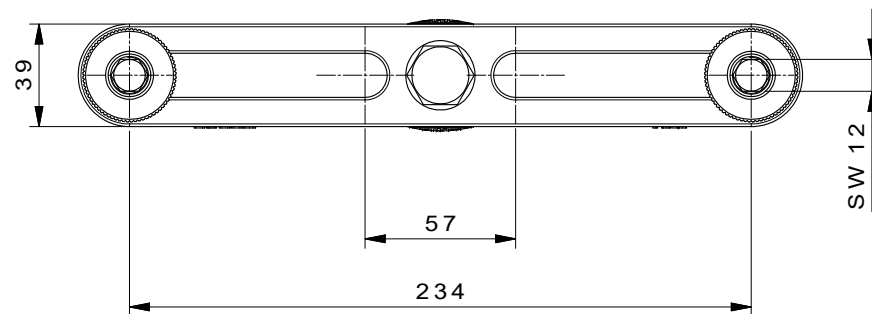
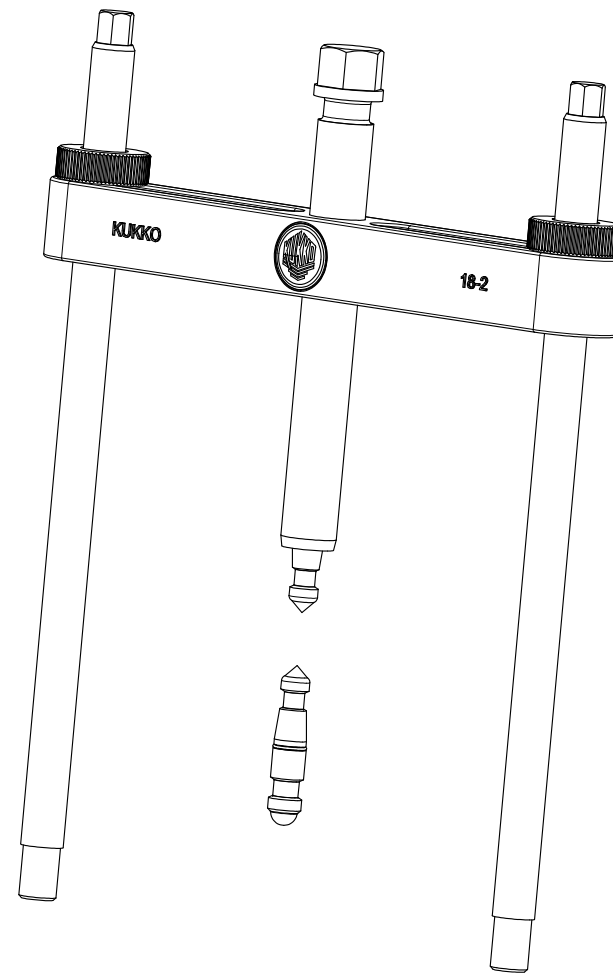
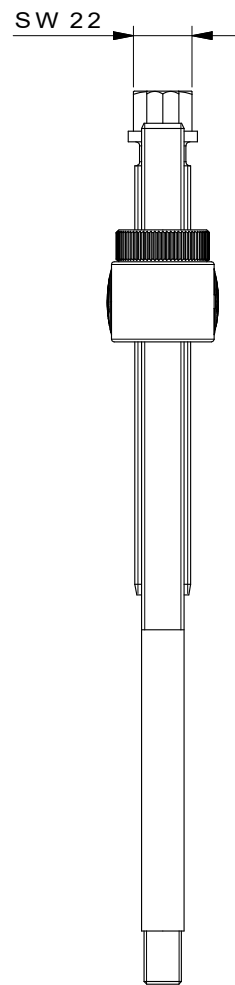
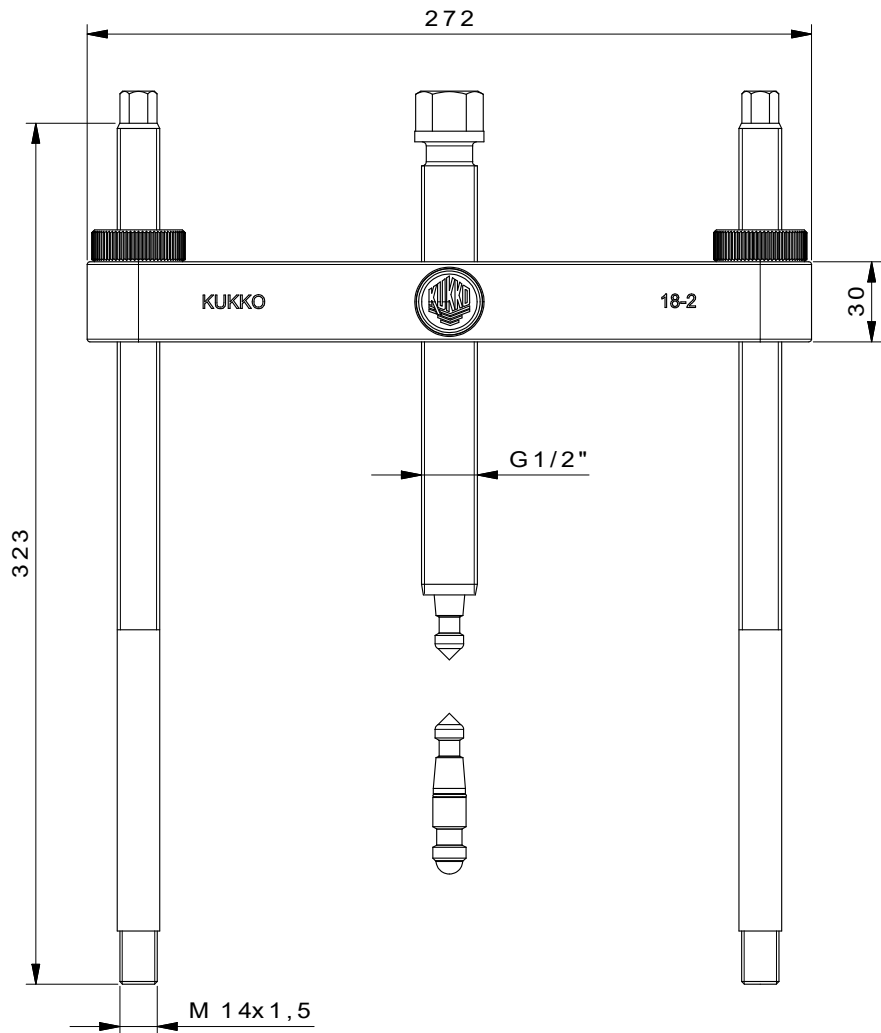

 Kleinbongartz & Kaiser oHG Werkzeugfabrik Hilden - Germany	Dokumentname: 18-2 Abziehvorrichtung	Teilenummer: DIN ISO 2768-m
	Dokumentbeschreibung: Baugruppe	Material: Hoch legierter Werkzeugstahl / High alloy tool steel
Erstellt von: Schultes	Sicherheitsdatum: 12/04/2016	Maßstab: 1:1
Teilbeschreibung: Abziehvorrichtung / Pulling device	Wärmebehandlung / Heat: -	Oberflächenbehandlung: -
Artikelnummer / Znr.: 18-2	Dokumentversion: -	Schutzvermerk: ISO 16949 zertifiziert