



Nome do produto

Extrator universal de 2 braços com gancho de extração de ajuste rápido



Para remover rolamentos, engrenagens, discos, etc.

Artigo Nº 20-10+C

Série 20+C

EAN 4021176039720



	Características	Métrico	Polegada
	Extensão externa	30 - 120 mm	1 3/16 - 4 3/4 inch
	Profundidade de fixação	100 mm	3 7/8 inch
	Extensão interna	70 - 180 mm	2 3/4 - 7 1/8 inch
	Hexágono externo	17 mm	
max.	Carga máxima permitida	4,5 t	4.5 US t
	Binário máx.	80 Nm	59 ft lb
	Peso	1.48 kg	
	Número de ganchos	2	2
	Quarto abaixo	10 mm	3/8 inch
	Quarto de drenagem secundária	31 mm	1 1/4 inch



Tecnologias



GLIDE & FIX

A geometria otimizada garante um deslocamento suave e rápido das garras de extração na viga transversal.



ARMLOCK

Os mordentes cruzados garantem estabilidade máxima para a suspensão das garras de extração no carreto.



QUICK ADJUST

As serrilhas permitem a libertação rápida e sem ferramentas ou o deslocamento das garras de extração na viga transversal.



SWITCH

Ajuste ótimo do fuso ao eixo graças à ponta do fuso de duas faces.



Peça de substituição

Artigo Nº	Nome do produto
1-92-P-C	2 ganchos de extração de ajuste rápido (par)

Faz parte de

Artigo Nº	Nome do produto
20-ST+C	Expositor comercial para extratores de 2 braços
WT-100+C	Gama de extratores – Extratores – BASIC+

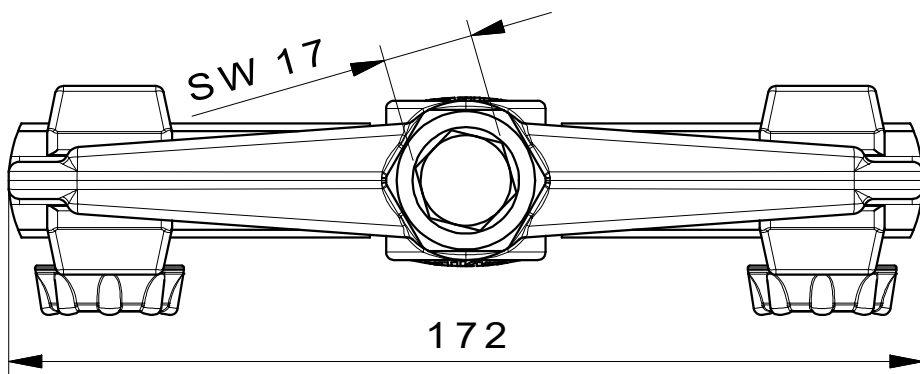
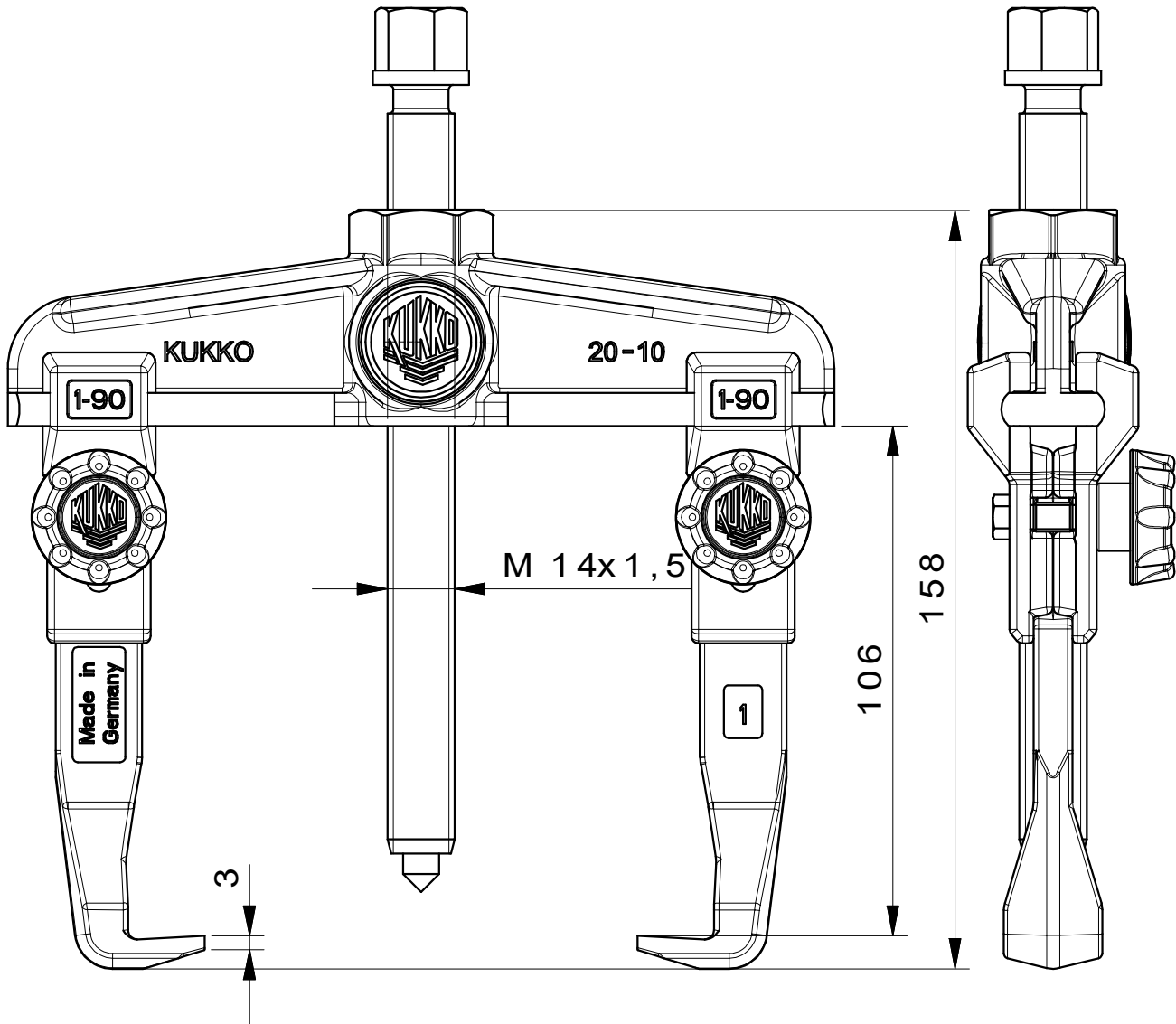
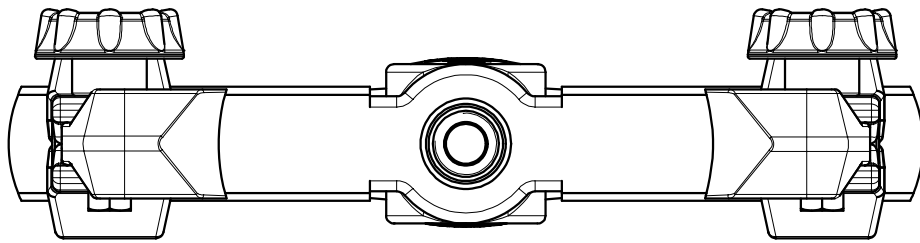

 Kleinbongartz & Kaiser oHG Werkzeugfabrik Hilden - Germany	Dokumentname: 20-10+C_2-Arm-Universal_Abzieher	Toleranz: DIN ISO 2768-m
	Dokumentbeschreibung: Baugruppe	Material: Hoch legierter Werkzeugstahl / High alloy tool steel
Erstellt / Geprüft von: Schultes	Erstellungsdatum: 30/03/2015	Maßstab: 1:1
Teilbeschreibung: 2-Arm-Universal_Abzieher/ 2-jaw puller		Wärmebehandlung / Härte: vergüteter Stahl/ tempered steel
Oberflächenbehandlung:		Schutzvermerk ISO 16016 beachten
Artikelnummer / ZNR.: 20-10+C	Dokumentversion: -	