



Ürün adı

## Hızlı ayarlanabilir çektirme kollarına sahip 2 kollu universal çektirme





Yatakları, dişlileri, rondelaları vb. çıkarmak için.

Ürün No. 20-10+C

Seriler 20+C

EAN 4021176039720



	<b>Teknik özellik</b>	<b>Metrik</b>	<b>Imparatorluk</b>
	Açılma genişliği	30 - 120 mm	1 3/16 - 4 3/4 inch
	Derinlik	100 mm	3 7/8 inch
	İç çektirme açılma genişliği	70 - 180 mm	2 3/4 - 7 1/8 inch
	Altıköşe geçme (erkek)	17 mm	
max.	İzin verilen maksimum yük	4,5 t	4.5 US t
	Maks. tork	80 Nm	59 ft lb
	Ağırlık	1.48 kg	
	Çene sayısı	2	2
	Raum unterhalb	10 mm	3/8 inch
	Raum nebendran	31 mm	1 1/4 inch



## Teknolojiler



### GLIDE & FIX

Optimal geometri çenenin giriş üzerinde kolayca ve hızlı kaydırılmasına izin verir.



### ARMLOCK

Çapraz kancalar çenenin kayar parça içine asılmasında azami denge sağlar.



### QUICK ADJUST

Çentikler çenelerin giriş üzerinde aletsiz ve hızlı serbest bırakılmasına ya da hareketine izin verir.



### SWITCH

İki taraflı mil ucu sayesinde milin şaftla optimum uyumu.



## Yedek parça

Ürün No.	Ürün adı
1-92-P-C	2 hızlı ayarlanabilir çekirme kolu (çift)

## Parçasıdır

Ürün No.	Ürün adı
20-ST+C	2 kollu çekirme için satışa uygun pano
WT-100+C	Çekirme ürün yelpazesi - Dış çekirme - BASIC+

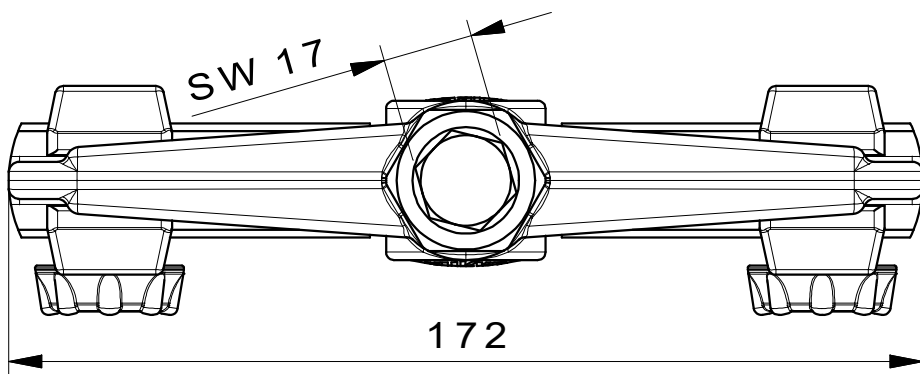
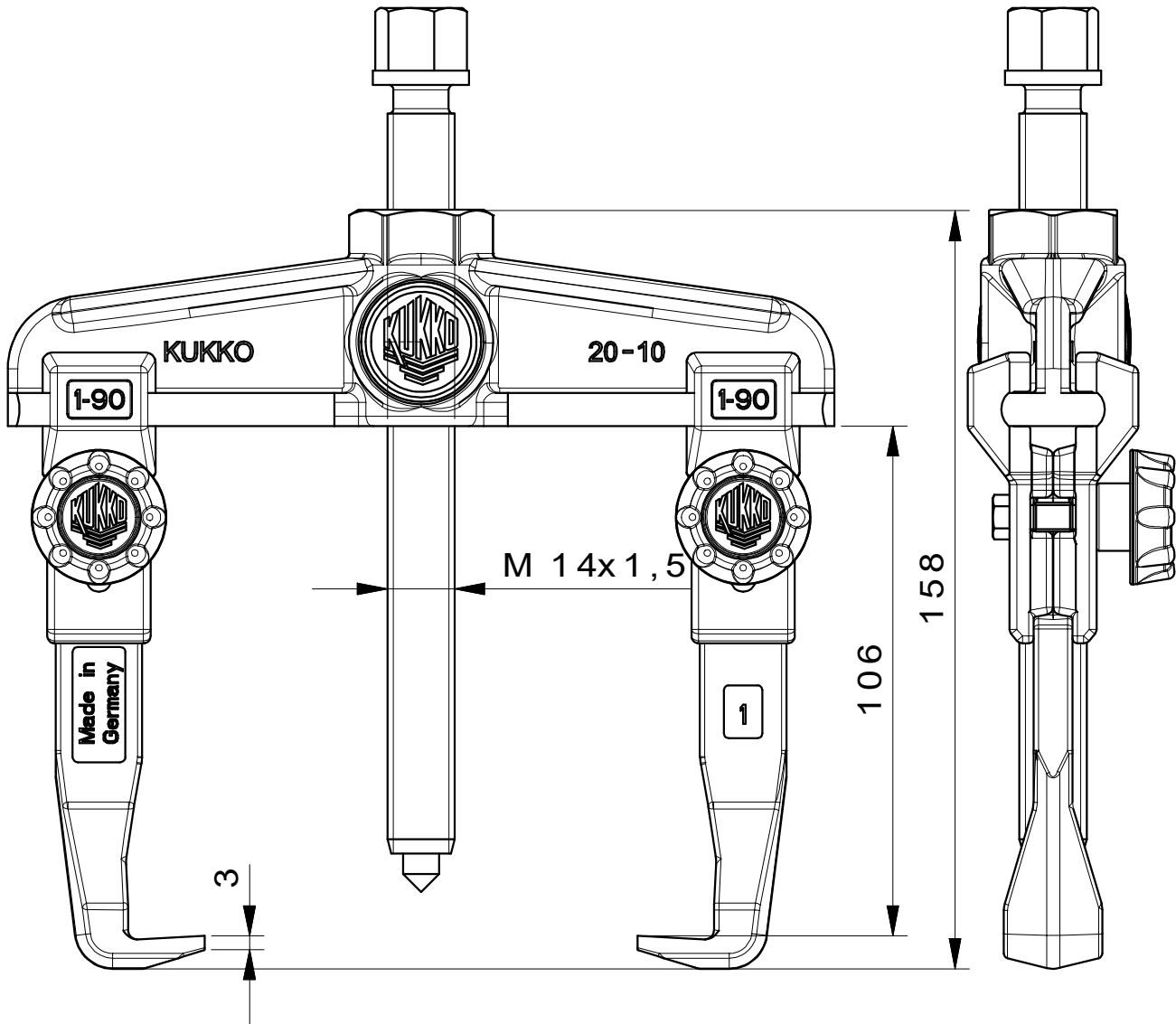
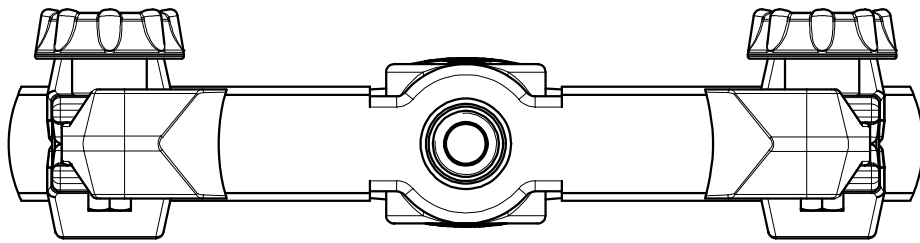

 <b>Kleinbongartz &amp; Kaiser oHG</b> Werkzeugfabrik Hilden - Germany	Dokumentname: 20-10+C_2-Arm-Universal_Abzieher	Toleranz: DIN ISO 2768-m
	Dokumentbeschreibung: Baugruppe	Material: Hoch legierter Werkzeugstahl / High alloy tool steel
Erstellt / Geprüft von: Schultes	Erstellungsdatum: 30/03/2015	Maßstab: 1:1
Teilbeschreibung: 2-Arm-Universal_Abzieher/ 2-jaw puller		Wärmebehandlung / Härte: vergüteter Stahl/ tempered steel
Oberflächenbehandlung:		Schutzvermerk ISO 16016 beachten
Artikelnummer / ZNR.: 20-10+C	Dokumentversion: -	