



产品名称

通用两爪拉马带快速调节拉马爪











用于拆卸轴承、齿轮、圆盘等。

编号 20-10+C

系列 20+C

EAN 4021176039720



技术规格	公制	英制
 跨度	30 - 120 mm	1 3/16 - 4 3/4 inch
 深度	100 mm	3 7/8 inch
 内部使用扩展	70 - 180 mm	2 3/4 - 7 1/8 inch
 六角驱动 (公)	17 mm	
 max. 最大负载	4,5 t	4.5 US t
 max. 最大扭矩	80 Nm	59 ft lb
 重量	1.48 kg	
 x 拉马爪数量	2	2
 下方空间	10 mm	3/8 inch
 邻近空间	31 mm	1 1/4 inch



技术



滑动&固定

优化的几何形状保证拉马爪能在横梁上轻松快速移动。



臂锁

十字爪最大程度地保证了滑块中拉马爪悬挂的稳定性。



快速调整

通过滚花螺栓可以不用工具就能快速释放或移动横梁上的拉马爪。



开关

通过两边的轴尖来调整优化主轴的位置。



配件

编号	产品名称
1-92-P-C	两只快速调节拉马爪 (对)

部分

编号	产品名称
20-ST+C	2爪拉马展示架
WT-100+C	拉马产品系列 - 外拉- 基础 +

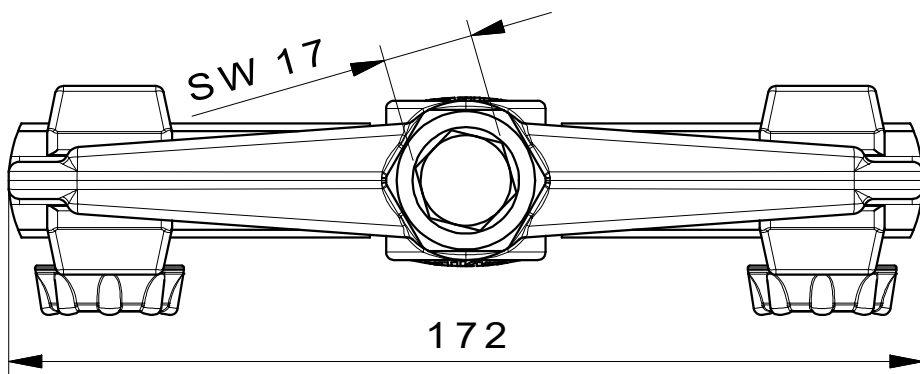
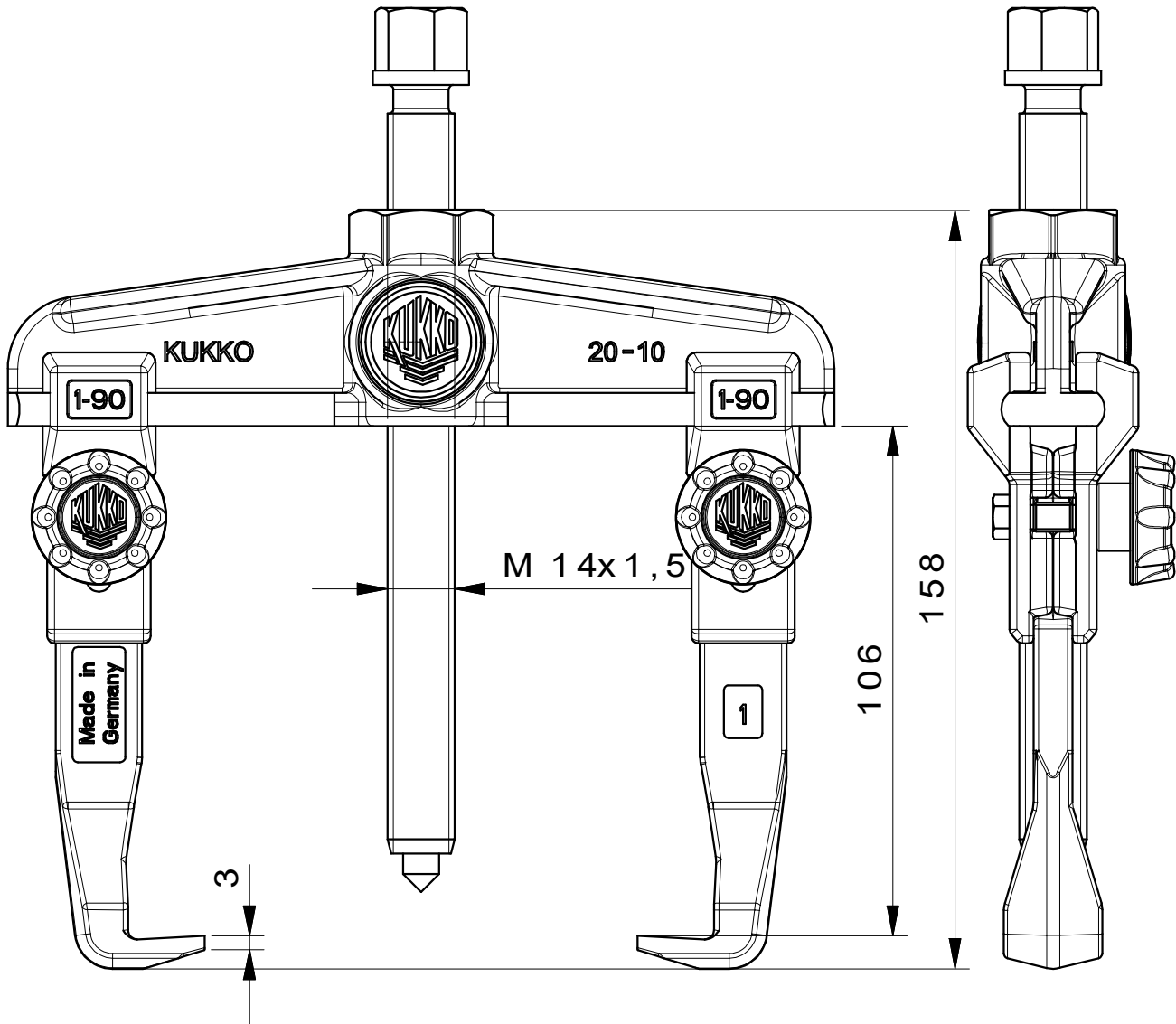
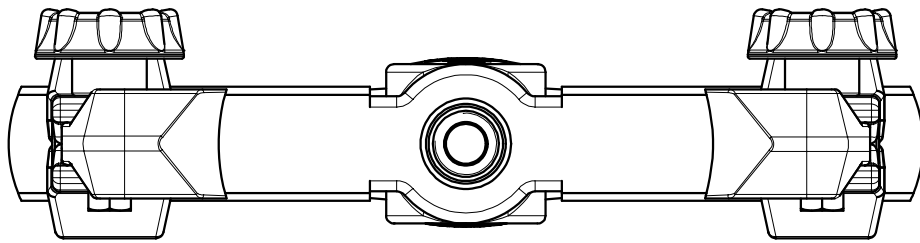

 Kleinbongartz & Kaiser oHG Werkzeugfabrik Hilden - Germany	Dokumentname: 20-10+C_2-Arm-Universal_Abzieher	Toleranz: DIN ISO 2768-m
	Dokumentbeschreibung: Baugruppe	Material: Hoch legierter Werkzeugstahl / High alloy tool steel
Erstellt / Geprüft von: Schultes	Erstellungsdatum: 30/03/2015	Maßstab: 1:1
Teilbeschreibung: 2-Arm-Universal_Abzieher/ 2-jaw puller		Wärmebehandlung / Härte: vergüteter Stahl/ tempered steel
Oberflächenbehandlung:		Schutzvermerk ISO 16016 beachten
Artikelnummer / ZNR.: 20-10+C	Dokumentversion: -	