



Ürün adı

Çok dar, hızlı ayarlanabilir çekme koluna sahip 2 kollu universal çekme





Aşırı dar ve erişilmesi zor alanlarda şanzıman dişlilerinin, yatakların, pinyonların ve senkron gövdelerin çektilmesi için.

Ürün No. 20-1+S-T

Seriler 20+S-T

EAN 4021176321344



	Teknik özellik	Metrik	Imparatorluk
	Açılma genişliği	30 - 90 mm	1 3/16 - 3 1/2 inch
	Derinlik	100 mm	3 7/8 inch
	İç çekme açılma genişliği	70 - 140 mm	2 3/4 - 5 1/2 inch
	Altıköşe geçme (erkek)	17 mm	
max.	İzin verilen maksimum yük	2,5 t	2.5 US t
	Maks. tork	35 Nm	25.5 ft lb
	Ağırlık	1.215 kg	
	Raum unterhalb	3 mm	1/8 inch
	Raum nebendran	12 mm	1/2 inch
	Çene sayısı	2	2



Teknolojiler



GLIDE & FIX

Optimal geometri çenenin giriş üzerinde kolayca ve hızlı kaydırılmasına izin verir.



ARMLOCK

Çapraz kancalar çenenin kayar parça içine asılmasında azami denge sağlar.



QUICK ADJUST

Çentikler çenelerin giriş üzerinde aletsiz ve hızlı serbest bırakılmasına ya da hareketine izin verir.



SWITCH

İki taraflı mil ucu sayesinde milin şaftla optimum uyumu.



Yedek parça

Ürün No.	Ürün adı
614160	Mekanik mil
1-95-P	2 çok dar, ayarlanabilir çekirme kolu (çift)
1-195-P	2 çok dar, ayarlanabilir çekirme kolu (çift)
1-255-P	2 çok dar, ayarlanabilir çekirme kolu (çift)
20-1-T	2 kollu gövde

Aksesuarlar

Ürün No.	Ürün adı
219-1	2 kollu çekirme aleti için gerdirme kelepçesi
1-195-P	2 çok dar, ayarlanabilir çekirme kolu (çift)
1-255-P	2 çok dar, ayarlanabilir çekirme kolu (çift)
K-600-014	KUKKO Milleri için, "6'sı 1 arada" değiştirilebilir Mil Uç Geçme Parçaları



Parçasıdır

Ürün No.	Ürün adı
EVLW-2-INDUSTRIE	Sanayi için satış panosu
EVLW-2-KFZ	Otomotiv için satış amaçlı pano
EVLW-2-NFZ	Otomotiv / ticari araçlar / tarım makineleri için satış amaçlı pano

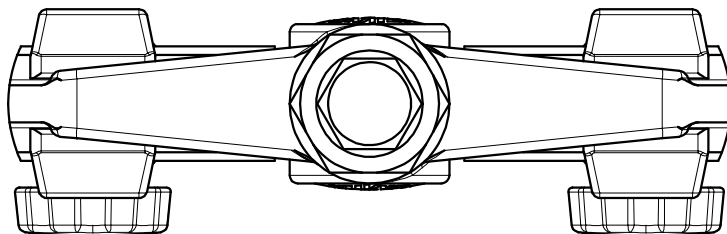
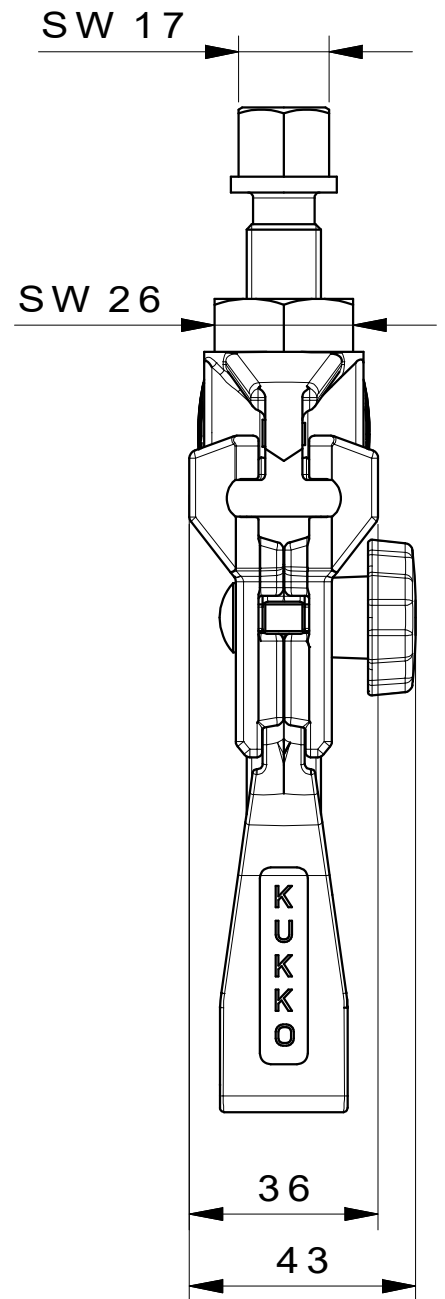
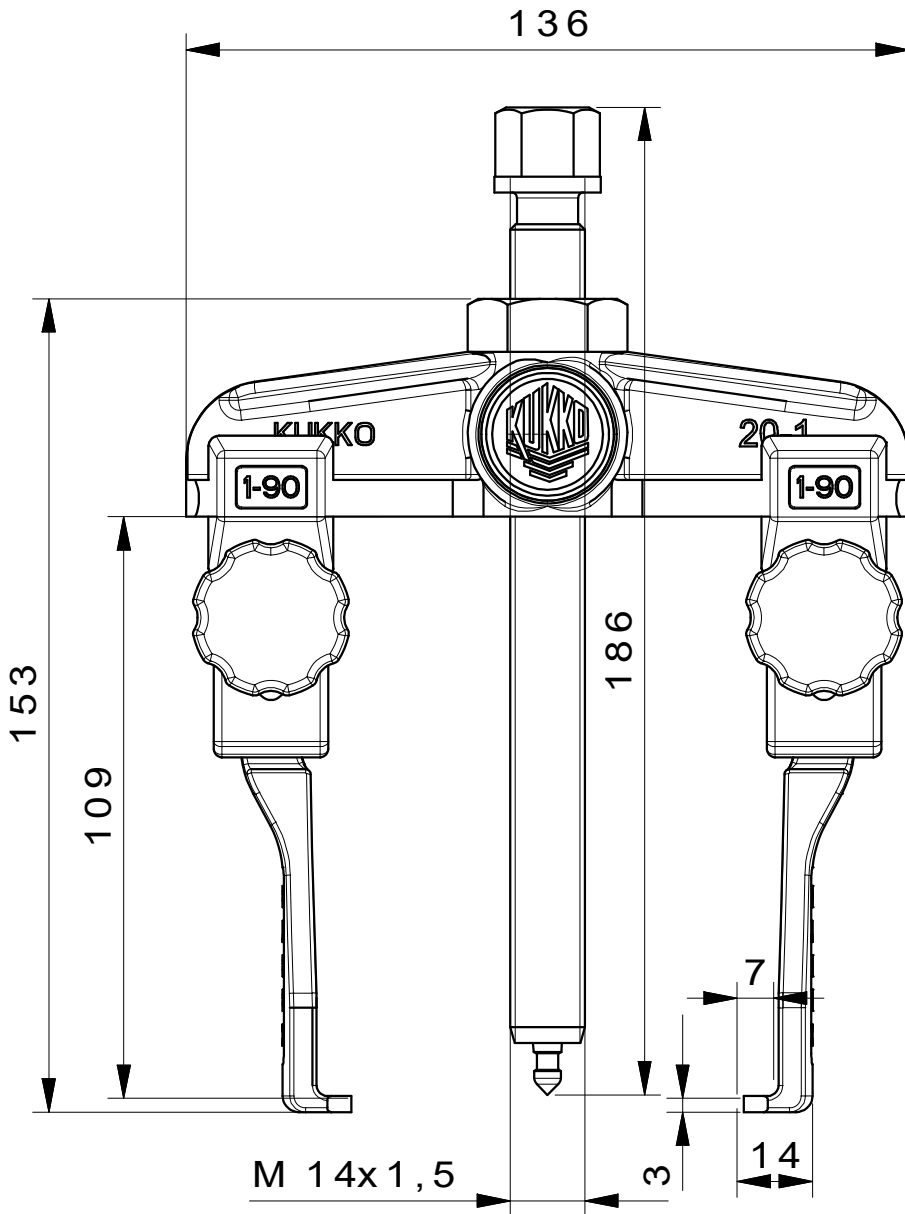
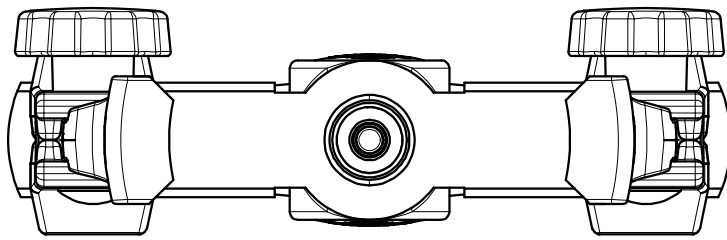

 Kleinbongartz & Kaiser oHG Werkzeugfabrik Hilden - Germany	Dokumentname: 20-1+S-T_2-Arm-Universal_Abzieher	Toleranz: DIN ISO 2768-m
	Dokumentbeschreibung: Baugruppe	Material: Hoch legierter Werkzeugstahl / High alloy tool steel
Erstellt / Geprüft von: Breidenbach	Erstellungsdatum: 29/08/2017	Maßstab: 1:1
Teilbeschreibung: 2-Arm-Universal_Abzieher mit schmalen Abzugshaken/ Universal 2-jaw puller with narrow jaws		Wärmebehandlung / Härte: vergüteter Stahl/ tempered steel
Artikelnummer / ZNR.: 20-1+S-T	Dokumentversion: -	Schutzvermerk ISO 16016 beachten