



Nome del prodotto

Estrattore universale a 2 bracci con profondità di serraggio regolabile



Per l'estrazione di cuscinetti, ingranaggi, pulegge ecc.

Num. art. 20-4-AV

Serie 20-AV/20-5

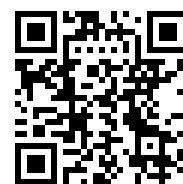
EAN 4021176706233



	Attributo tecnico	Metrico	Imperiale
	Ampiezza di serraggio esterna	80 - 520 mm	3 3/16 - 20 1/2 inch
	Profondità di serraggio	300 - 500 mm	11 7/8 - 19 3/4 inch
	Ampiezza di serraggio interna	200 - 590 mm	7 7/8 - 23 inch
	Esagono esterno	36 mm	
max.	Carico massimo consentito	12 t	1 US t
	Coppia massima	400 Nm	295 ft lb
	Peso	20.74 kg	
	Spazio sotto	25 mm	1 inch
	Spazio adiacente	85 mm	3 3/8 inch
	Numero delle griffe	2	2



Tecnologie



SWITCH

Adattamento ottimale dei mandrini all'albero grazie alla punta bilaterale dei mandrini.



Pezzo di ricambio

Num. art.	Nome del prodotto
633500	Vite di pressione meccanica.
4-SP-P	2 griffe con lunghezza regolabile (paio)
20-4-T	Traversa a 2 bracci

Acessori

Num. art.	Nome del prodotto
8-1-B	Vite idraulica lunga
9-1	Pressa idraulica supplementare
9-2	Pressa idraulica supplementare
9-3	Pressa idraulica supplementare
3-200-P	2 griffe (paio)
3-300-P	2 griffe allungate (paio)
3-400-P	2 griffe allungate (paio)
3-500-P	2 griffe allungate (paio)
4-SP-E	Griffa (singola)
3-250-P	2 griffe (paio)
11-0-T	Traversa



Utilizzi alternativi

Num. art.	Nome del prodotto
9-2	Pressa idraulica supplementare
9-3	Pressa idraulica supplementare
3-202-P	2 griffe a regolazione rapida (paio)
3-302-P	2 griffe a regolazione rapida (paio)
3-402-P	2 griffe a regolazione rapida (paio)
3-502-P	2 griffe a regolazione rapida (paio)

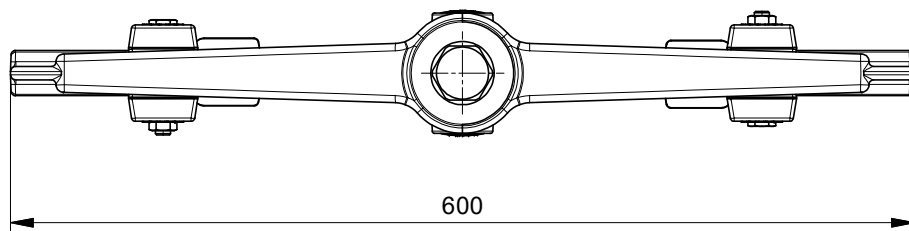
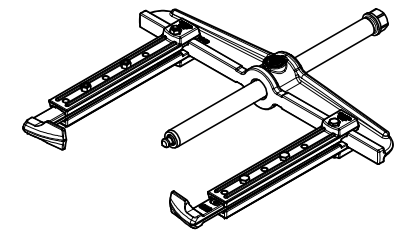
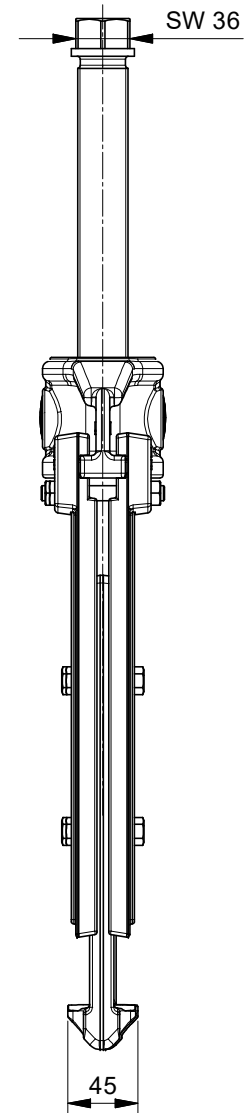
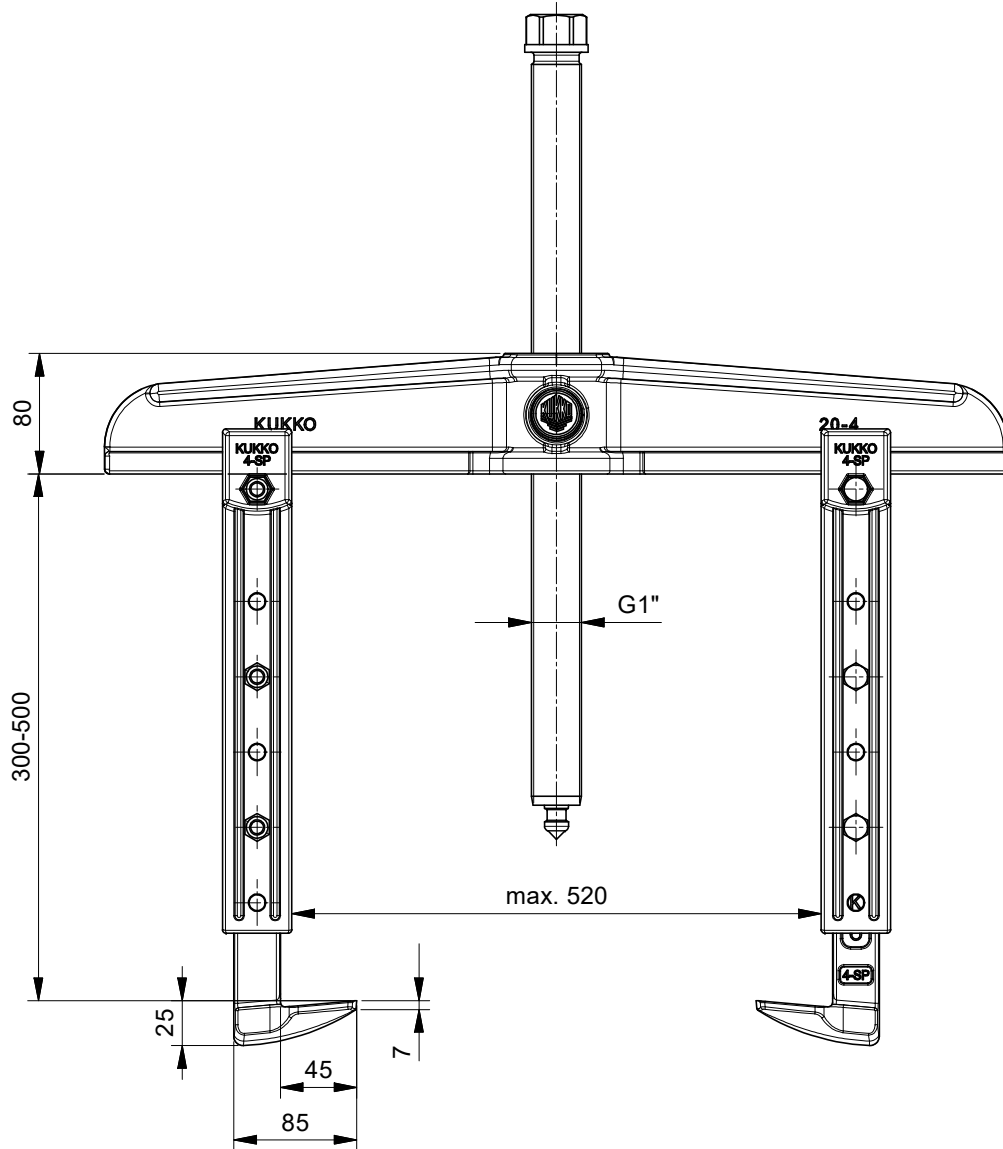

 Kleinbongartz & Kaiser oHG Werkzeugfabrik Hilden - Germany	Dokumentname: 20-4-AV_2-armiger Universal Abzieher	Toleranz: DIN ISO 2768-m
	Dokumentbeschreibung: Baugruppe	Material: Hoch legierter Werkzeugstahl / High alloy tool steel
Erstellt von: Breidenbach	Erstellungsdatum: 06/12/2018	Maßstab: 1:2.5
Teilbeschreibung: 2-armiger Universal Abzieher mit verstellbarer Spannweite/ Universal 2-jaw puller with adjustable reach		Wärmebehandlung / Härte: vergüteter Stahl/ tempered steel
Oberflächenbehandlung: -		
Artikelnummer / ZNR.: 20-4-AV	Dokumentversion: -	Schutzvermerk ISO 16016 beachten