



Nome do produto

Extrator universal de 2 braços com profundidade de fixação ajustável











Para remover rolamentos, engrenagens, discos, etc.

Artigo Nº 20-4-AV

Série 20-AV/20-5

EAN 4021176706233



Características	Métrico	Polegada
 Extensão externa	80 - 520 mm	3 3/16 - 20 1/2 inch
 Profundidade de fixação	300 - 500 mm	11 7/8 - 19 3/4 inch
 Extensão interna	200 - 590 mm	7 7/8 - 23 inch
 Hexágono externo	36 mm	
 max. Carga máxima permitida	12 t	1 US t
 max. Binário máx.	400 Nm	295 ft lb
 Peso	20.74 kg	
 Quarto abaixo	25 mm	1 inch
 Quarto de drenagem secundária	85 mm	3 3/8 inch
 Número de ganchos	2	2



Tecnologias



SWITCH

Ajuste ótimo do fuso ao eixo graças à ponta do fuso de duas faces.



Peça de substituição

Artigo Nº	Nome do produto
633500	Eixo de compressão mecânico.
4-SP-P	2 ganchos de extração de comprimento ajustável (par)
20-4-T	Travessa de 2 braços

Acessórios

Artigo Nº	Nome do produto
8-1-B	Eixo hidráulico longo
9-1	Prensa hidráulica auxiliar
9-2	Prensa hidráulica auxiliar
9-3	Prensa hidráulica auxiliar
3-200-P	2 ganchos de extração (par)
3-300-P	2 ganchos de extração prolongados (par)
3-400-P	2 ganchos de extração prolongados (par)
3-500-P	2 ganchos de extração prolongados (par)
4-SP-E	1 gancho de extração (individual)
3-250-P	2 ganchos de extração (par)
11-0-T	Travessa



Em alternativa pode ser utilizado com

Artigo Nº	Nome do produto
9-2	Prensa hidráulica auxiliar
9-3	Prensa hidráulica auxiliar
3-202-P	2 ganchos de extração de ajuste rápido (par)
3-302-P	2 ganchos de extração de ajuste rápido (par)
3-402-P	2 ganchos de extração de ajuste rápido (par)
3-502-P	2 ganchos de extração de ajuste rápido (par)

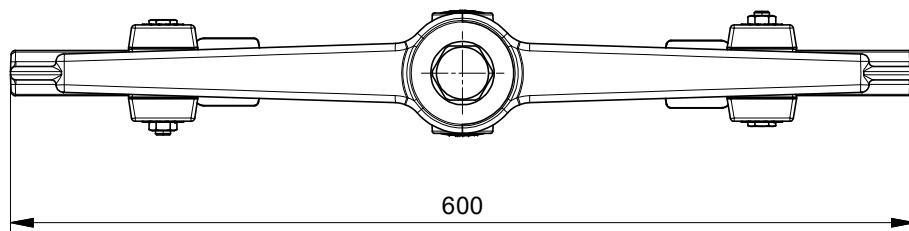
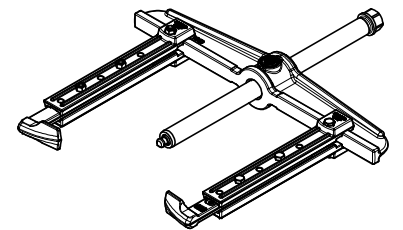
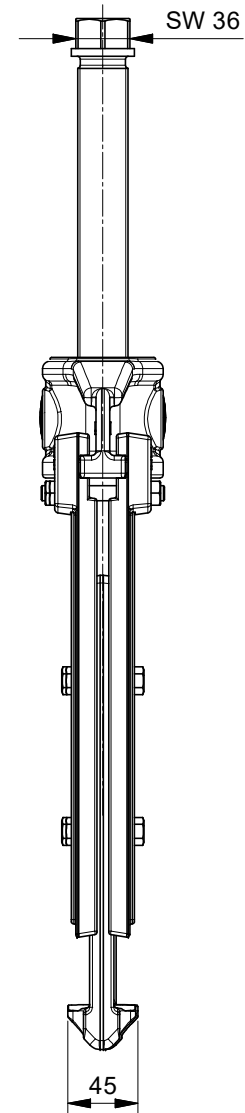
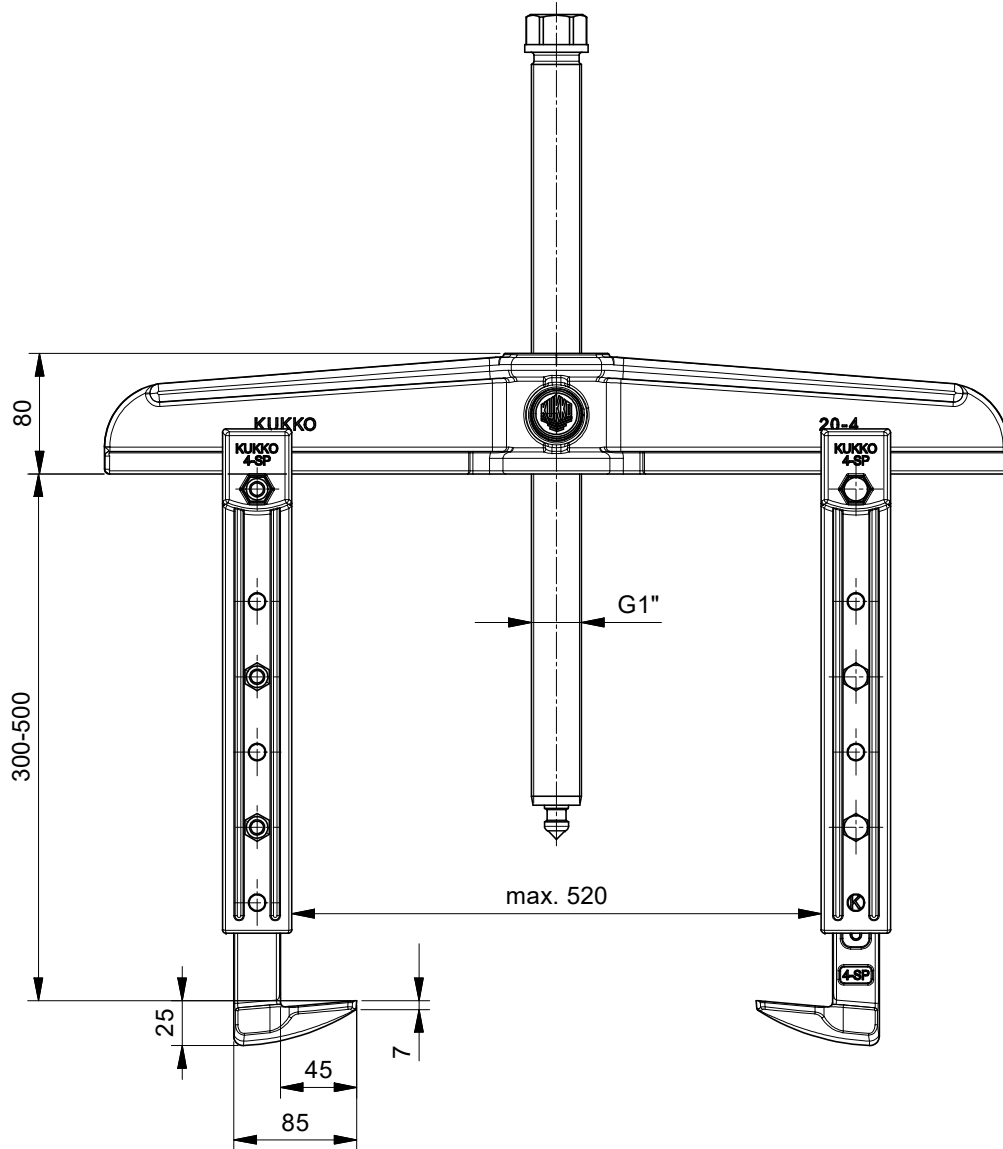

 Kleinbongartz & Kaiser oHG Werkzeugfabrik Hilden - Germany	Dokumentname: 20-4-AV_2-armiger Universal Abzieher	Toleranz: DIN ISO 2768-m
	Dokumentbeschreibung: Baugruppe	Material: Hoch legierter Werkzeugstahl / High alloy tool steel
Erstellt von: Breidenbach	Erstellungsdatum: 06/12/2018	Maßstab: 1:2.5
Teilbeschreibung: 2-armiger Universal Abzieher mit verstellbarer Spanntiefe/ Universal 2-jaw puller with adjustable reach		Wärmebehandlung / Härte: vergüteter Stahl/ tempered steel
Oberflächenbehandlung: -		Schutzvermerk ISO 16016 beachten
Artikelnummer / ZNR.: 20-4-AV	Dokumentversion: -	