



Ürün adı

## 2 kollu universal çektilme - derinliđi ayarlanabilir



Yatakları, dişlileri, rondelaları vb. çıkarmak için.

Ürün No. 20-4-AV

Seriler 20-AV/20-5

EAN 4021176706233



	<b>Teknik özellik</b>	<b>Metrik</b>	<b>İmparatorluk</b>
	Açılma genişliđi	80 - 520 mm	3 3/16 - 20 1/2 inch
	Derinlik	300 - 500 mm	11 7/8 - 19 3/4 inch
	İç çektilme açılma genişliđi	200 - 590 mm	7 7/8 - 23 inch
	Altıköşe geçme (erkek)	36 mm	
max.	İzin verilen maksimum yük	12 t	1 US t
	Maks. tork	400 Nm	295 ft lb
	Ağırlık	20.74 kg	
	Raum unterhalb	25 mm	1 inch
	Raum nebendran	85 mm	3 3/8 inch
	Çene sayısı	2	2



## Teknolojiler



### SWITCH

İki taraflı mil ucu sayesinde milin  
şaftla optimum uyumu.



## Yedek parça

Ürün No.	Ürün adı
633500	Mekanik mil
4-SP-P	Ayarlanabilir uzunlukta 2 çektirme kolu (çift)
20-4-T	2 kollu gövde

## Aksesuarlar

Ürün No.	Ürün adı
8-1-B	Uzun hidrolik mil
9-1	Yardımcı hidrolik koç
9-2	Yardımcı hidrolik koç
9-3	Yardımcı hidrolik koç
3-200-P	2 çektirme kolu (çift)
3-300-P	2 ve 3 parçalı iç çektirme kolu (çift)
3-400-P	2 ve 3 parçalı iç çektirme kolu (çift)
3-500-P	2 ve 3 parçalı iç çektirme kolu (çift)
4-SP-E	1 çektirme kolu (tek)
3-250-P	2 çektirme kolu (çift)
11-0-T	Gövde



## Alternatif olarak birlikte kullanılabilir

Ürün No.	Ürün adı
9-2	Yardımcı hidrolik koç
9-3	Yardımcı hidrolik koç
3-202-P	2 hızlı ayarlanabilir çekme kolu (çift)
3-302-P	2 hızlı ayarlanabilir çekme kolu (çift)
3-402-P	2 hızlı ayarlanabilir çekme kolu (çift)
3-502-P	2 hızlı ayarlanabilir çekme kolu (çift)

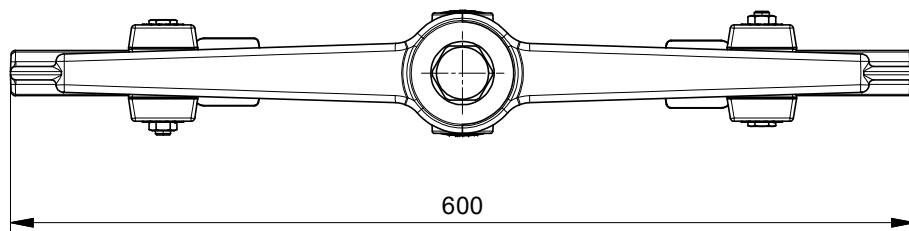
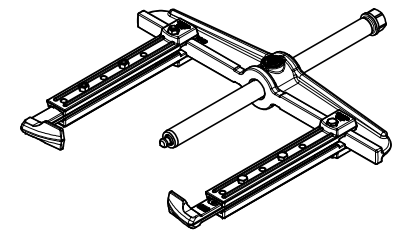
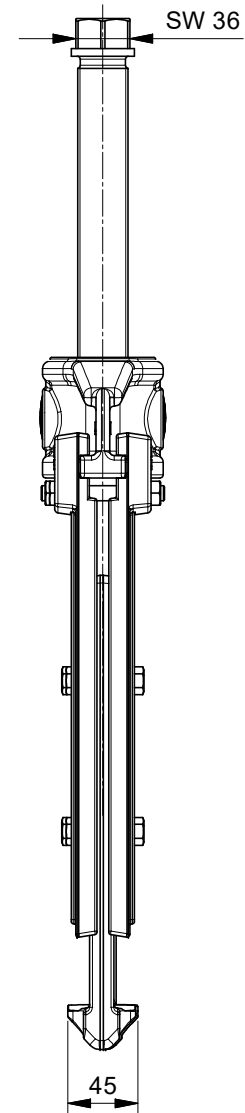
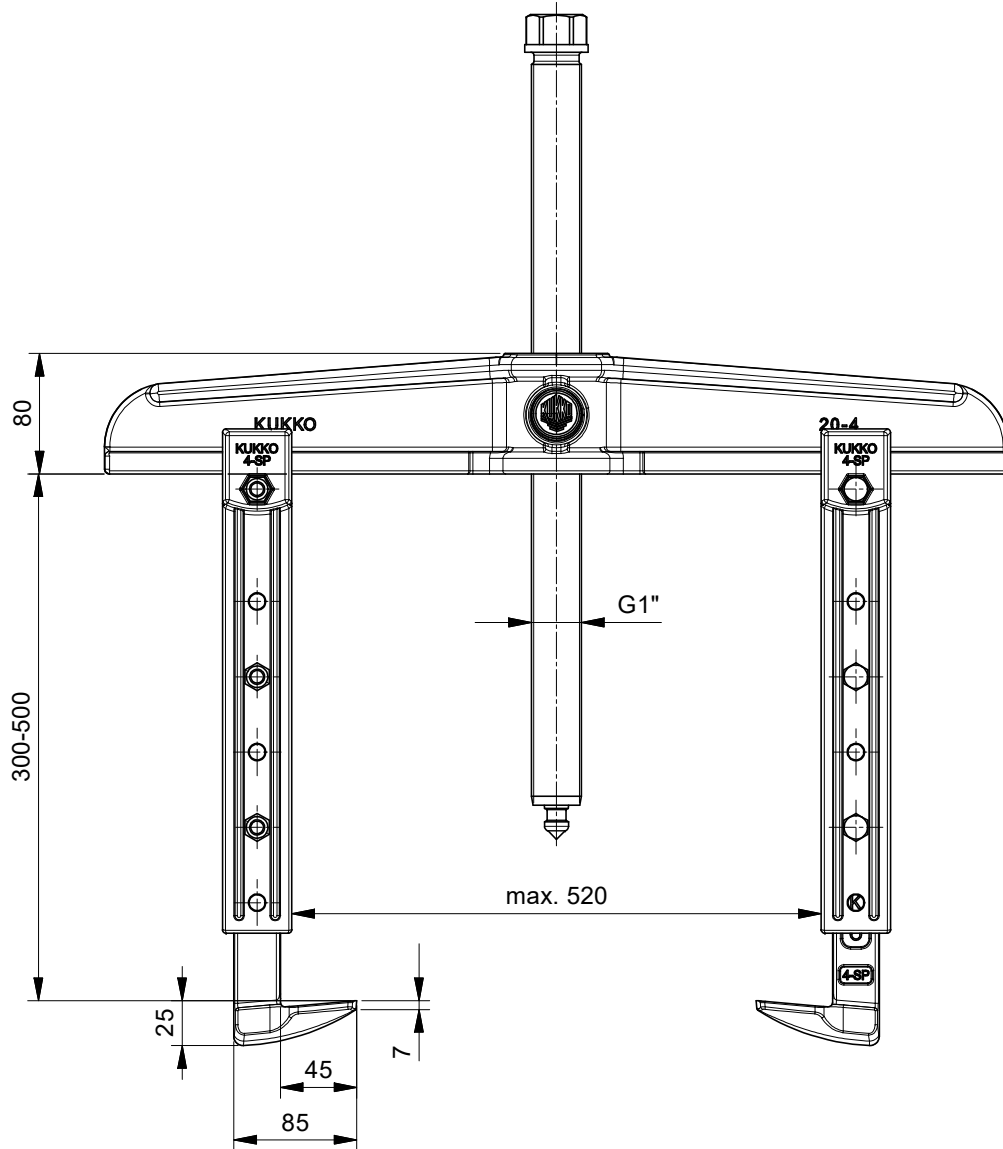

 <b>Kleinbongartz &amp; Kaiser oHG</b> Werkzeugfabrik Hilden - Germany	Dokumentname: <b>20-4-AV_2-armiger Universal Abzieher</b>	Toleranz: <b>DIN ISO 2768-m</b>
	Dokumentbeschreibung: <b>Baugruppe</b>	Material: Hoch legierter Werkzeugstahl / High alloy tool steel
Erstellt von: Breidenbach	Erstellungsdatum: 06/12/2018	Maßstab: 1:2.5
Teilbeschreibung: 2-armiger Universal Abzieher mit verstellbarer Spanntiefe/ Universal 2-jaw puller with adjustable reach		Wärmebehandlung / Härte: vergüteter Stahl/ tempered steel
Oberflächenbehandlung: -		
Artikelnummer / ZNR.: 20-4-AV	Dokumentversion: -	Schutzvermerk ISO 16016 beachten