



Nome del prodotto

Estrattore universale a 2 bracci con profondità di serraggio regolabile

Per l'estrazione di cuscinetti, ingranaggi, pulegge ecc.

Num. art. 20-5

Serie 20

EAN 4021176009846

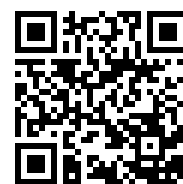

	Attributo tecnico	Metrico	Imperiale
	Ampiezza di serraggio esterna	105 - 750 mm	4 1/8 - 29 1/2 inch
	Profondità di serraggio	400 - 700 mm	15 3/4 - 27 5/8 inch
	Ampiezza di serraggio interna	340 - 1000 mm	13 3/8 - 40 inch
	Esagono esterno	41 mm	
	Coppia massima	650 Nm	479.5 ft lb
	Carico massimo consentito	15,0 t	16.5 US t
	Numero delle griffe	2	2
	Peso	47 kg	
	Spazio sotto	20 mm	3/4 inch
	Spazio adiacente	67 mm	2 5/8 inch



Tecnologie



GLIDE & FIX

La geometria ottimizzata garantisce una scorrevolezza facile e rapida dei ganci di estrazione sulla traversa.



ARMLOCK

I ganci a croce garantiscono la massima stabilità per la sospensione dei ganci di estrazione nel pezzo scorrevole.



SWITCH

Adattamento ottimale dei mandrini all'albero grazie alla punta bilaterale dei mandrini.



Pezzo di ricambio

Num. art.	Nome del prodotto
637600	Vite di pressione meccanica.
5-SP-P	2 griffe con lunghezza regolabile (paio)
20-5-T	Traversa a 2 bracci

Acessori

Num. art.	Nome del prodotto
8-2-M	Vite idraulica lunga
9-1	Pressa idraulica supplementare
9-2	Pressa idraulica supplementare
9-3	Pressa idraulica supplementare
5-SP-E	Griffe singole

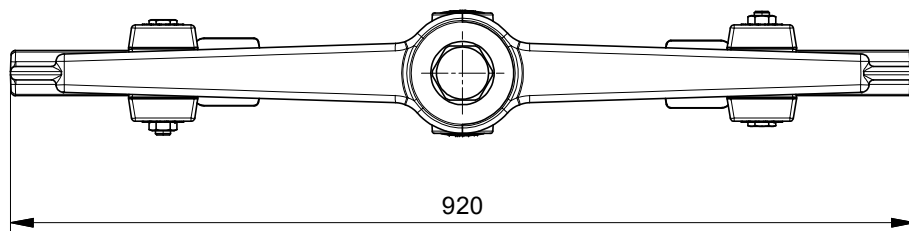
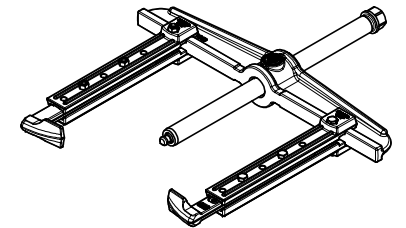
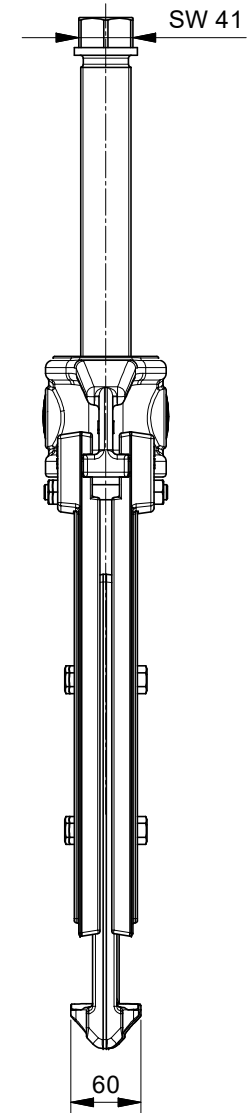
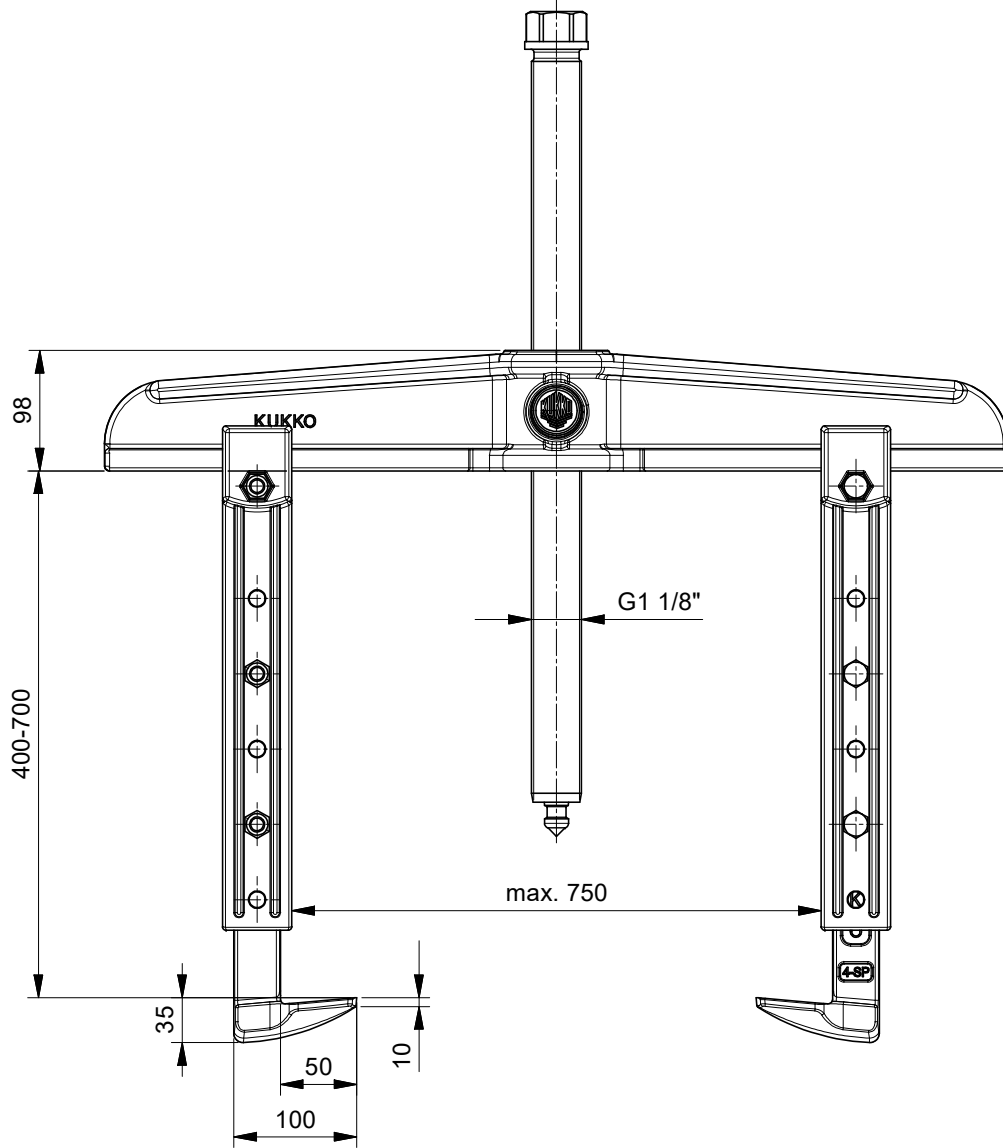

 Kleinbongartz & Kaiser oHG Werkzeugfabrik Hilden - Germany	Dokumentname: 20-5_2-armiger Universal Abzieher	Toleranz: DIN ISO 2768-m
	Dokumentbeschreibung: Baugruppe	Material: Hoch legierter Werkzeugstahl / High alloy tool steel
Erstellt von: Breidenbach	Erstellungsdatum: 06/12/2018	Maßstab: 1:2.5
Teilbeschreibung: 2-armiger Universal Abzieher mit verstellbarer Spannweite / Universal 2-jaw puller with adjustable reach		Wärmebehandlung / Härte: vergüteter Stahl / tempered steel
Artikelnummer / ZNR.: 20-5		Oberflächenbehandlung: -
Dokumentversion: -	Schutzvermerk: ISO 16616 beachten	