



产品名称

## 通用两爪拉马带可调节范围

用于拆卸轴承、齿轮、圆盘等。

编号 20-5

系列 20

EAN 4021176009846



技术规格	公制	英制
 跨度	105 - 750 mm	4 1/8 - 29 1/2 inch
 深度	400 - 700 mm	15 3/4 - 27 5/8 inch
 内部使用扩展	340 - 1000 mm	13 3/8 - 40 inch
 六角驱动 (公)	41 mm	
 max. 最大扭矩	650 Nm	479.5 ft lb
 max. 最大负载	15,0 t	16.5 US t
 x 拉马爪数量	2	2
 重量	47 kg	
 下方空间	20 mm	3/4 inch
 邻近空间	67 mm	2 5/8 inch



## 技术



### 滑动&固定

优化的几何形状保证拉马爪能在横梁上轻松快速移动。



### 臂锁

十字爪最大程度地保证了滑块中拉马爪悬挂的稳定性。



### 开关

通过两边的轴尖来调整优化主轴的位置。



## 配件

编号	产品名称
637600	机械压力主轴。
5-SP-P	两只可调节长度拉马爪（对）
20-5-T	两爪横杆

## 附件

编号	产品名称
8-2-M	长液压主轴
9-1	辅助液压油缸。
9-2	辅助液压油缸。
9-3	辅助液压油缸。
5-SP-E	拉马爪，单个

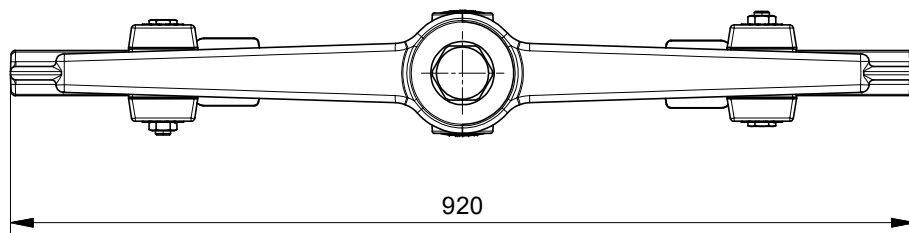
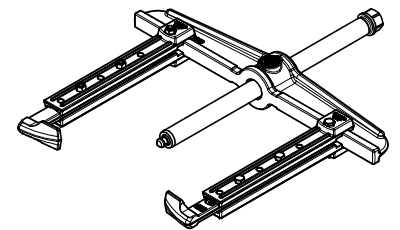
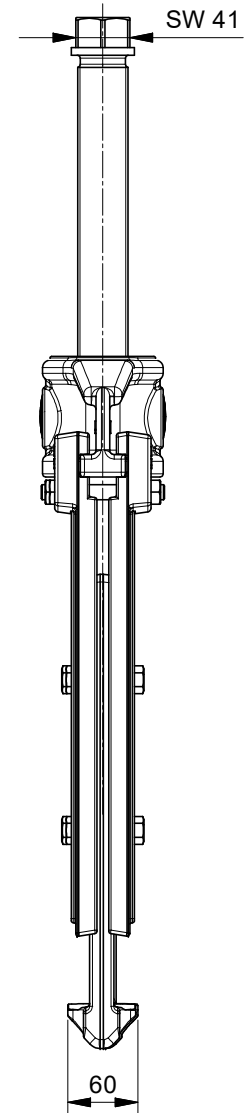
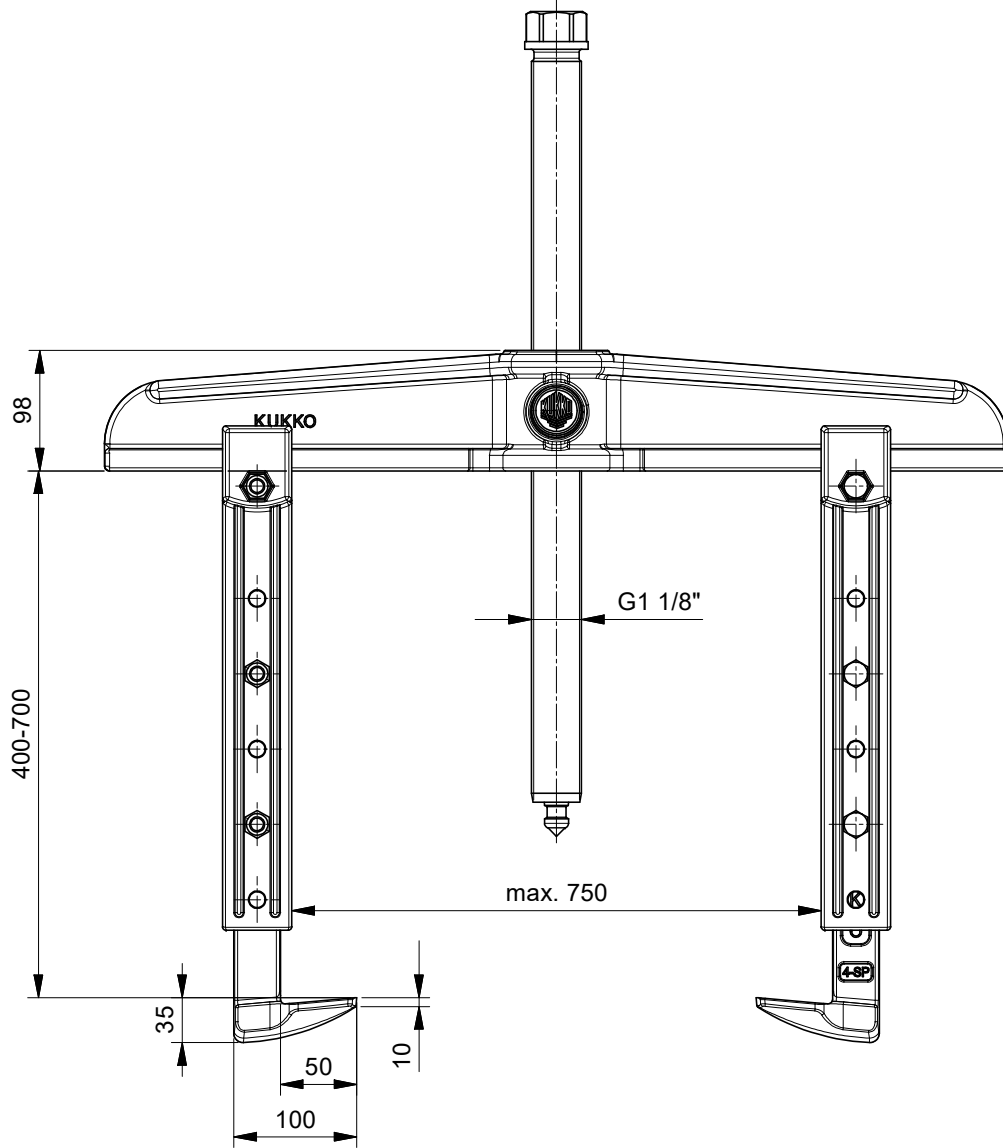

 <b>Kleinbongartz &amp; Kaiser oHG</b> Werkzeugfabrik Hilden - Germany	Dokumentname: <b>20-5_2-armiger Universal Abzieher</b>	Toleranz: <b>DIN ISO 2768-m</b>
	Dokumentbeschreibung: <b>Baugruppe</b>	Material: <b>Hoch legierter Werkzeugstahl / High alloy tool steel</b>
Erstellt von: <b>Breidenbach</b>	Erstellungsdatum: <b>06/12/2018</b>	Maßstab: <b>1:2.5</b>
Teilbeschreibung: <b>2-armiger Universal Abzieher mit verstellbarer Spannweite / Universal 2-jaw puller with adjustable reach</b>		Wärmebehandlung / Härte: <b>vergüteter Stahl / tempered steel</b>
Artikelnummer / ZNR.: <b>20-5</b>		Oberflächenbehandlung: <b>-</b>
Dokumentversion: <b>-</b>	Schutzvermerk: <b>ISO 16616 beachten</b>	