



Product name

## Internal extractor

For extracting inner bearings, bearing outer rings and bushings.

Art. No. 21-00

Series 21

EAN 4021176010576

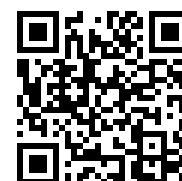

### Technical attribute

### Metric

### Imperial



Ball bearing ISO

626; 607; 627; 608;	626; 607; 627; 608;
619/8; 628/8; 609;	619/8; 628/8; 609;
618/9; 629; 6000;	618/9; 629; 6000;
6200; 6300; 6800;	6200; 6300; 6800;
6900; 61800; 61900;	6900; 61800; 61900;
62200; 62300	62200; 62300



Inner diameter of ball bearing

6 - 10 mm

1/4 - 3/8 inch



Effective depth

14 mm

5/8 inch



Length of internal extractor

73 mm

2 7/8 inch



Number of segments

2

2



Weight

0.12 kg



has to be accomplished with

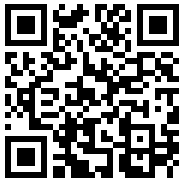

**Slide hammer device**

22-0

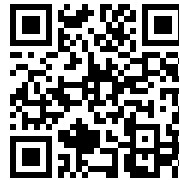

**Counterstay**

22-1



## Accessories

<b>Art. No.</b>	<b>Product name</b>
21-V-040	Extension for internal extractor
21-V-0	Set of extensions for internal extractors

## Goes with

<b>Art. No.</b>	<b>Product name</b>
22-1	Counterstay

## Part of

<b>Art. No.</b>	<b>Product name</b>
25-K	Set of bearing extracting tools
28-A	Set of slide hammer for extracting ball bearings and dowel-pins
K-26-A	Set of bearing extracting tools
K-22-A	Ball bearing extracting set with counterstay and slide hammer
EVLW-INDUSTRIE BASIC	Display



## Spare part of

**Art. No.**

**Product name**

25-K

Set of bearing extracting tools

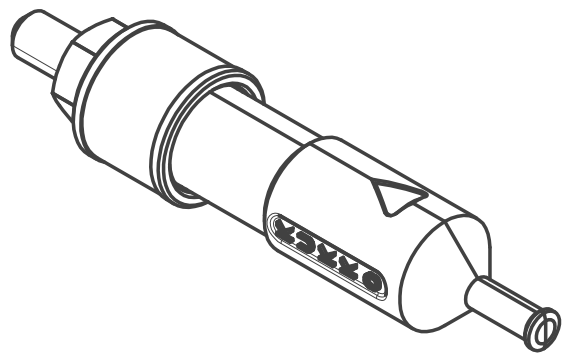
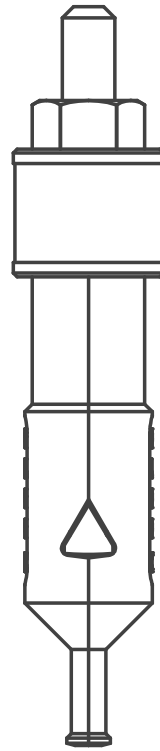
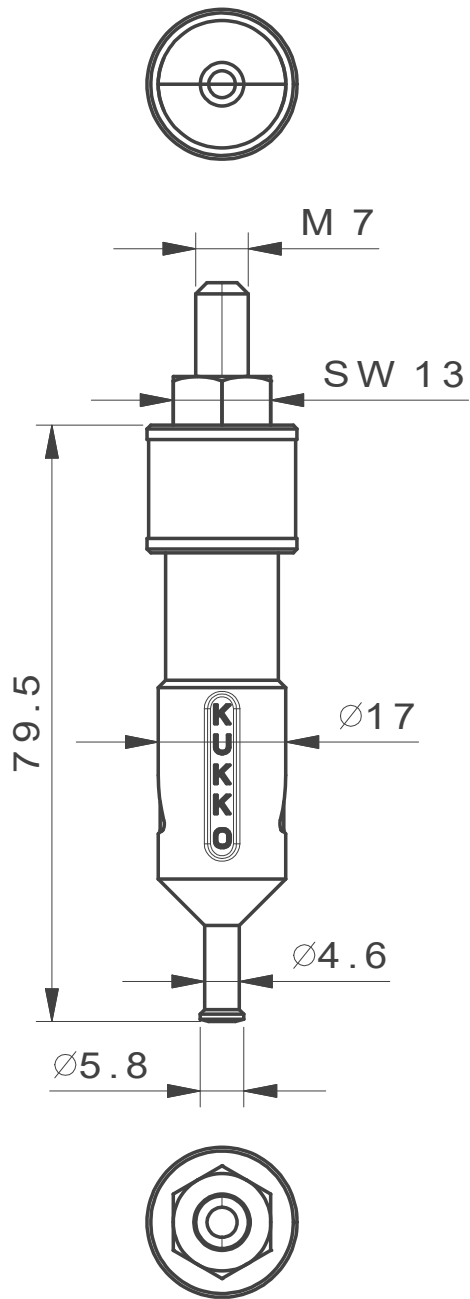

 <p><b>Kleinbongartz &amp; Kaiser oHG</b> Werkzeugfabrik Hilden - Germany</p>	Dokumentname: 21-00 Innenauszieher		Toleranz: DIN ISO 2768-m
	Dokumentbeschreibung: ZSB		Material: Hochfester extra zäher Vergütungsstahl/ High tensile strength and toughness steel
	Erstellt / Geprüft von: Schultes	Erstellungsdatum: 05/06/2015	Maßstab: 1:1
Teilbeschreibung: Innenauszieher/ Internal extractor		Wärmebehandlung / Härte: vergüteter Stahl/ tempered steel	
		Oberflächenbehandlung:	
Artikelnummer / ZNR.: 21-00	Dokumentversion: -	Schutzvermerk ISO 16016 beachten	