



Produktnavn

## 2-armet indvendig udtrækker

Til udtrækning af indvendige lejer, lejeyderringe og bøsninger.

Varenr. 21-01

Serie 21

EAN 4021176010651



### Teknisk egenskab

### Metrisk

### Tomme



Kugleleje ISO

608; 619/8; 628/8;	608; 619/8; 628/8;
609; 618/9; 629;	609; 618/9; 629;
6000; 6200; 6300;	6000; 6200; 6300;
6800; 6900; 61800;	6800; 6900; 61800;
61900; 62200;	61900; 62200;
62300; 6001; 6201;	62300; 6001; 6201;
6301; 6801; 6901;	6301; 6801; 6901;
16001; 16101;	16001; 16101;
61801; 61901;	61801; 61901;
62201; 62301	62201; 62301



Kuglelejets indvendige diameter

8 - 12 mm

3/8 - 1/2 inch



Monteringsdybde

14 mm

5/8 inch



Længde af indvendig udtrækker

73 mm

2 7/8 inch



Antal segmenter

2

2



Vægt

0.115 kg



## Skal udføres med



### **Glidehammeranordning**

22-0



### **Modstøtter**

22-1



## Tilbehør

Varenr.	Produktnavn
21-V-040	Forlængelse til indvendige aftrækkere
21-V-0	Sæt forlængelser til indvendige aftrækkere

## Gå med

Varenr.	Produktnavn
22-1	Modstøtter

## Er bestanddel af

Varenr.	Produktnavn
28-A	Glidehammersæt til udtrækning af kuglelejer og stifter
EVLW-2-INDUSTRIE	Salgsvæg industri
EVLW-INDUSTRIE BASIC	Salgsvæg industri

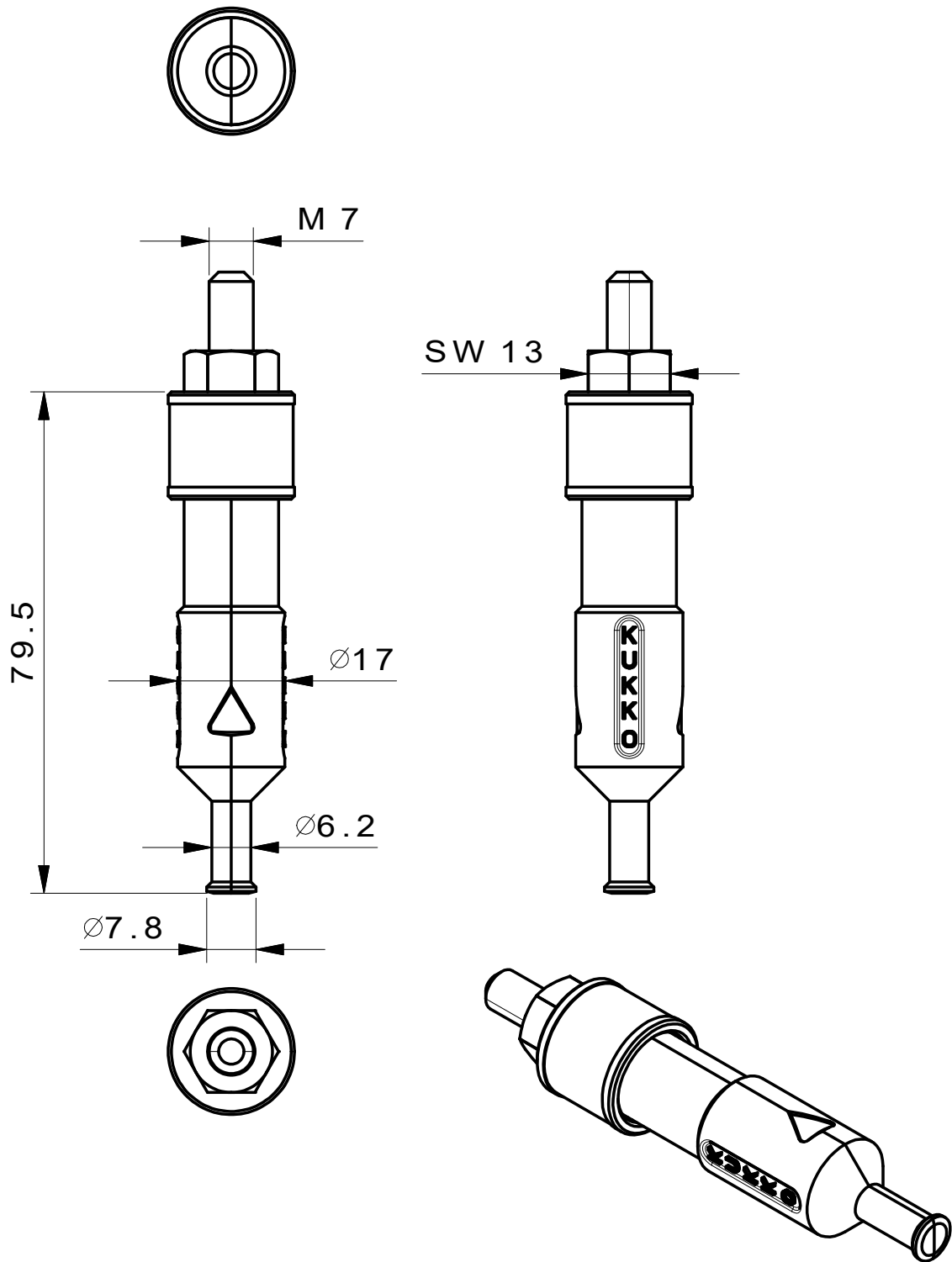

 <p><b>Kleinbongartz &amp; Kaiser oHG</b> Werkzeugfabrik Hilden - Germany</p>	Dokumentname: 21-01 Innenauszieher		Toleranz: DIN ISO 2768-m	
	Dokumentbeschreibung: ZSB		Material: Hochfester extra zäher Vergütungsstahl/ High tensile strength and toughness steel	
	Erstellt / Geprüft von: Schultes	Erstellungsdatum: 05/06/2015	Maßstab: 1:1	
Teilbeschreibung: Innenauszieher/ Internal extractor			Wärmebehandlung / Härte: vergüteter Stahl/ tempered steel	
			Oberflächenbehandlung:	
Artikelnummer / ZNR.: 21-01	Dokumentversion: -		Schutzvermerk ISO 16016 beachten	