



Nome del prodotto

## Estrattore interno a 2 strati

Per l'estrazione di cuscinetti interni, anelli di cuscinetti e bocche.

Num. art. 21-01

Serie 21

EAN 4021176010651



### Attributo tecnico

### Metrico

### Imperiale



Cuscinetto a sfera ISO

608; 619/8; 628/8;	608; 619/8; 628/8;
609; 618/9; 629;	609; 618/9; 629;
6000; 6200; 6300;	6000; 6200; 6300;
6800; 6900; 61800;	6800; 6900; 61800;
61900; 62200;	61900; 62200;
62300; 6001; 6201;	62300; 6001; 6201;
6301; 6801; 6901;	6301; 6801; 6901;
16001; 16101;	16001; 16101;
61801; 61901;	61801; 61901;
62201; 62301	62201; 62301



Diametro interno del cuscinetto a sfere

8 - 12 mm

3/8 - 1/2 inch



Profondità di inserimento

14 mm

5/8 inch



Lunghezza estrattore interno

73 mm

2 7/8 inch



Numero di segmenti

2

2



Peso

0.115 kg



esige anche



**Dispositivi battenti**

22-0



**Controsupporti**

22-1



## Acessori

<b>Num. art.</b>	<b>Nome del prodotto</b>
21-V-040	Prolunga per estrattore interno
21-V-0	Set di prolunghes per estrattore interno

## Viene utilizzato da

<b>Num. art.</b>	<b>Nome del prodotto</b>
22-1	Controsupporti

## é parte di

<b>Num. art.</b>	<b>Nome del prodotto</b>
28-A	Set di estrattori a battenti per cuscinetti e spine cilindriche
EVLW-2-INDUSTRIE	Display di vendita Industria
EVLW-INDUSTRIE BASIC	Display di vendita Industria

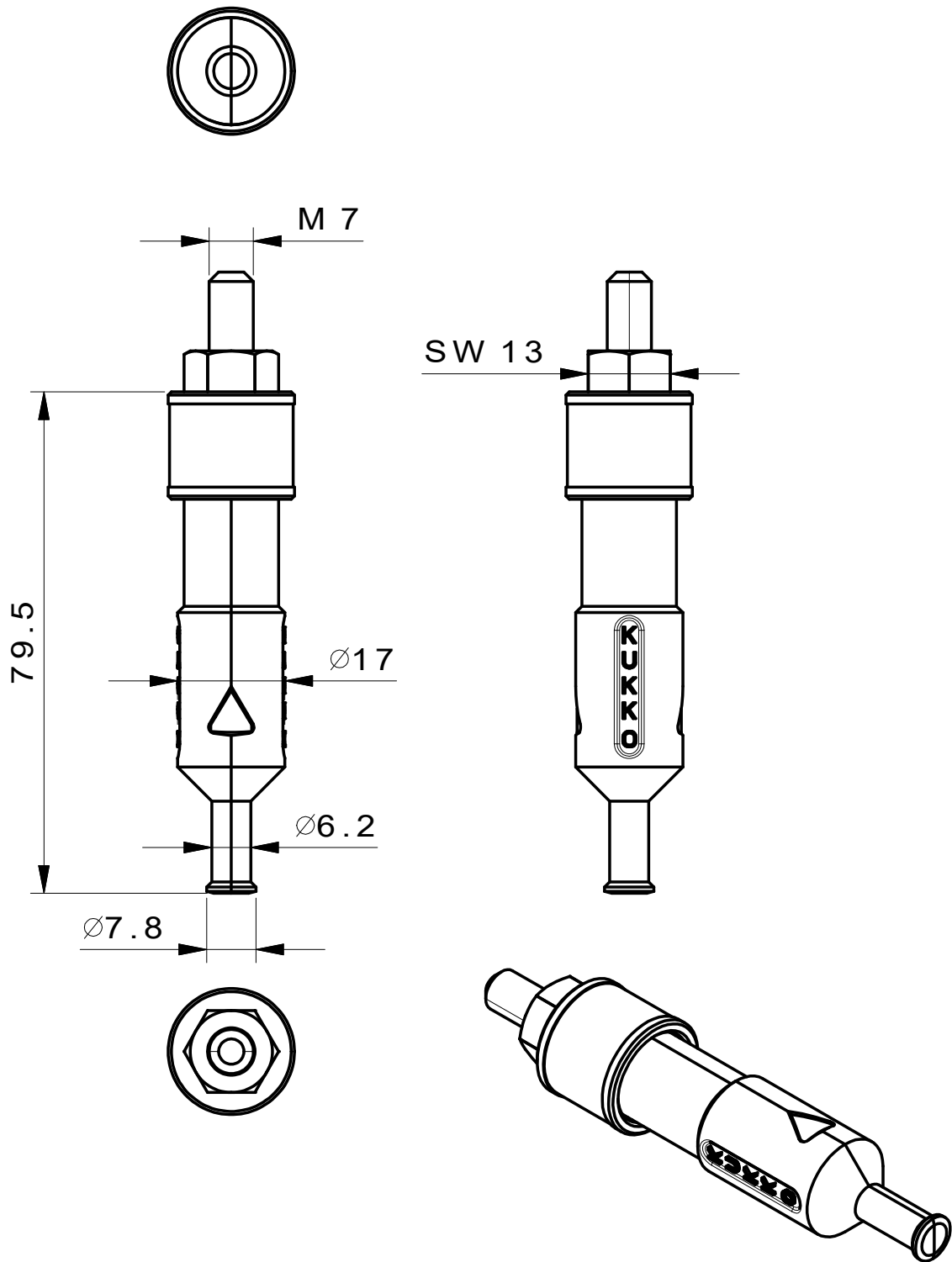

 <p><b>Kleinbongartz &amp; Kaiser oHG</b> Werkzeugfabrik Hilden - Germany</p>	Dokumentname: 21-01 Innenauszieher		Toleranz: DIN ISO 2768-m
	Dokumentbeschreibung: ZSB		Material: Hochfester extra zäher Vergütungsstahl/ High tensile strength and toughness steel
	Erstellt / Geprüft von: Schultes	Erstellungsdatum: 05/06/2015	Maßstab: 1:1
Teilbeschreibung: Innenauszieher/ Internal extractor		Wärmebehandlung / Härte: vergüteter Stahl/ tempered steel	
		Oberflächenbehandlung:	
Artikelnummer / ZNR.: 21-01	Dokumentversion: -	Schutzvermerk ISO 16016 beachten	