



Product name

Internal extractor with segmented grasp edge

For extracting bearings, bearing outer rings and bushings that lay flat on one another.

Art. No. 21-1-E

Series 21-E

EAN 4021176930003



Technical attribute

Metric

Imperial



Ball bearing ISO

6001; 6201; 6301;	6001; 6201; 6301;
6801; 6901; 16001;	6801; 6901; 16001;
16101; 61801;	16101; 61801;
61901; 62201;	61901; 62201;
62301; 6002; 6202;	62301; 6002; 6202;
6302; 6802; 6902;	6302; 6802; 6902;
16002; 61802;	16002; 61802;
61902	61902



Inner diameter of ball bearing

12 - 16 mm

1/2 - 5/8 inch



Effective depth

35 mm

1 3/8 inch



Length of internal extractor

80 mm

3 3/16 inch



Number of segments

3

3



Spanner size of the internal extractor

22 mm



Weight

0.17 kg



has to be accomplished with

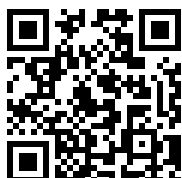

Slide hammer device

22-0

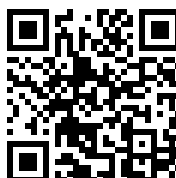

Slide hammer device

22-0-1

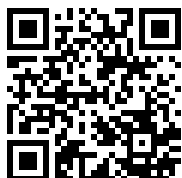

Counterstay

22-1



Counterstay

22-2



Goes with

Art. No.	Product name
22-1	Counterstay
22-2	Counterstay

Part of

Art. No.	Product name
27-A	Universal puller set
K-22-C-E	Ball bearing extracting set with counterstay and slide hammer
K-22-A-E	Ball bearing extracting set with counterstay and slide hammer
K-22-B-E	Ball bearing extracting set with counterstay and slide hammer
WT-017	Puller product range - interior pulling - BASIC

Spare part of

Art. No.	Product name
27-A	Universal puller set

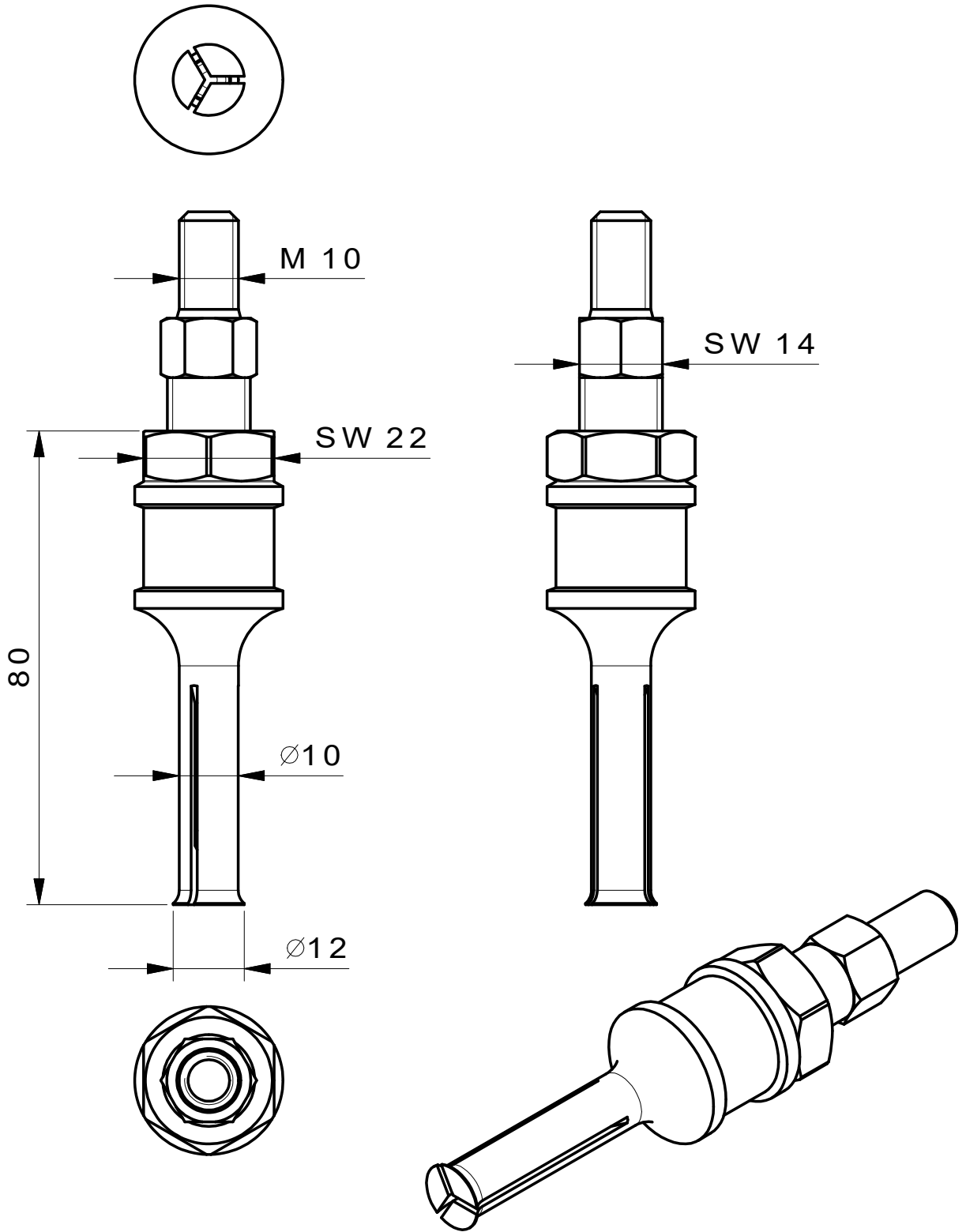

 <p>Kleinbongartz & Kaiser oHG Werkzeugfabrik Hilden - Germany</p>	Dokumentname: 21-1-E_Segment-Innenauszieher		Toleranz: DIN ISO 2768-m	
	Dokumentbeschreibung: Baugruppe		Material: Hochfester extra zäher Vergütungsstahl/ High tensile strength and toughness steel	
	Erstellt von: Breidenbach	Erstellungsdatum: 10/05/2016	Maßstab: 1:1	
Teilbeschreibung: Segment-Innenauszieher/ Internal extractor with segmented grasp edge			Wärmebehandlung / Härte: vergüteter Stahl/ tempered steel	
			Oberflächenbehandlung:	
Artikelnummer / ZNR.: 21-1-E	Dokumentversion: -		Schutzvermerk ISO 16016 beachten	