



Product name

## Internal extractor with segmented grasp edge

For extracting bearings, bearing outer rings and bushings that lay flat on one another.

Art. No. 21-3-E

Series 21-E

EAN 4021176931109



### Technical attribute

### Metric

### Imperial



Ball bearing ISO

6004; 6204; 6304;  
6404; 6804; 6904;  
16004; 61804;  
61904

6004; 6204; 6304;  
6404; 6804; 6904;  
16004; 61804;  
61904



Inner diameter of ball bearing

18 - 23 mm

3/4 - 7/8 inch



Effective depth

50 mm

2 inch



Length of internal extractor

90 mm

3 1/2 inch



Number of segments

3

3



Spanner size of the internal extractor

22 mm



Weight

0.21 kg



has to be accomplished with

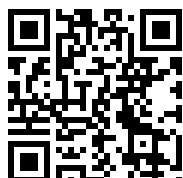

**Slide hammer device**

22-0

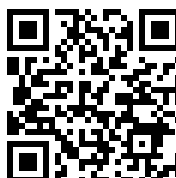

**Slide hammer device**

22-0-1



**Counterstay**

22-1



**Counterstay**

22-2



## Goes with

| <b>Art. No.</b> | <b>Product name</b> |
|-----------------|---------------------|
| 22-1            | Counterstay         |
| 22-2            | Counterstay         |

## Part of

| <b>Art. No.</b> | <b>Product name</b>   |
|-----------------|---|
| 27-A            | Universal puller set  |
| K-22-C-E        | Ball bearing extracting set with counterstay and slide hammer |
| K-22-B-E        | Ball bearing extracting set with counterstay and slide hammer |
| WT-017          | Puller product range - interior pulling - BASIC               |

## Spare part of

| <b>Art. No.</b> | <b>Product name</b>  |
|-----------------|----------------------|
| 27-A            | Universal puller set |

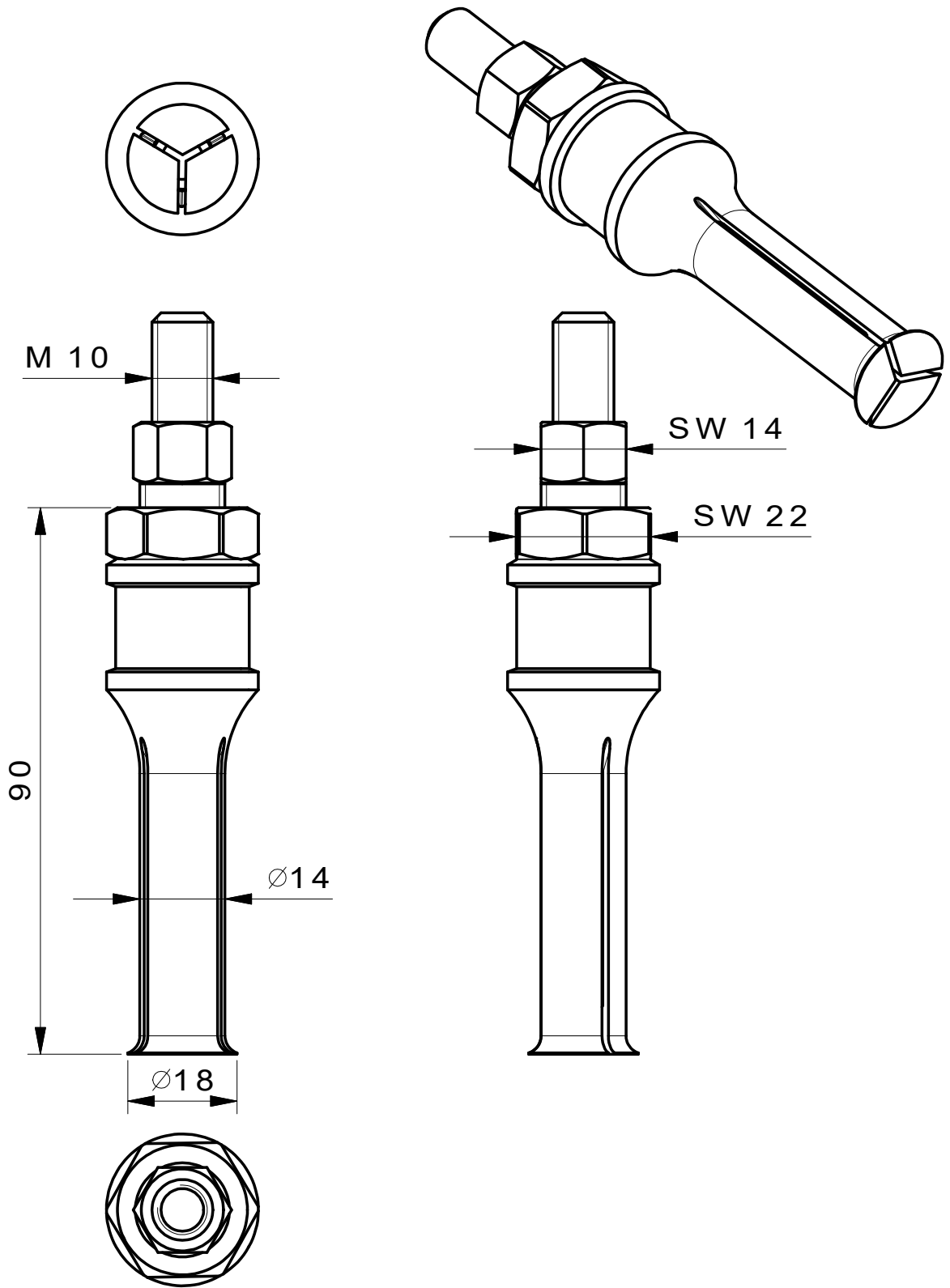

|  |   |                                 |   |  |
|--|---|---------------------------------|---|--|
|  <p><b>Kleinbongartz &amp; Kaiser oHG</b><br/>Werkzeugfabrik<br/>Hilden - Germany</p> | Dokumentname:<br>21-3-E_Segmentinnenauszieher |                                 | Toleranz:<br>DIN ISO 2768-m   |  |
|  | Dokumentbeschreibung:<br>Baugruppe            |                                 | Material:<br>Hochfester extra zäher Vergütungsstahl/<br>High tensile strength and toughness steel |  |
|  | Erstellt / Geprüft von:<br>Schultes           | Erstellungsdatum:<br>21/09/2015 | Maßstab:<br>1:1   |  |
| Teilbeschreibung:<br>Segment-Innenauszieher/ Internal extractor with segmented grasp edge  |   |                                 | Wärmebehandlung / Härte:<br>vergüteter Stahl/ tempered steel                                      |  |
|  |   |                                 | Oberflächenbehandlung:  |  |
| Artikelnummer / ZNR.:<br>21-3-E  | Dokumentversion:<br>-                         |                                 | Schutzvermerk<br>ISO 16016<br>beachten  |  |