



Nome do produto

Extratores internos com extremidades de aderência segmentadas

Para extrair rolamentos planos sobrepostos, anéis exteriores de rolamentos e buchas.

Artigo Nº 21-3-E

Série 21-E

EAN 4021176931109



Características

Métrico

Polegada



Rolamento de esferas ISO

6004; 6204; 6304;
6404; 6804; 6904;
16004; 61804;
61904

6004; 6204; 6304;
6404; 6804; 6904;
16004; 61804;
61904



Diâmetro interno do rolamento

18 - 23 mm

3/4 - 7/8 inch



Profundidade de utilização

50 mm

2 inch



Comprimento do extrator interno

90 mm

3 1/2 inch



Número de segmentos

3

3



Amplitude da chave do extrator interior

22 mm



Peso

0.21 kg



ainda necessita de

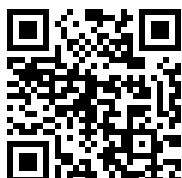

**Equipamento de martelo
deslizante**

22-0



**Equipamento de martelo
deslizante**

22-0-1

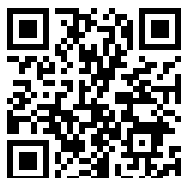

Suportes

22-1

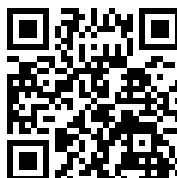

Suportes

22-2



é necessitado por

Artigo Nº	Nome do produto
22-1	Suportes
22-2	Suportes

Faz parte de

Artigo Nº	Nome do produto
27-A	Conjunto de extrator universal
K-22-C-E	Conjunto de extrator de rolamentos com suportes e martelo deslizante
K-22-B-E	Conjunto de extrator de rolamentos com suportes e martelo deslizante
WT-017	Gama de extratores - Extração interna - BASIC

é uma peça de substituição de

Artigo Nº	Nome do produto
27-A	Conjunto de extrator universal

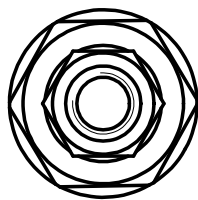
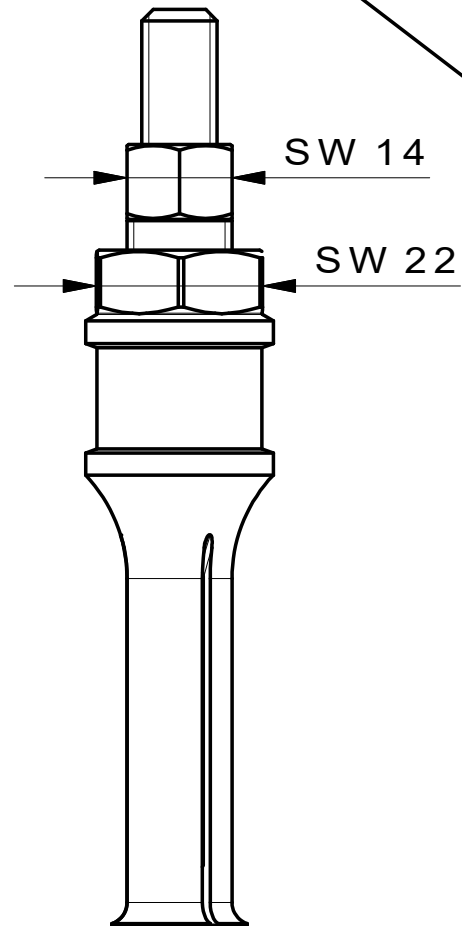
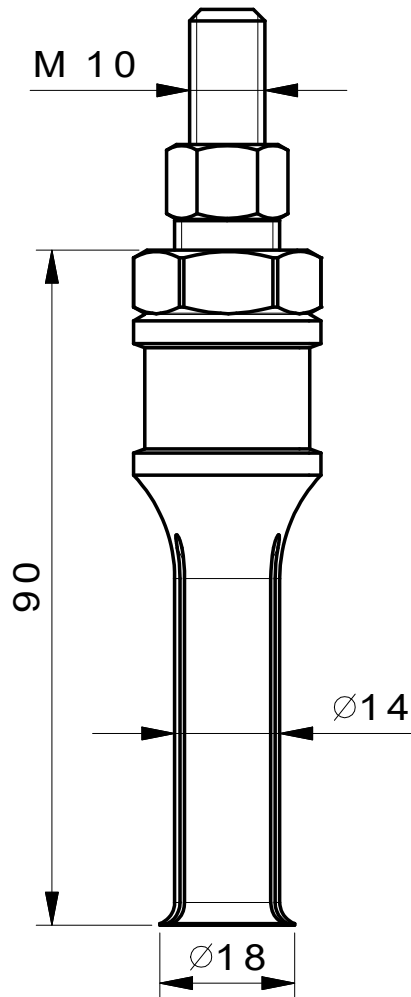
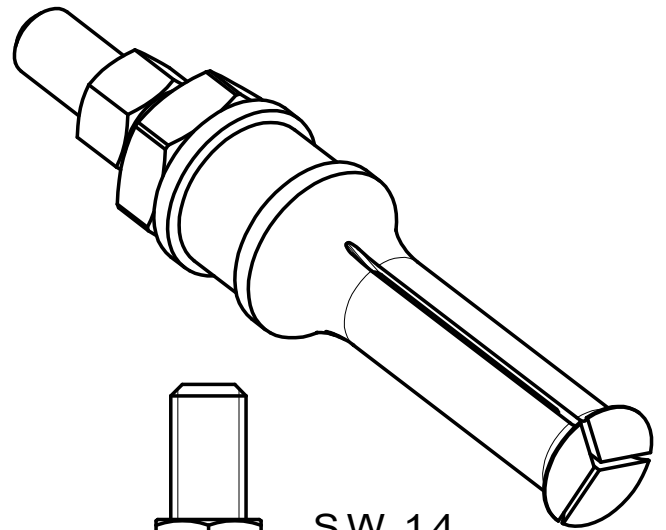
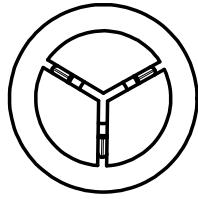

**Kleinbongartz
& Kaiser
oHG**
Werkzeugfabrik
Hilden - Germany

Dokumentname:
21-3-E_Segmentinnenauszieher

Toleranz:
DIN ISO 2768-m

Dokumentbeschreibung:
Baugruppe

Material:
Hochfester extra zäher Vergütungsstahl/
High tensile strength and toughness steel

Erstellt / Geprüft von:
Schultes

Erstellungsdatum:
21/09/2015

Maßstab:
1:1

Teilbeschreibung:

Segment-Innenauszieher/ Internal extractor with segmented grasp edge

Wärmebehandlung / Härte:
vergüteter Stahl/ tempered steel

Oberflächenbehandlung:

Artikelnummer / ZNR.:
21-3-E

Dokumentversion:
-

Schutzvermerk
ISO 16016
beachten