



产品名称

## 内取出器带分段握取楔

用于提取轴承，轴承外圈和相互平叠的套管。

编号 21-4-E

系列 21-E

EAN 4021176909191



### 技术规格

公制

英制



球轴ISO

6005; 6205; 6305;	6005; 6205; 6305;
6405; 6805; 6905;	6405; 6805; 6905;
16005; 61805;	16005; 61805;
61905; 6006;	61905; 6006;
6206; 6306; 6406;	6206; 6306; 6406;
16006; 61806;	16006; 61806;
61906	61906



球轴内径

24 - 34 mm

7/8 - 1 3/8 inch



有效深度

58 mm

2 1/4 inch



内提取器长度

98 mm

3 7/8 inch



部件数

3

3



内提取器的扳手宽度

22 mm



重量

0.25 kg



## 完整



滑锤设备  
22-0

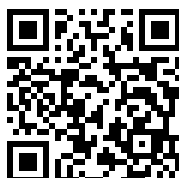

滑锤设备  
22-0-1

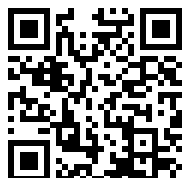

反向支撑拉马  
22-1

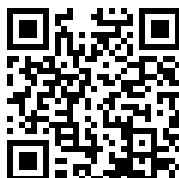

反向支撑拉马  
22-2



## 伴随

编号	产品名称
22-1	反向支撑拉马
22-2	反向支撑拉马

## 部分

编号	产品名称
27-A	通用拉马套装
K-22-C-E	球轴提取套装带反向支撑和滑锤
K-22-B-E	球轴提取套装带反向支撑和滑锤
WT-017	拉马产品系列 - 内拉- 基础

## 配件

编号	产品名称
27-A	通用拉马套装

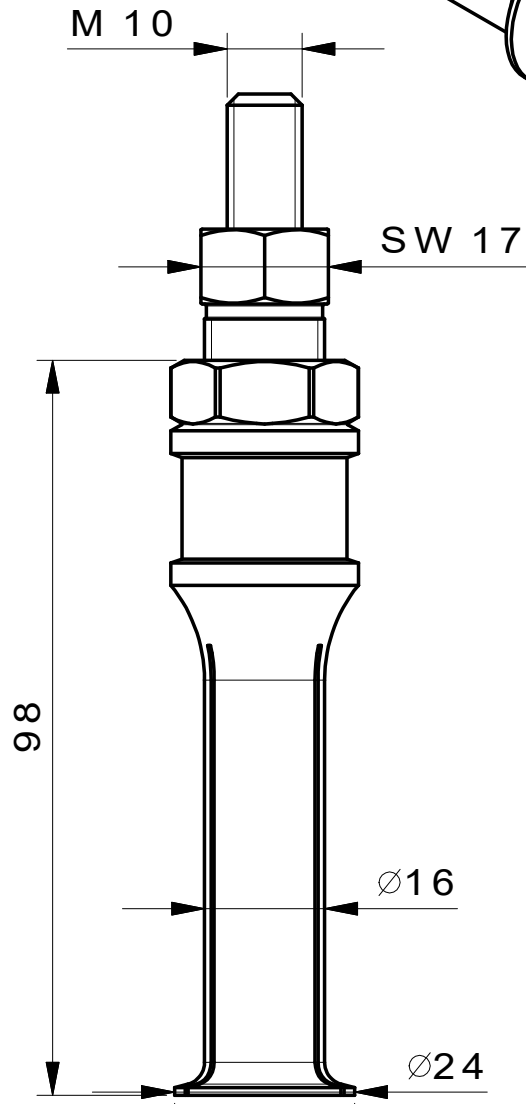
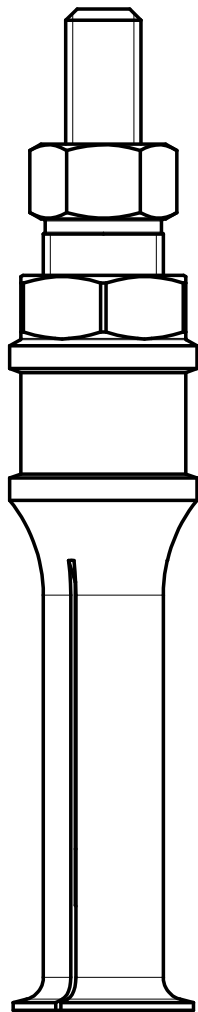
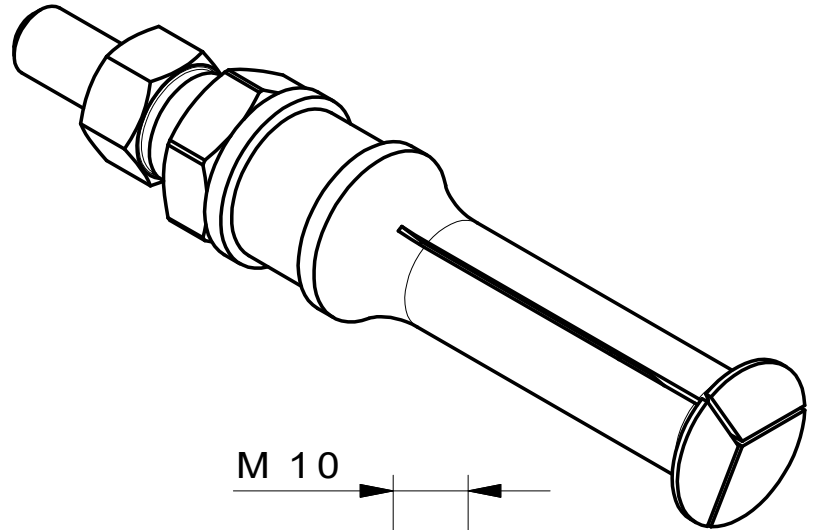
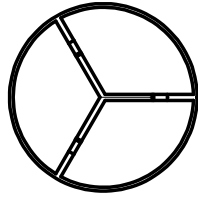

**Kleinbongartz  
& Kaiser  
oHG**  
Werkzeugfabrik  
Hilden - Germany

Dokumentname:  
21-4-E\_Segment-Innenauszieher

Toleranz:  
DIN ISO 2768-m

Dokumentbeschreibung:  
Baugruppe

Material:  
Hochfester extra zäher Vergütungsstahl/  
High tensile strength and toughness steel

Erstellt von:  
Breidenbach

Erstellungsdatum:  
09/02/2017

Maßstab:  
1:1

Teilbeschreibung:

Segment-Innenauszieher/ Internal extractor with segmented grasp edge

Wärmebehandlung / Härte:  
vergüteter Stahl/ tempered steel

Oberflächenbehandlung:

Artikelnummer / ZNR.:  
21-4-E

Dokumentversion:  
-

Schutzvermerk  
ISO 16016  
beachten