



Nome del prodotto

Estrattore interno con angoli di presa segmentati

Per l'estrazione di cuscinetti, anelli di cuscinetti e bocche che giacciono in piano.

Num. art. 21-5-E

Serie 21-E

EAN 4021176924071

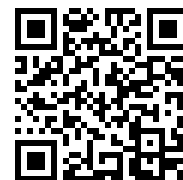

Attributo tecnico

Metrico

Imperiale



Cuscinetto a sfera ISO

6007; 6207; 6307;	6007; 6207; 6307;
6407; 16007; 61807;	6407; 16007; 61807;
61907; 6008; 6208;	61907; 6008; 6208;
6308; 6408; 16008;	6308; 6408; 16008;
61808; 61908; 6009;	61808; 61908; 6009;
6209; 6309; 6409;	6209; 6309; 6409;
16009; 61809;	16009; 61809;
61909	61909



Diametro interno del cuscinetto a sfere

34 - 48 mm

1 3/8 - 1 7/8 inch



Profondità di inserimento

65 mm

2 5/8 inch



Lunghezza estrattore interno

110 mm

4 3/8 inch



Numero di segmenti

4

4



Larghezza della chiave dell'estrattore interno

24 mm



Peso

0.215 kg



esige anche



Dispositivi battenti

22-0-1

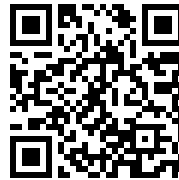

Controsupporti

22-2



Viene utilizzato da

Num. art.	Nome del prodotto
22-2	Controsupporti

é parte di

Num. art.	Nome del prodotto
27-A	Set di estrattori universali
WT-017	Assortimento estrattori - Estrazione interna - BASIC

é pezzo di ricambio di

Num. art.	Nome del prodotto
27-A	Set di estrattori universali

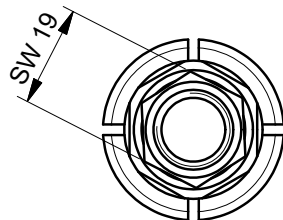
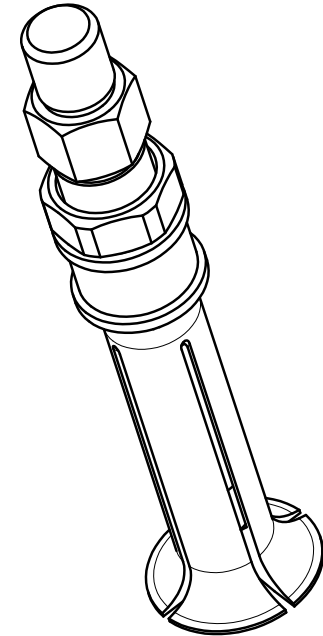
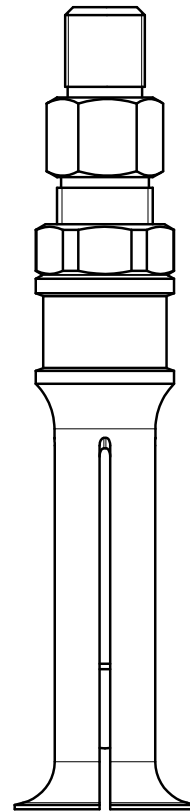
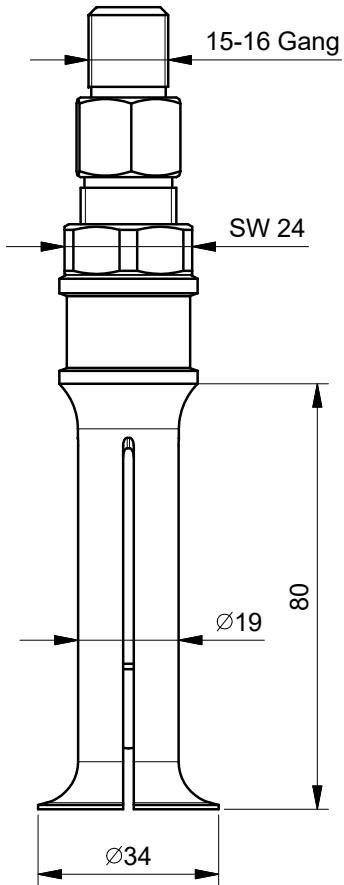
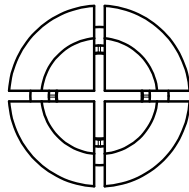

 Kleinbongartz & Kaiser oHG Werkzeugfabrik Hilden - Germany	Dokumentname: 21-5-E_Segment-Innenauszieher		Toleranz: DIN ISO 2768-m
	Dokumentbeschreibung: Baugruppe		Material: Hochfester extra zäher Vergütungsstahl/ High tensile strength and toughness steel
	Erstellt / Geprüft von: Schultes	Erstellungsdatum: 21/09/2015	Maßstab: 1:1
Teilbeschreibung: Segment-Innenauszieher/ Internal extractor with segmented grasp edge			Wärmebehandlung / Härte: vergüteter Stahl/ tempered steel
Oberflächenbehandlung:			Schutzvermerk ISO 16016 beachten
Artikelnummer / ZNR.: 21-5-E	Dokumentversion: -		