



产品名称

内取出器带分段握取楔

用于提取轴承，轴承外圈和相互平叠的套管。

编号 21-7-E

系列 21-E

EAN 4021176924095



技术规格

公制

英制



球轴ISO

| | |
|------------------------------------|------------------------------------|
| 6013; 6213; 6313; 16013; 61913; | 6013; 6213; 6313; 16013; 61913; |
| 6014; 6214; 6314; 16014; 6015; | 6014; 6214; 6314; 16014; 6015; |
| 6215; 6315; 16015 | 6215; 6315; 16015 |



球轴内径

63 - 78 mm 2 1/2 - 3 1/16 inch



有效深度

80 mm 3 3/16 inch



内提取器长度

120 mm 4 3/4 inch



部件数

6 6



内提取器的扳手宽度

32 mm



重量

0.86 kg



完整

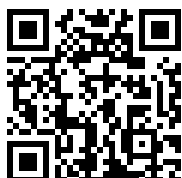

滑锤设备
22-0-1

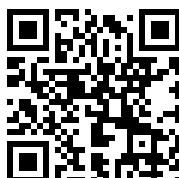

反向支撑拉马
22-2



伴随

编号

产品名称

22-2

反向支撑拉马

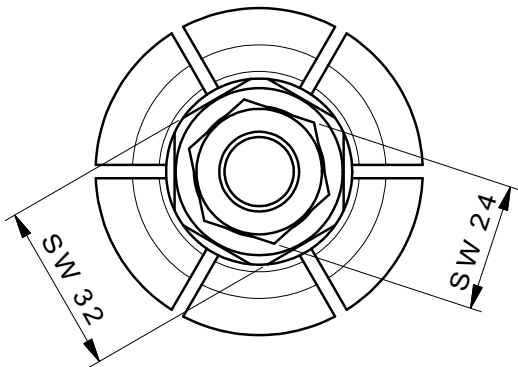
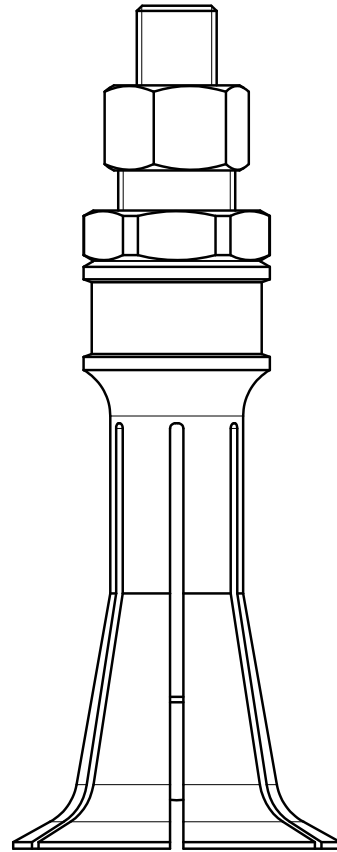
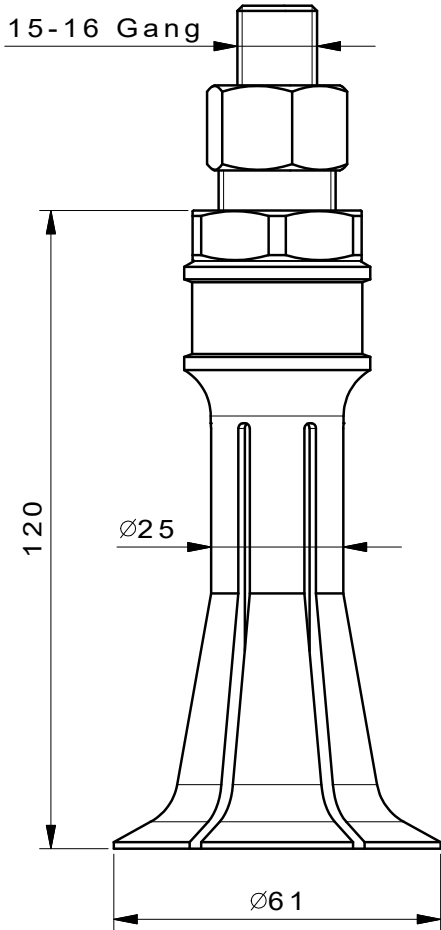
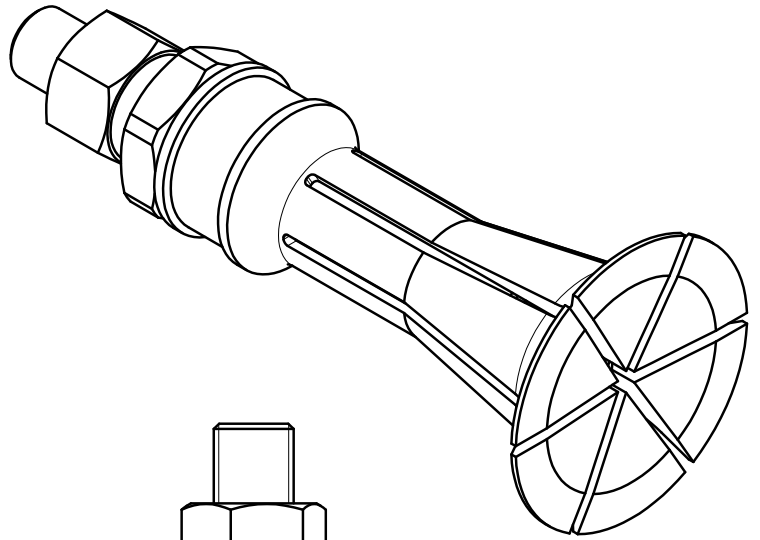
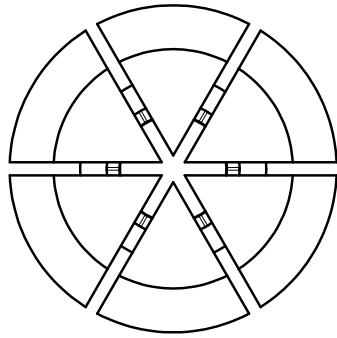

| | | | |
|---|--|--|---|
|  Kleinbongartz & Kaiser oHG Werkzeugfabrik Hilden - Germany | Dokumentname: 21-7-E_Segment-Innenauszieher | | Toleranz: DIN ISO 2768-m |
| | Dokumentbeschreibung: Baugruppe | | Material: Hochfester extra zäher Vergütungsstahl/ High tensile strength and toughness steel |
| | Erstellt von: Schultes | Erstellungsdatum: 18/04/2016 | Maßstab: 1:1 |
| Teilbeschreibung: Segment-Innenauszieher/ Internal extractor with segmented grasp edge | | Wärmebehandlung / Härte: vergüteter Stahl/ tempered steel | |
| | | Oberflächenbehandlung: | |
| Artikelnummer / ZNR.: 21-7-E | Dokumentversion: - | Schutzvermerk ISO 16016 beachten | |