



Nome del prodotto

## Estrattore interno a 2 strati

Per l'estrazione di cuscinetti interni, anelli di cuscinetti e bocche.

Num. art. 21-8

Serie 21

EAN 4021176011726

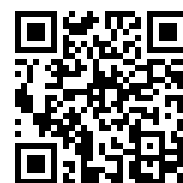

### Attributo tecnico

### Metrico

### Imperiale



Cuscinetto a sfera ISO

6012; 6212; 6312;	6012; 6212; 6312;
6412; 16012; 61812;	6412; 16012; 61812;
61912; 6013; 6213;	61912; 6013; 6213;
6313; 16013; 61913;	6313; 16013; 61913;
6014; 6214; 6314;	6014; 6214; 6314;
16014	16014



Diametro interno del cuscinetto a sfere

56 - 70 mm

2 1/4 - 2 3/4 inch



Profondità di inserimento

85 mm

3 3/8 inch



Lunghezza estrattore interno

133 mm

5 1/4 inch



Numero di segmenti

2

2



Peso

1.43 kg



esige anche

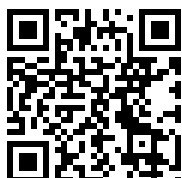

**Dispositivi battenti**

22-0-1

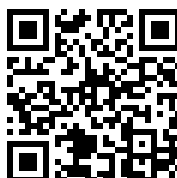

**Controsupporti**

22-2

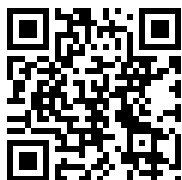

**Controsupporti**

22-3



## Viene utilizzato da

<b>Num. art.</b>	<b>Nome del prodotto</b>
22-2	Controsupporti
22-3	Controsupporti

## é parte di

<b>Num. art.</b>	<b>Nome del prodotto</b>
24-B	Set di estrattori per cuscinetti a sfere
25-B	Set di estrattori per cuscinetti a sfere
28-D	Set di estrattori a battenti e controsupporti per l'estrazione di cuscinetti a sfera e spine cilindriche
WT-017	Assortimento estrattori - Estrazione interna - BASIC
WT-018	Assortimento estrattori - Estrazione interna - TOP
K-22-B	Estrattore per cuscinetti a sfere in Set con controsupporti e estrattore a battente



é pezzo di ricambio di

<b>Num. art.</b>	<b>Nome del prodotto</b>
24-B	Set di estrattori per cuscinetti a sfere
25-B	Set di estrattori per cuscinetti a sfere

é incluso anche in

<b>Num. art.</b>	<b>Nome del prodotto</b>
WT-018	Assortimento estrattori - Estrazione interna - TOP

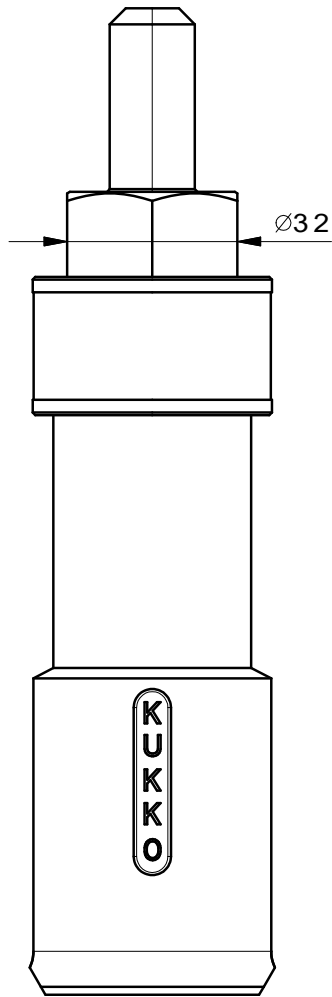
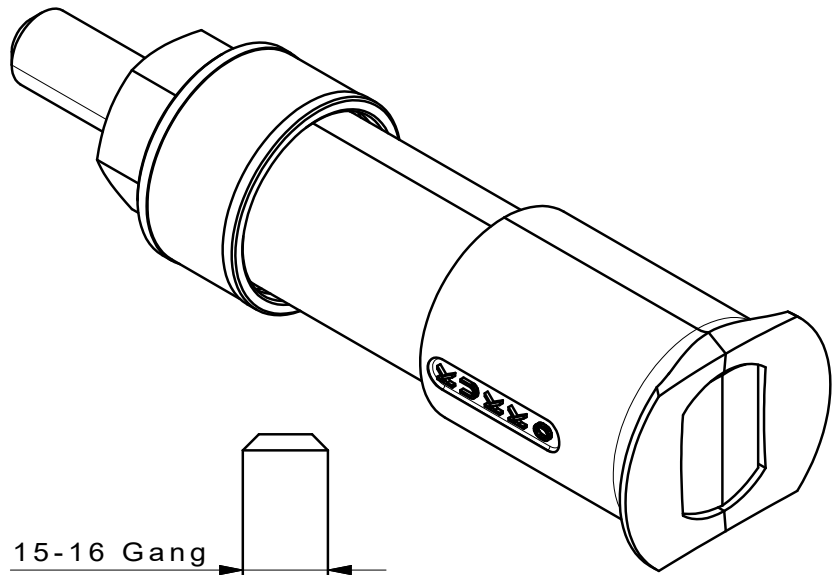
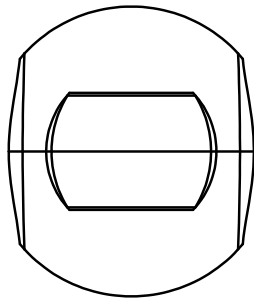

15-16 Gang

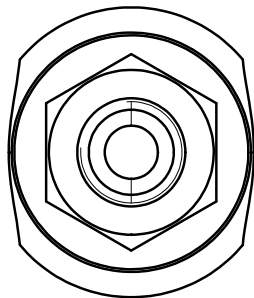
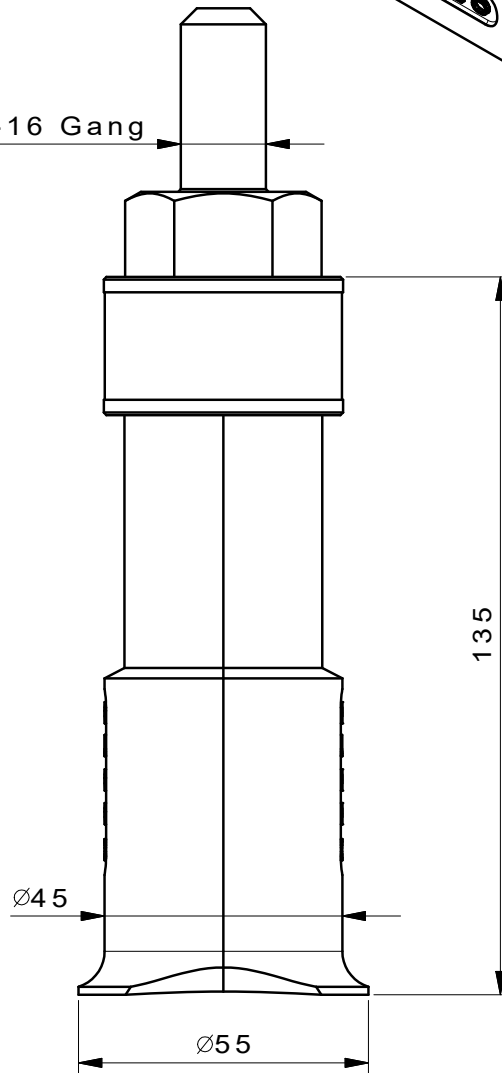

 <b>Kleinbongartz &amp; Kaiser oHG</b> Werkzeugfabrik Hilden - Germany	Dokumentname: 21-8 Innenauszieher		Toleranz: DIN ISO 2768-m
	Dokumentbeschreibung: ZSB		Material: Hochfester extra zäher Vergütungsstahl/ High tensile strength and toughness steel
Teilbeschreibung: Innenauszieher/ Internal extractor	Erstellt / Geprüft von: Schultes	Erstellungsdatum: 05/06/2015	Maßstab: 1:1
		Wärmebehandlung / Härte: vergüteter Stahl/ tempered steel	
		Oberflächenbehandlung:	
Artikelnummer / ZNR.: 21-8	Dokumentversion: -	Schutzvermerk ISO 16016 beachten	